

REVISIONS				
P	LTR	DESCRIPTION	DATE	DWN APVD
Y		REVISED PER ECO-21-002071	08SEP2021	AK SZ

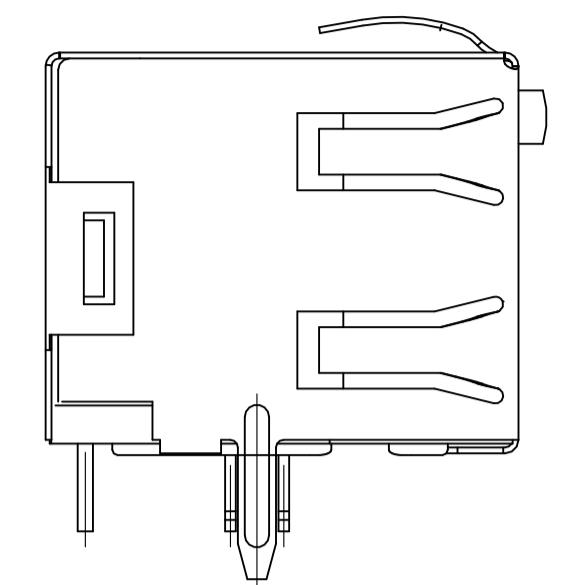

VIEW OF 3-406549-8, 4-406549-8;

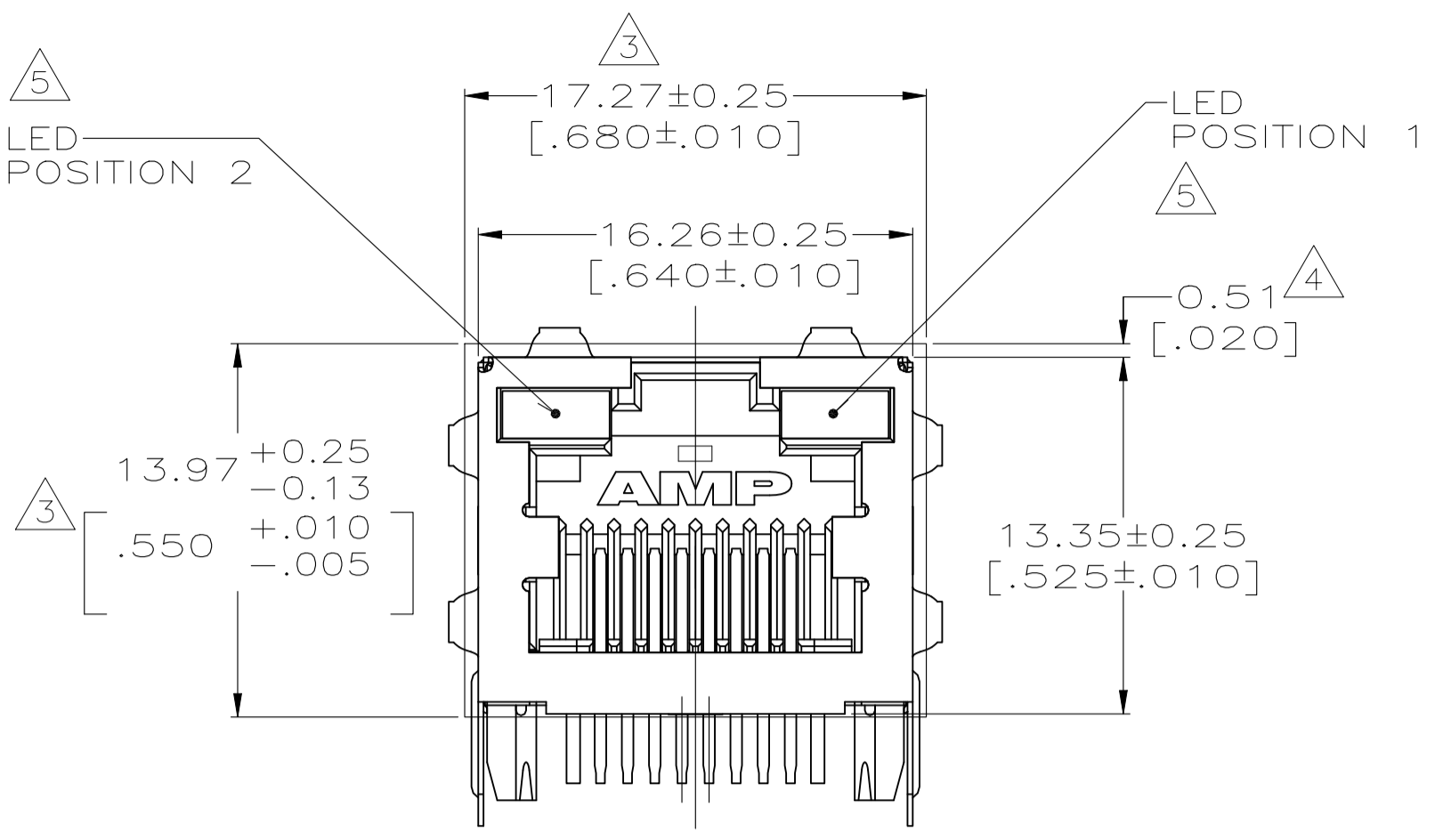
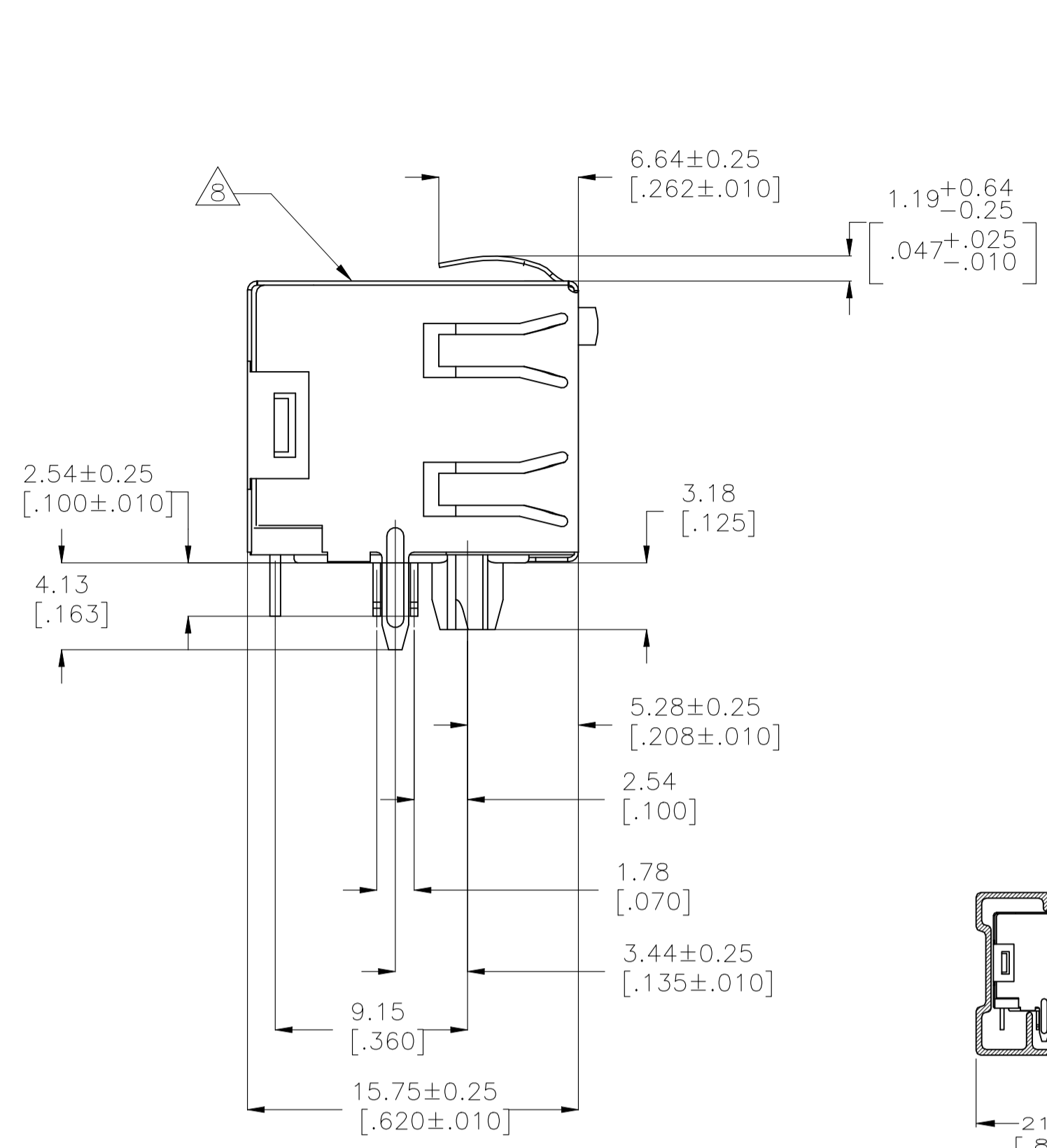
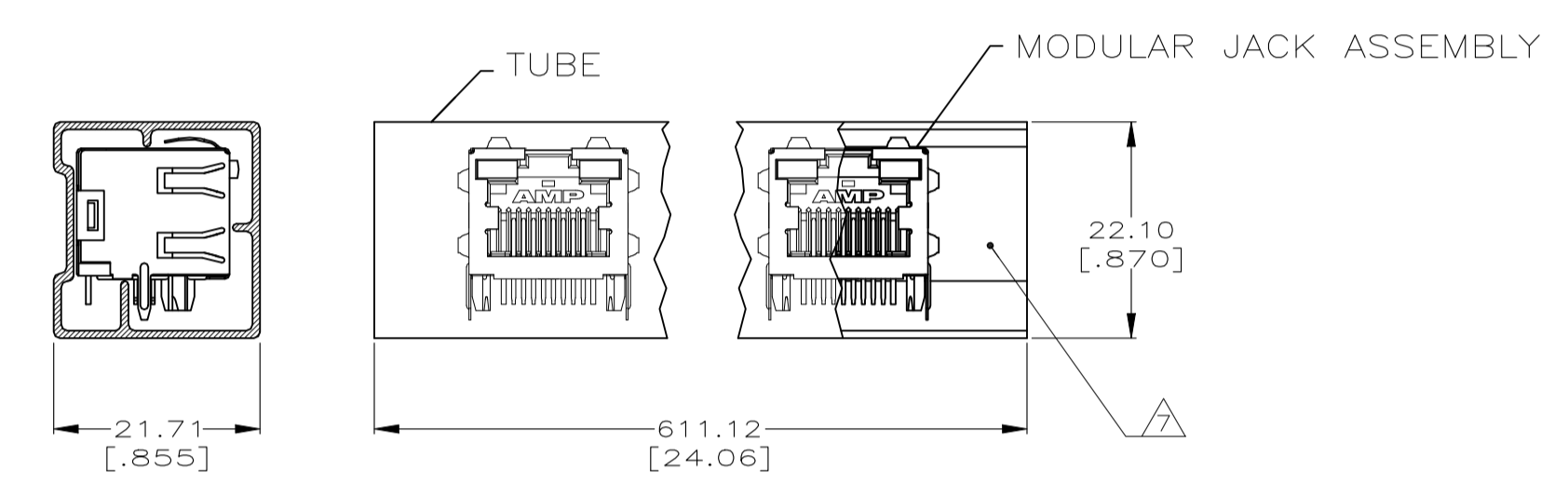

DETAIL A
TUBE PACKAGE
SCALE 2:1

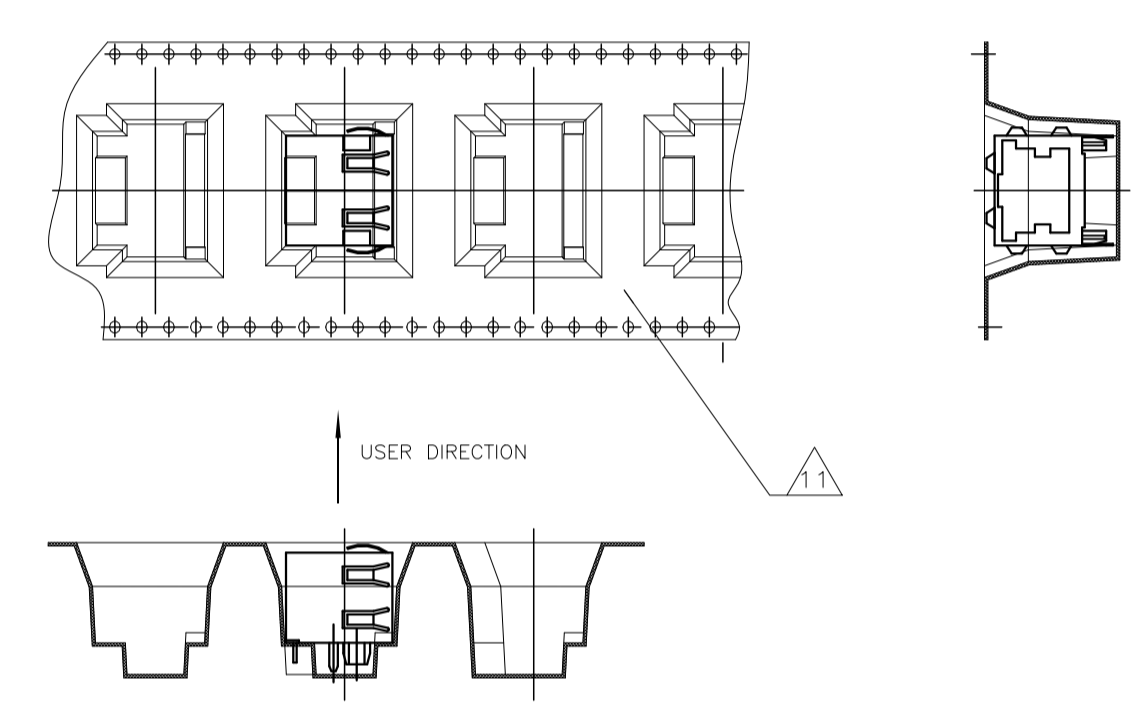

DETAIL B
TAPE REEL PACKAGE
SCALE 2:1

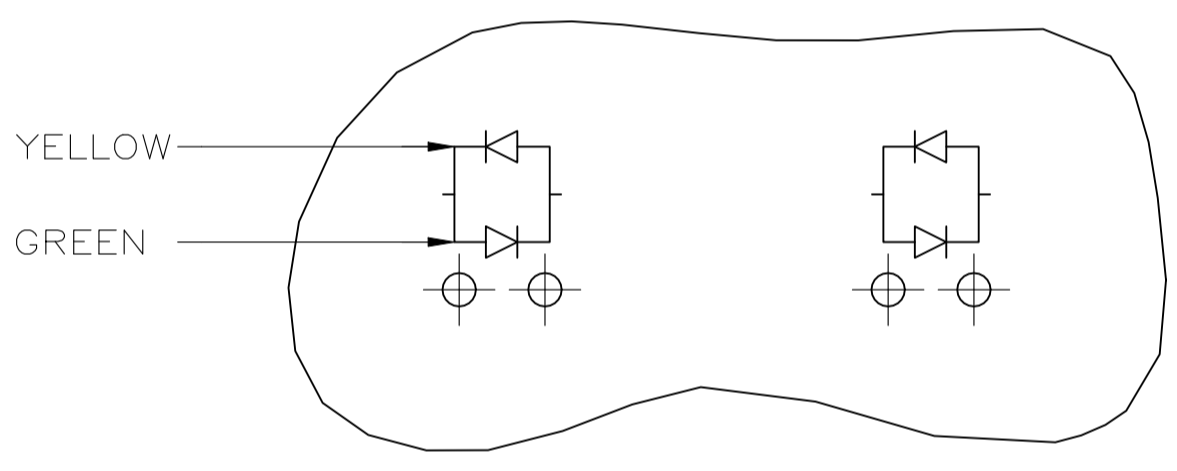

LED CURRENT DIAGRAM
406549-8, 2-406549-8

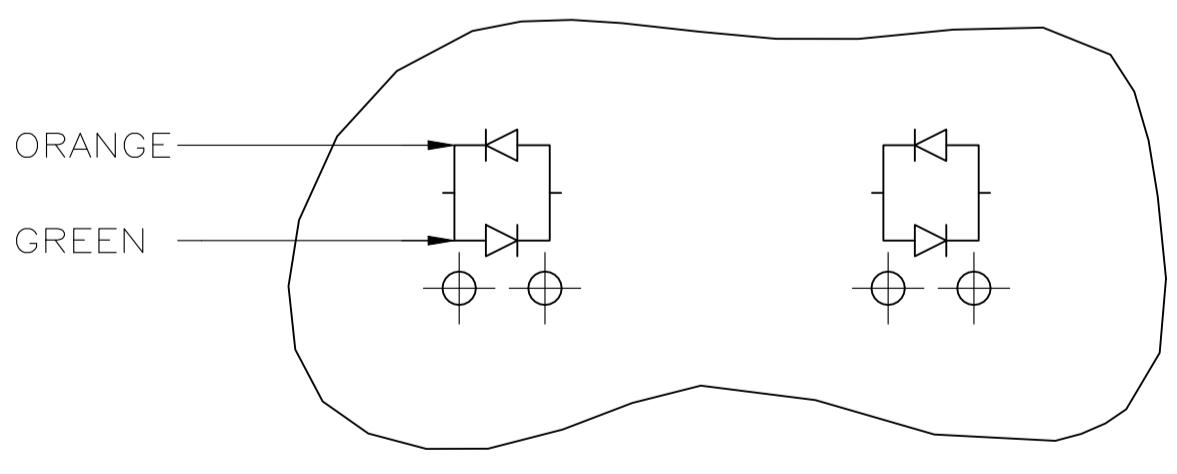

LED CURRENT DIAGRAM
2-406549-7 ONLY

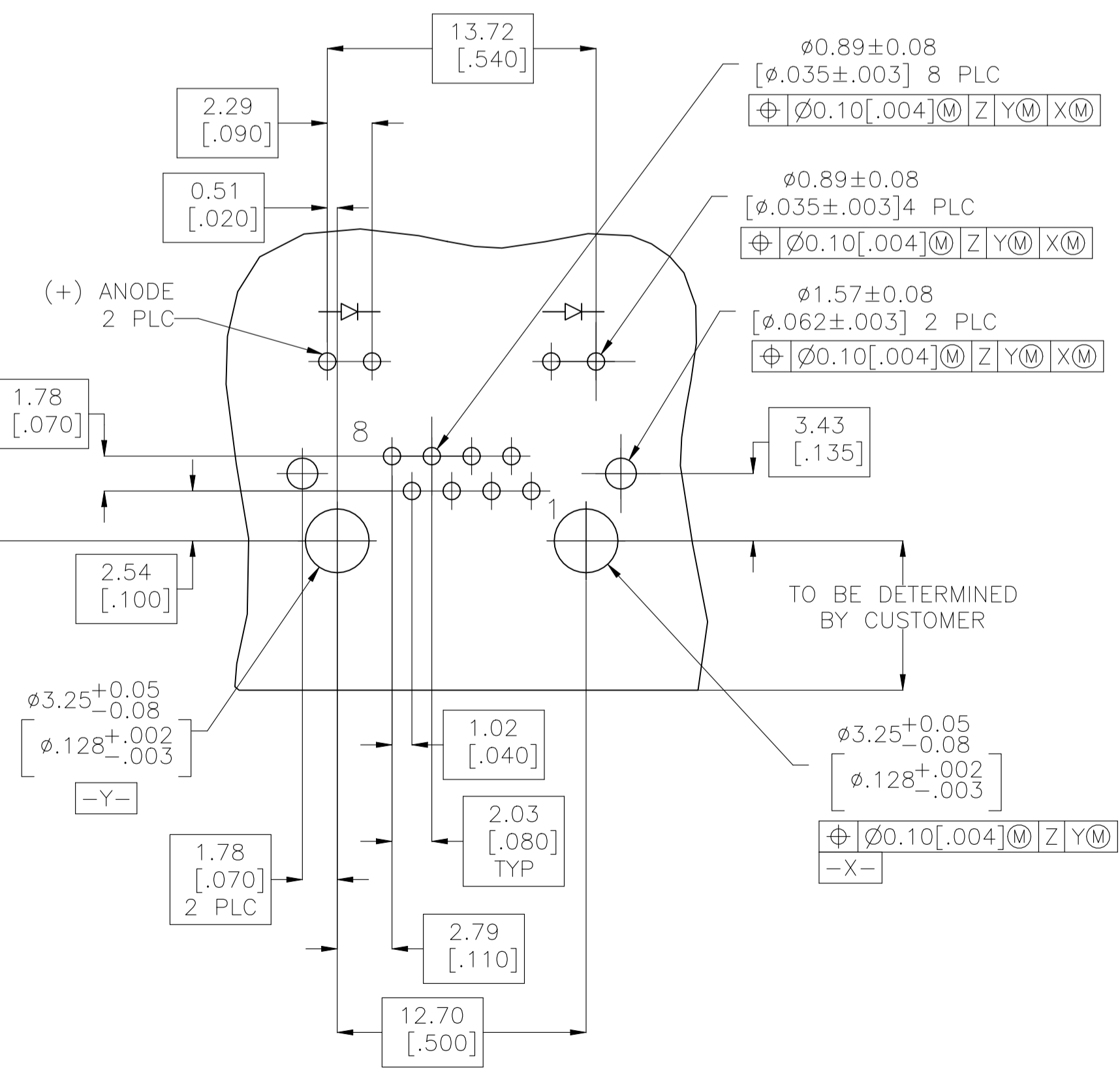

RECOMMENDED PRINTED CIRCUIT BOARD LAYOUT
(COMPONENT SIDE)

- 1 MATERIAL: HOUSING - HIGH TEMPERATURE THERMOPLASTIC, BLACK, UL94V-0. TERMINALS - 0.36[.014] THICK PHOS BRONZE PLATED WITH 3.81µm[.000150] MINIMUM THICK (SEE P/N TABLE) IN SOLDER AREA. 1.27µm[.000050] MINIMUM GOLD IN LOCALIZED PLATE AREA. ENTIRE TERMINAL PLATED WITH 1.27µm[.000050] MINIMUM THICK NICKEL. SHIELD - 0.196[.0077] THICK COPPER ZINC ALLOY PREPLATED WITH 1.27µm[.000050] MINIMUM SATIN NICKEL WITH 2.03µm[.000080] MINIMUM TIN POST DIPPED ON PCB GROUND TABS. LIGHT EMITTING DIODE (LED) - DIFFUSED EPOXY LENS, 0.51 x 0.51[.020 x .020] CARBON STEEL WIREFRAME LEADS PLATED WITH 8.89µm[.000350] TIN/COPPER OVER 2.03[.000080] SILVER OVER 1.02µm[.000040] NICKEL UNDERPLATE OVER 1.02µm[.000040] COPPER UNDERPLATE.
- 2. JACK CAVITY CONFORMS TO FCC RULES AND REGULATIONS PART 68, SUBPART F.
- 3 SUGGESTED PANEL OPENING DIMENSIONS.
- 4 SUGGESTED CLEARANCE BETWEEN TOP OF CONNECTOR AND TOP PANEL OPENING.
- 5 SEE TABLE FOR COLOR OF LEDS AND NUMBER REQUIRED.
- 6. THIS MODULAR JACK WITH INTEGRATED LED IS NOT IR REFLOW SOLDERING PROCESS COMPATIBLE.
- 7 PACKAGED 30 PIECES PER TUBE, SEE DETAIL "A".
- 8 MANUFACTURING DATE CODE: LOCATED APPROX. AS SHOWN. FIRST 2 DIGITS = LAST 2 DIGITS OF YEAR. NEXT 2 DIGITS = MANUFACTURING WORK WEEK. LAST DIGIT = DAY OF WEEK WITH SUNDAY = 1.
- 9 THE PART IS PRELIMINARY.
- 10 OBSOLETE PARTS: OBSOLETE CIS STREAMLINING PER D.RENAUD/D.SINISI
- 11 TAPE REEL PACKAGE ,SEE DETAIL B.
- 12 WITHOUT PLASTIC POST, SEE VIEW OF 3-406549-8, AND 4-406549-8;
- 13 REFLOW SOLDER PROCESS COMPATIBLE 245 DEGREE CELSIUS, WITHIN 10 SECONDS.

13	MATTE TIN	TAPE REEL	YELLOW/GREEN	YELLOW/GREEN	4-406549-8
OBSOLETE	MATTE TIN	TAPE REEL	YELLOW/GREEN	YELLOW/GREEN	3-406549-8
OBSOLETE	MATTE TIN	TRAY	-	GREEN/RED	3-406549-3
OBSOLETE	MATTE TIN	TRAY	RED	GREEN	3-406549-2
OBSOLETE	MATTE TIN	TUBE	YELLOW	GREEN	3-406549-1
OBSOLETE	MATTE TIN	TRAY	ORANGE/GREEN	GREEN	3-406549-0
OBSOLETE	MATTE TIN	TRAY	ORANGE/GREEN	YELLOW	2-406549-9
	MATTE TIN	TRAY	YELLOW/GREEN	YELLOW/GREEN	2-406549-8
	MATTE TIN	TRAY	ORANGE/GREEN	ORANGE/GREEN	2-406549-7
OBSOLETE	MATTE TIN	TRAY	YELLOW	YELLOW	2-406549-6
	MATTE TIN	TRAY	GREEN	GREEN	2-406549-5
	MATTE TIN	TRAY	GREEN	YELLOW	2-406549-4
OBSOLETE	MATTE TIN	TRAY	YELLOW	-	2-406549-3
	MATTE TIN	TRAY	-	GREEN	2-406549-2
	MATTE TIN	TRAY	YELLOW	GREEN	2-406549-1
OBSOLETE	TIN-LEAD	TRAY	YELLOW/GREEN	YELLOW/GREEN	406549-8
OBSOLETE	TIN-LEAD	TRAY	YELLOW	YELLOW	406549-6
OBSOLETE	TIN-LEAD	TRAY	GREEN	GREEN	406549-5
OBSOLETE	TIN-LEAD	TRAY	GREEN	YELLOW	406549-4
OBSOLETE	TIN-LEAD	TRAY	YELLOW	-	406549-3
	TIN-LEAD	TRAY	-	GREEN	406549-2
OBSOLETE	TIN-LEAD	TRAY	YELLOW	GREEN	406549-1
	TERMINAL LEAD PLATING	PACKAGING	POSITION 2	POSITION 1	PART NUMBER
			INDICATOR COLOR		

THIS DRAWING IS A CONTROLLED DOCUMENT. DWN G. GARRETT 17-SEP-97
CHK G. GARRETT 17-SEP-97

TE Connectivity

INVERTED MODULAR JACK ASSEMBLY, 1X1, SHIELDED, PANEL GROUND, LED

108-1163-4

114-2154

A1 00779 406549

SCALE 4:1 SHEET 1 OF 1 REV Y