

# PHOTONIC DETECTORS INC.

## Silicon Photodiode, Filter Combination Photovoltaic 500 nm (blue color) Type PDV-V405

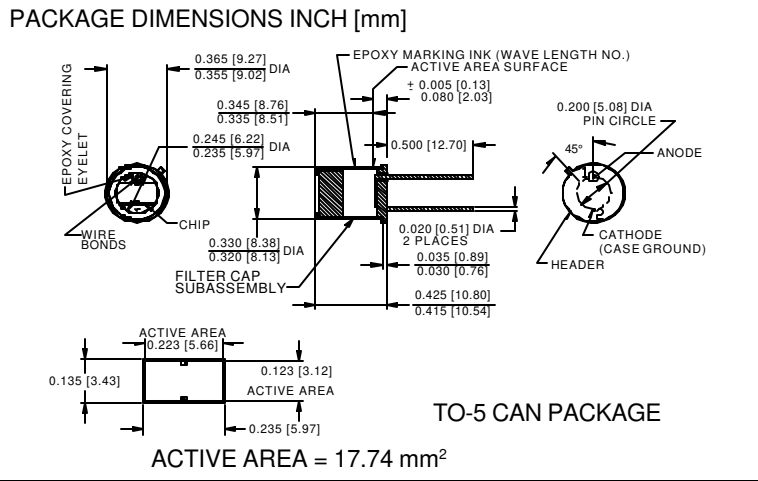

### FEATURES

- 500 nm CWL
- 70 nm FWHM
- Low noise

**DESCRIPTION:** The PDV-V405 is a silicon, PIN planar diffused, photodiode with a blue color 500 nm +/- 2 nm CWL wide band interference filter and a wide 70 nm halfbandwidth. Ideal for color film processing, color meters, and other photometry and radiometry measurement applications.

### APPLICATIONS

- Blue color matching
- Color meters
- Film processing

### ABSOLUTE MAXIMUM RATING (TA=25°C unless otherwise noted)

SYMBOL	PARAMETER	MIN	MAX	UNITS
V <sub>BR</sub>	Reverse Voltage		100	V
T <sub>STG</sub>	Storage Temperature	-20	+85	°C
T <sub>O</sub>	Operating Temperature Range	-15	+70	°C
T <sub>S</sub>	Soldering Temperature*		+240	°C
I <sub>L</sub>	Light Current		0.5	mA

\*1/16 inch from case for 3 secs max

### SPECTRAL RESPONSE

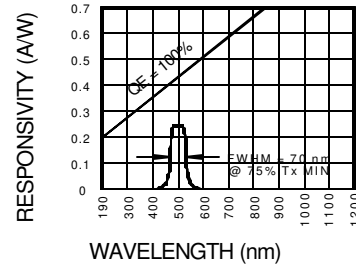

### ELECTRO-OPTICAL CHARACTERISTICS (TA=25°C unless otherwise noted)

SYMBOL	CHARACTERISTIC	TEST CONDITIONS	MIN	TYP	MAX	UNITS
I <sub>SC</sub>	Short Circuit Current***	H = 100 fc, 2850 K	150	200		μA
I <sub>D</sub>	Dark Current	H = 0, V <sub>R</sub> = 10 mV		10	50	pA
R <sub>SH</sub>	Shunt Resistance	H = 0, V <sub>R</sub> = 10 mV	.20	2		Ω
TC R <sub>SH</sub>	R <sub>SH</sub> Temp. Coefficient	H = 0, V <sub>R</sub> = 10 mV		-8		% / °C
C <sub>J</sub>	Junction Capacitance	H = 0, V <sub>R</sub> = 10 V**		1700		pF
CWL	Center Wavelength	(CWL, λ <sub>0</sub> ) +/- 2 nm		500		nm
HBW	Half Bandwidth	(FWHM)		70		nm
V <sub>BR</sub>	Breakdown Voltage	I = 10 μA	50	75		V
NEP	Noise Equivalent Power	V <sub>R</sub> = 10 mV @ Peak		9x10 <sup>-15</sup>		W/√Hz
tr	Response Time	RL = 1 KΩ V <sub>R</sub> = 10 V		1.0		μS

Information in this technical data sheet is believed to be correct and reliable. However, no responsibility is assumed for possible inaccuracies or omission. Specifications are subject to change without notice.\*\*f = 1 MHz, \*\*\*without filter

[FORM NO. 100-PDV-V405 REV A]