

# Argon Datasheet

The Argon has been deprecated. The recommended replacement is the Photon 2. See the [Photon 2 Datasheet](#) and [Photon 2 from Argon Migration Guide](#) for more information.



# Functional description

## OVERVIEW

---

The Argon is a powerful Wi-Fi enabled development board for Wi-Fi networks. It is based on the Nordic nRF52840 and has built-in battery charging circuitry so it's easy to connect a Li-Po and deploy your local network in minutes.

The Argon is great for connecting existing projects to the Particle Device Cloud over a Wi-Fi network.

## FEATURES

---

- Espressif ESP32-D0WD 2.4 GHz Wi-Fi coprocessor
- On-board 4MB flash for ESP32
- 802.11 b/g/n support
- 802.11 n (2.4 GHz), up to 150 Mbps
- Nordic Semiconductor nRF52840 SoC
- ARM Cortex-M4F 32-bit processor @ 64MHz
- 1MB flash, 256KB RAM
- Bluetooth 5: 2 Mbps, 1 Mbps, 500 Kbps, 125 Kbps
- Supports DSP instructions, HW accelerated Floating Point Unit (FPU) and encryption functions
- Up to +8 dBm TX power (down to -20 dBm in 4 dB steps)
- NFC-A tag
- On-board additional 4MB SPI flash
- 20 mixed signal GPIO (6 x Analog, 8 x PWM), UART, I2C, SPI
- Micro USB 2.0 full speed (12 Mbps)
- Integrated Li-Po charging and battery connector
- JTAG (SWD) Connector
- RGB status LED
- Reset and Mode buttons
- On-board PCB antenna
- U.FL connector for external antenna
- Meets the Adafruit Feather [specification](#) in dimensions and pinout
- FCC, CE and IC certified
- RoHS compliant (lead-free)

## DEVICE OS SUPPORT

---

It is recommended that you use the latest version in the 4.x LTS release line with the Argon.

While Argons can use an older version of Device OS:

- Device OS 3.x is a developer preview release and has reached its end-of-support date.
- The 2.x LTS release line is in the Extended Support and Maintenance (ESM) window and will stop being supported in 2024.
- Earlier versions of Device OS have reached their end-of-support dates.

For information on upgrading Device OS, see [Version information](#). For the latest version shipped from the factory, see [Manufacturing firmware versions](#) page. See also [Long Term Support \(LTS\) releases](#).

# Interfaces

## BLOCK DIAGRAM

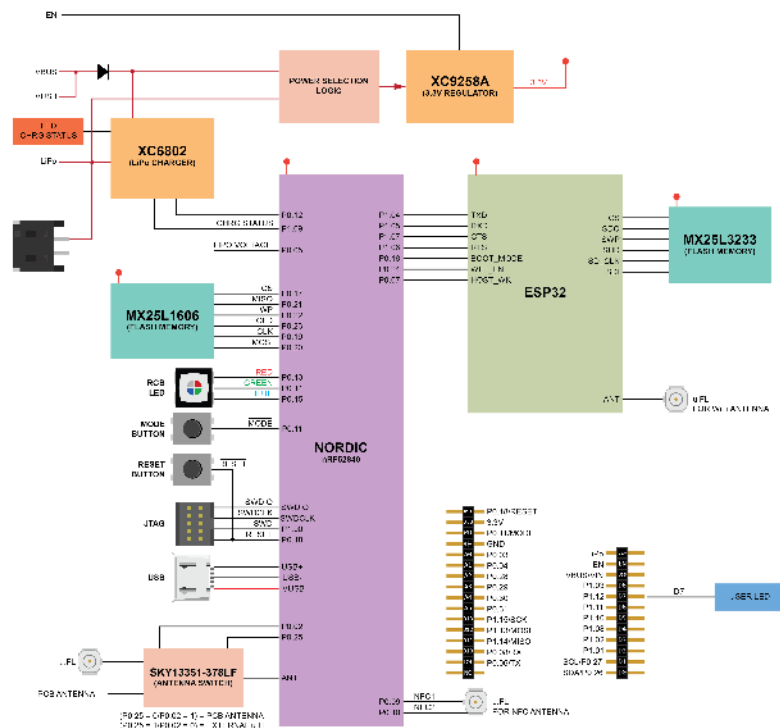

## POWER

### USB PORT

The USB port is the easiest way to power up the Argon. Please make sure that the USB port is able to provide at least 500mA. Power from the USB is regulated down to 3.3V by the on board Torex XC9258A step-down regulator.

### VUSB PIN

The pin is internally connected to the VBUS of the USB port. The nominal output should be around 4.5 to 5 VDC when the device is plugged into the USB port and 0 when not connected to a USB source. You can use this pin to power peripherals that operate at such voltages. Do not exceed the current rating of the USB port, which is nominally rated to 500mA. This pin is also protected with an internal fuse rated at 1000mA.

### LiPo

If you want to make your projects truly wireless, you can power the device with a single cell LiPo (3.7V). The Argon has an on board LiPo charger that will charge and power the device when USB source is plugged in or power the device from the LiPo alone in the absence of the USB.

**NOTE:** Please pay attention to the polarity of the LiPo connector. Not all LiPo batteries follow the same polarity convention!

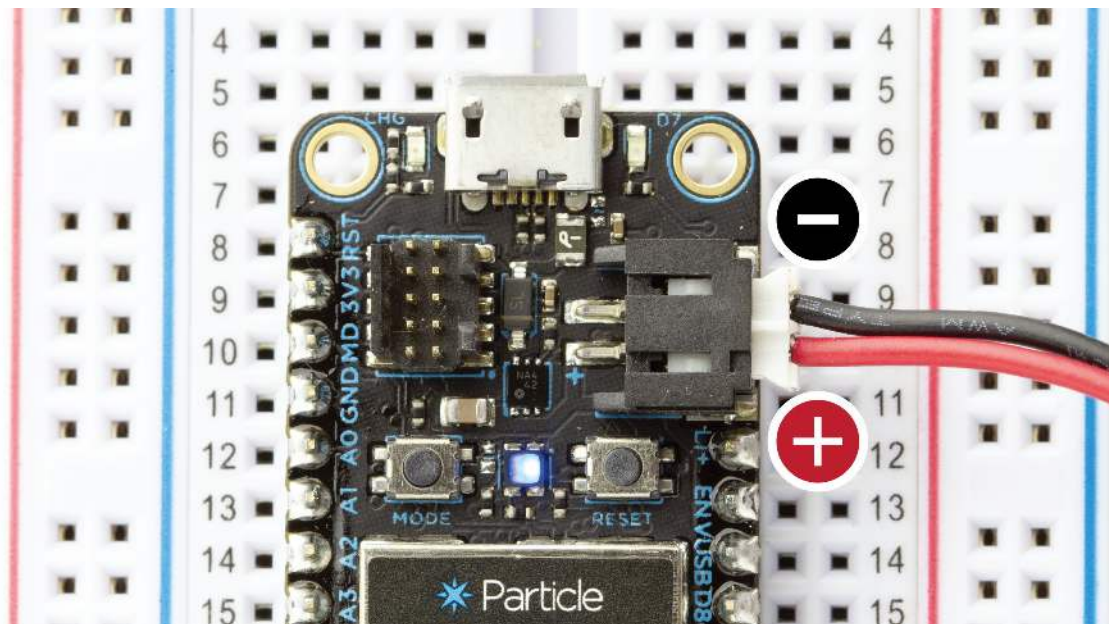

### Li+ pin

This pin is internally connected to the positive terminal of the LiPo connector. You can connect a single cell LiPo/Lithium Ion or a DC supply source to this pin for powering the Argon. Remember that the input voltage range on this pin is 3.6 to 4.2 VDC.

### 3V3 PIN

This pin is the output of the on board 3.3V step-down switching regulator (Torex XC9258A). The regulator is rated at 1000mA max. When using this pin to power other devices or peripherals remember to budget in the current requirement of the Argon first. Unlike the Photon, this pin **CANNOT** be used to power the Argon.

### EN pin

The **EN** pin is not a power pin, per se, but it controls the 3V3 power. The EN pin is pulled high by a 100K resistor to the higher of VUSB, the micro USB connector, or Li+. Because the pull-up can result in voltages near 5V you should never directly connect EN to a 3.3V GPIO pin. Instead, you should only pull EN low, such as by using an N-channel MOSFET or other open-collector transistor.

The EN pin can force the device into a deep power-down state where it uses very little power. It also can be used to assure that the device is completely reset, similar to unplugging it, with one caveat:

If using the EN pin to deeply reset the device, you must be careful not to allow leakage current back into the nRF52 MCU by GPIO or by pull-ups to 3V3. If you only power external devices by 3V3 you won't run into this, as 3V3 is de-powered when EN is low.

However, if you have circuitry that is powered by a separate, external power supply, you must be careful. An externally powered circuit that drives a nRF52 GPIO high when EN is low can provide enough current to keep the nRF52 from powering down and resetting. Likewise, a pull-up to an external power supply can do the same thing. Be sure that in no circumstances can power be supplied to the nRF52 when 3V3 is de-powered.

[See the power supply schematic](#), below, for more information.

## ANTENNA

---

There are two radios on the Argon. A BLE radio (nRF52840) and a Wi-Fi radio (ESP32). For the Wi-Fi radio, we have provided a u.FL connector to plug in the Wi-Fi antenna. This is required if you wish to use the Wi-Fi connectivity.

There are two options for the BLE antenna on the Argon. It comes with an on-board PCB antenna which is selected by default in the device OS and a u.FL connector if you wish to connect an external antenna. If you wish to use the external antenna, you'll need to issue an appropriate command in the firmware.

## FCC APPROVED ANTENNAS

---

### BLE and Wi-Fi

The Argon includes one of these antennas, but a second for use with BLE can be purchased in the [Particle online store](#).

Particle Device	Frequency	Antenna Type	Manufacturer	MFG. Part #	Gain
Argon	2400-2500 MHz	PCB Antenna	Particle	ANT-FLXV2	2.0dBi peak

## PERIPHERALS AND GPIO

---

Peripheral Type	Qty	Input(I) / Output(O)
Digital	20	I/O
Analog (ADC)	6	I
UART	1	I/O
SPI	2	I/O
I2C	2	I/O
USB	1	I/O
PWM	8	O

**Note:** All GPIOs are only rated at 3.3VDC max.

## SWD

---

The Argon has a dedicated 10 pin debug connector that exposes the SWD interface of the nRF5280. This interface can be used to debug your code or reprogram your Argon bootloader, device OS, or the user firmware using any standard SWD tools including our Gen 3 Debugger.

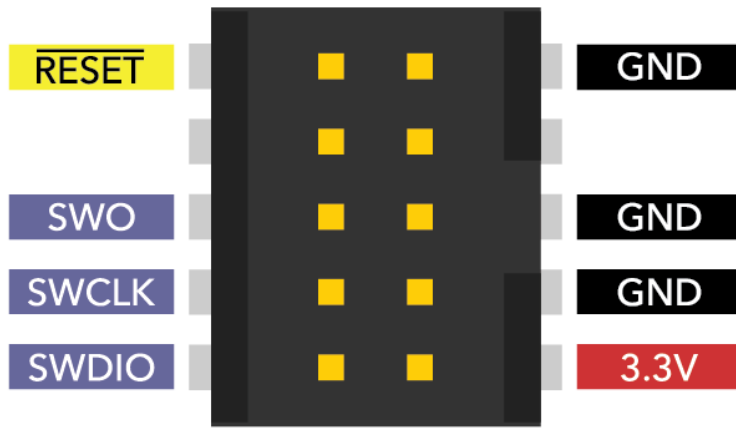

# Memory map

## **NRF52840 FLASH LAYOUT OVERVIEW**

---

- Bootloader (48KB, @0xF4000)
- User Application
  - 256KB @ 0xB4000 (Device OS 3.1 and later)
  - 128KB @ 0xD4000 (Device OS 3.0 and earlier)
- System (656KB, @0x30000)
- SoftDevice (192KB)

## **EXTERNAL SPI FLASH LAYOUT OVERVIEW (DFU OFFSET: 0X80000000)**

---

- OTA (1500KB, @0x00289000)
- Reserved (420KB, @0x00220000)
- FAC (128KB, @0x00200000)
- LittleFS (2M, @0x00000000)

# Pins and button definitions

## PIN MARKINGS



- 1 USB
- 2 MODE BUTTON
- 3 RESET BUTTON
- 4 RGB STATUS LED
- 5 CHARGE STATUS LED
- 6 USER LED (ON D7)
- 7 LiPo BATT CONNECTOR
- 8 DEBUG CONNECTOR (SWD)
- 9 u.FL CONNECTOR FOR WiFi ANTENNA (REQUIRED)
- 10 u.FL CONNECTOR FOR EXTERNAL MESH ANTENNA (OPTIONAL)

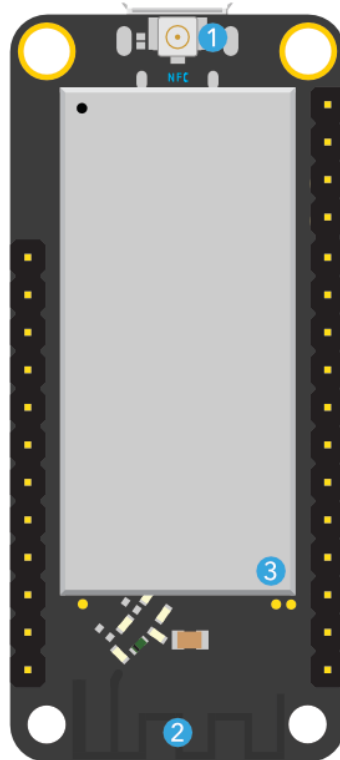

- 1 u.FL CONNECTOR FOR NFC ANTENNA
- 2 ON-BOARD PCB ANTENNA FOR MESH
- 3 RF SHIELD

## PINOUT DIAGRAM



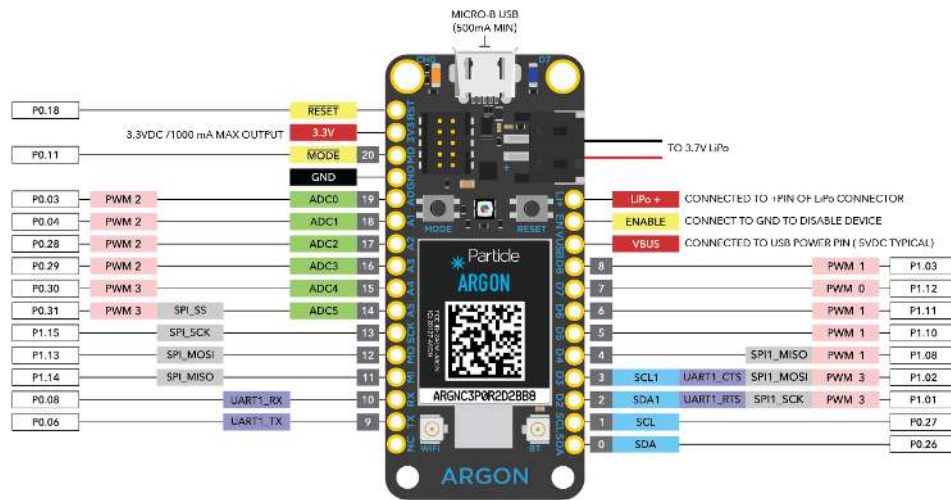

<span style="background-color: #f8d7da; padding: 2px;">PWM 0</span> GROUP 0 PWM PINS	<span style="background-color: #d4edda; padding: 2px;">ADC</span> ANALOG TO DIGITAL INPUT PINS	<span style="background-color: #d1ecf1; padding: 2px;">UART1</span> SERIAL COMMUNICATION PINS (SERIAL1)
<span style="background-color: #f8d7da; padding: 2px;">PWM 1</span> GROUP 1 PWM PINS	<span style="background-color: #d4edda; padding: 2px;">SDA/SCL</span> I2C COMMUNICATION PINS (WIRE)	<span style="background-color: #d1ecf1; padding: 2px;">SDA1/SCL1</span> I2C COMMUNICATION PINS (WIRE1)
<span style="background-color: #f8d7da; padding: 2px;">PWM 2</span> GROUP 2 PWM PINS	<span style="background-color: #d4edda; padding: 2px;">SPI</span> SPI COMMUNICATION PINS (SPI)	<span style="background-color: #d1ecf1; padding: 2px;">SPI1</span> SPI COMMUNICATION PINS (SPI1)
<span style="background-color: #f8d7da; padding: 2px;">PWM 3</span> GROUP 3 PWM PINS	<span style="border: 1px solid #ccc; padding: 2px;">PX,XX</span> nRF52840 PIN NAMES	

v1.0

You can download a high resolution [PDF version of the pin out here.](#)

## PIN DESCRIPTION

Pin	Description
Li+	This pin is internally connected to the positive terminal of the LiPo battery connector.
VUSB	This pin is internally connected to the USB (+ve) supply.
3V3	This pin is the output of the on-board 3.3V regulator.
GND	System ground pin.
EN	Device enable pin is internally pulled-up. To disable the device, connect this pin to GND.
RST	Active-low system reset input. This pin is internally pulled-up.
MD	This pin is internally connected to the MODE button. The MODE function is active-low.
RX	Primarily used as UART RX, but can also be used as a digital GPIO.
TX	Primarily used as UART TX, but can also be used as a digital GPIO.
SDA	Primarily used as data pin for I2C, but can also be used as a digital GPIO.
SCL	Primarily used as clock pin for I2C, but can also be used as a digital GPIO.
MO,MI,SCK	These are the SPI interface pins, but can also be used as a digital GPIO.
D2-D8	These are generic GPIO pins. D2-D8 are PWM-able.
A0-A5	These are analog input pins that can also act as standard digital GPIO. A0-A5 are PWM-able.

## LED STATUS

---

### System RGB LED

For a detailed explanation of different color codes of the RGB system LED, please take a look [here](#).

### Charge status LED

State	Description
ON	Charging in progress
OFF	Charging complete

# Technical specifications

## ABSOLUTE MAXIMUM RATINGS <sup>[1]</sup>

---

Parameter	Symbol	Min	Typ	Max	Unit
Supply Input Voltage	V <sub>IN-MAX</sub>			+6.2	V
Battery Input Voltage	V <sub>LiPo</sub>			+6.5	V
Supply Output Current	I <sub>3V3-MAX-L</sub>			1000	mA
Storage Temperature	T <sub>stg</sub>	-30		+75	°C
ESD Susceptibility HBM (Human Body Mode)	V <sub>ESD</sub>			2	kV

<sup>[1]</sup> Stresses beyond those listed under absolute maximum ratings may cause permanent damage to the device. These are stress ratings only, and functional operation of the device at these or any other conditions beyond those indicated under recommended operating conditions is not implied. Exposure to absolute-maximum-rated conditions for extended periods may affect device reliability.

## RECOMMENDED OPERATING CONDITIONS

---

Parameter	Symbol	Min	Typ	Max	Unit
LiPo Battery Voltage	V <sub>LiPo</sub>	+3.3		+4.4	V
Supply Input Voltage	V <sub>3V3</sub>	+3.0	+3.3	+3.6	V
Supply Output Voltage	V <sub>3V3</sub>		+3.3		V
Operating Temperature	T <sub>op</sub>	-20		+60	°C
Humidity Range Non condensing, relative humidity				95	%

## POWER CONSUMPTION

Parameter	Symbol	Min	Typ	Peak	Unit
Operating Current (uC on, peripherals and radio disabled)	I <sub>idle</sub>	3.1	3.52	3.58	mA
Operating Current (uC on, radio connected but idle)	I <sub>wifi_cloud_idle</sub>	20.5	25.8	219	mA
Operating Current (uC on, radio connected and transmitting)	I <sub>wifi_cloud_tx</sub>	20.1	31.7	261	mA
STOP mode sleep, GPIO wake-up	I <sub>stop_gpio</sub>	350	396	459	uA
STOP mode sleep, analog wake-up	I <sub>stop_analog</sub>	349	398	456	uA
STOP mode sleep, RTC wake-up	I <sub>stop_intrtc</sub>	340	398	461	uA
STOP mode sleep, BLE wake-up, advertising	I <sub>stop_ble_adv</sub>	340	442	3420	uA
STOP mode sleep, BLE wake-up, connected	I <sub>stop_ble_conn</sub>	102	435	1970	uA
STOP mode sleep, serial wake-up	I <sub>stop_usart</sub>	348	397	449	uA
STOP mode sleep, Wi-Fi wake-up	I <sub>stop_wifi</sub>	15.3	22.2	110	mA
ULP mode sleep, GPIO wake-up	I <sub>ulp_gpio</sub>		81.7	169	uA
ULP mode sleep, analog wake-up	I <sub>ulp_analog</sub>		81.1	174	uA
ULP mode sleep, RTC wake-up	I <sub>ulp_intrtc</sub>		80.7	168	uA
ULP mode sleep, BLE wake-up, advertising	I <sub>ulp_ble_adv</sub>		141	3280	uA
ULP mode sleep, BLE wake-up, connected	I <sub>ulp_ble_conn</sub>		138	1870	uA
ULP mode sleep, serial wake-up	I <sub>ulp_usart</sub>	476	520	569	uA
ULP mode sleep, Wi-Fi wake-up	I <sub>ulp_wifi</sub>	16.3	21.3	105	mA
HIBERNATE mode sleep, GPIO wake-up	I <sub>hib_gpio</sub>		64.7	161	uA
HIBERNATE mode sleep, analog wake-up	I <sub>hib_analog</sub>		65.0	159	uA
Power disabled (EN pin = LOW)	I <sub>disable</sub>		20	30	uA

<sup>1</sup>The min, and particularly peak, values may consist of very short transients. The typical (typ) values are the best indicator of overall power consumption over time. The peak values indicate the absolute minimum capacity of the power supply necessary, not overall consumption.

## RADIO SPECIFICATIONS

Argon has two radio modules.

Nordic Semiconductor nRF52840 SoC for BLE and NFC.

Feature	Description
Operating Frequencies	2360 to 2500 MHz
Output Power	Programmable -20dBm to +8dBm
PLL channel spacing	1 MHz
On the air data rate	125 to 2000 kbps

Espressif Systems ESP32 for Wi-Fi

Feature	Description
WLAN Standards	IEEE 802.11b/g/n
Antenna Port	Single Antenna
Frequency Band	2412 to 2484 MHz

**Note:** Bluetooth features of the ESP32 are not exposed.

## I/O CHARACTERISTICS

---

These specifications are based on the nRF52840 datasheet.

Parameter	Symbol	Conditions	Min	Typ	Max	Unit
Input high voltage	$V_{IH}$		0.7*3.3	--	3.3	V
Input low voltage	$V_{IL}$		0		0.3*3.3	V
Current at GND+0.4 V, output set low, high drive	$I_{OL,HDL}$	$V_{3V3} \geq 2.7V$	6	10	15	mA
Current at $V_{3V3}$ -0.4 V, output set high, high drive	$I_{OH,HDH}$	$V_{3V3} \geq 2.7V$	6	9	14	mA
Current at GND+0.4 V, output set low, standard drive	$I_{OL,SD}$	$V_{3V3} \geq 2.7V$	1	2	4	mA
Current at $V_{3V3}$ -0.4 V, output set high, standard drive	$I_{OH,SD}$	$V_{3V3} \geq 2.7V$	1	2	4	mA
Pull-up resistance	$R_{PU}$		11	13	16	k $\Omega$
Pull-down resistance	$R_{PD}$		11	13	16	k $\Omega$

GPIO default to standard drive (2mA) but can be reconfigured to high drive (9mA) in Device OS 2.0.0 and later using the `pinSetDriveStrength()` function.

# Mechanical specifications

## DIMENSIONS AND WEIGHT

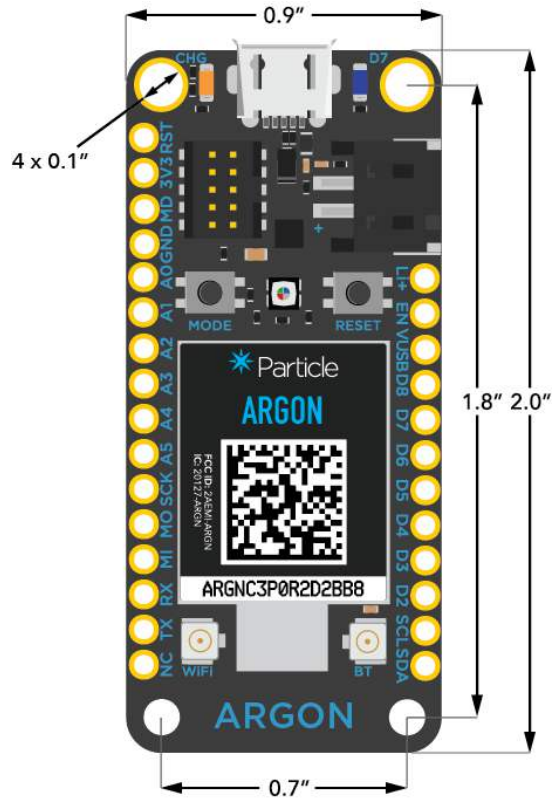

- Weight = 10 grams

## 3D MODELS

3D models of the Argon are available in the [hardware-libraries Github](#) in formats including step, iges, stl, and f3d.

## MATING CONNECTORS

The Argon uses two single row 0.1" pitch male header pins. One of them is 16 pin while the other is 12 pin. It can be mounted with matching 0.1" pitch female headers with a typical height of 0.335" (8.5mm). When you search for parts like these it can be difficult to navigate the thousands of parts available online so here are a few good choices for the Argon:

Description	MFG	MFG Part Number
16-pin 0.1" (2.54mm) Female Header	Sullins	PPTC161LFBN-RC
16-pin 0.1" (2.54mm) Female Header	TE	6-535541-4
12-pin 0.1" (2.54mm) Female Header	Sullins	PPTC121LFBN-RC
12-pin 0.1" (2.54mm) Female Header	TE	6-534237-0



# Schematic

The complete schematic and board files are open source and available on Particle's GitHub repository [here](#).

## POWER

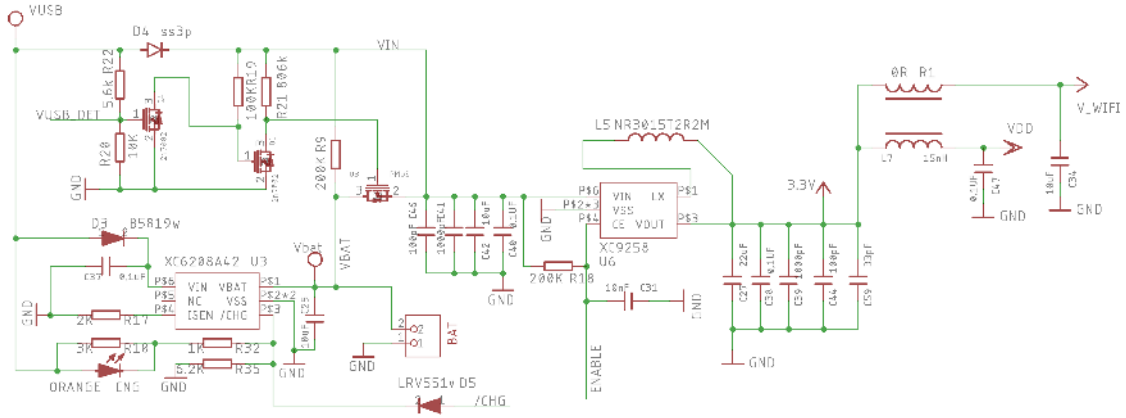

## NRF52840

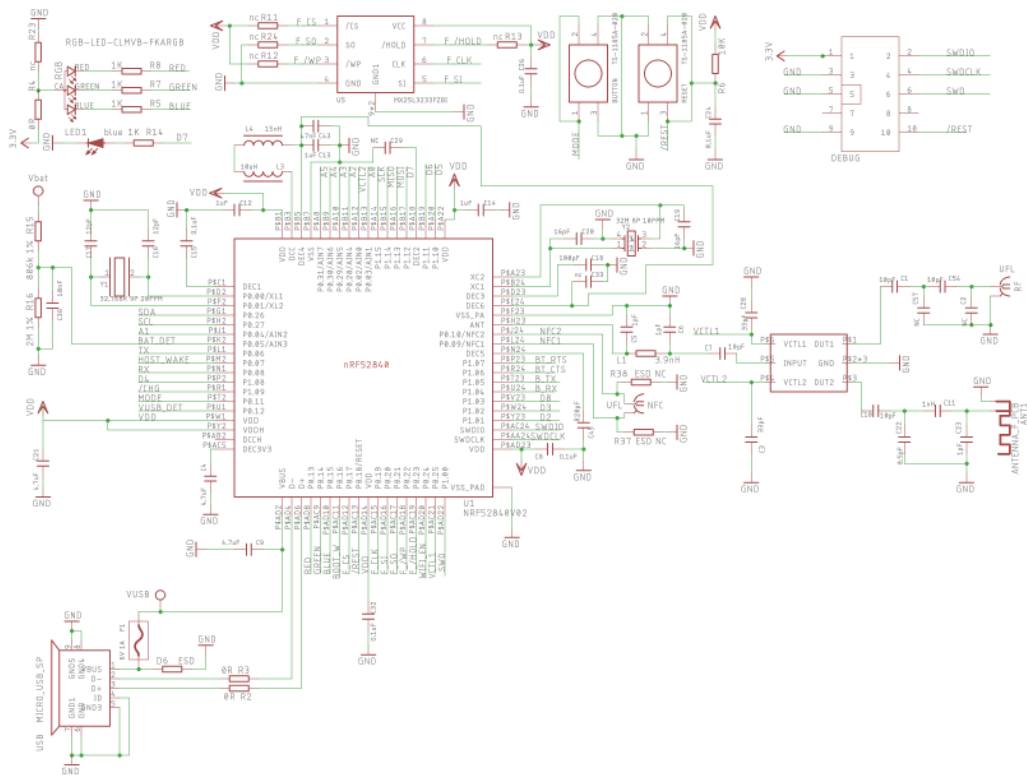

## ESP32



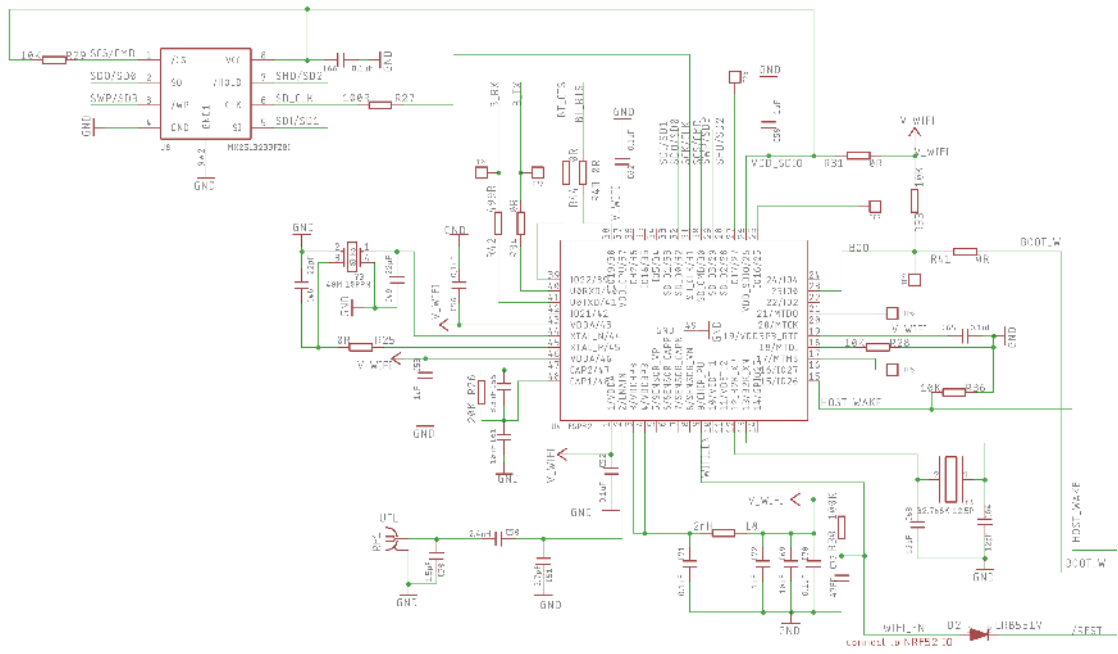

# Ordering information

Argon are available from [store.particle.io](https://store.particle.io) in single quantities.

<b>SKU</b>	<b>Description</b>	<b>Region</b>	<b>Lifecycle</b>	<b>Replacement</b>
ARG-AQKT	Argon Air Quality Monitor Kit [x1]	Global	NRND	
ARG-STRTKT	Argon Starter Kit [x1]	Global	NRND	
ARGN-H	Argon [x1]	Global	NRND	
ARGNKIT	Argon, Starter Kit [x1]	Global	NRND	
ARGNTRAY50	Argon, Tray [x50]	Global	NRND	
ARG-LDKT	Argon Leak Detection Kit [x1]	Global	Deprecated	

## Qualification and approvals



- Model Number: ARGN
- RoHS
- CE
- FCC ID: 2AEMI-ARGN
- IC: 20127-ARGN

# Product handling

## ESD PRECAUTIONS

The Argon contains highly sensitive electronic circuitry and is an Electrostatic Sensitive Device (ESD). Handling Argon without proper ESD protection may destroy or damage it permanently. Proper ESD handling and packaging procedures must be applied throughout the processing, handling and operation of any application that incorporates Argon. ESD precautions should be implemented on the application board where the Argon is mounted. Failure to observe these precautions can result in severe damage to the Argon!

## CONNECTORS

There are four connectors on the Argon that will get damaged with improper usage. The JST connector on the circuit board, where you plug in the LiPo battery, is very durable but the connector on the battery itself is not. When unplugging the battery, take extra precaution to **NOT** pull the connector using the wires, but instead hold the plug at its base to avoid putting stress on the wires. This can be tricky with bare hands - needle nose pliers are your friend here.

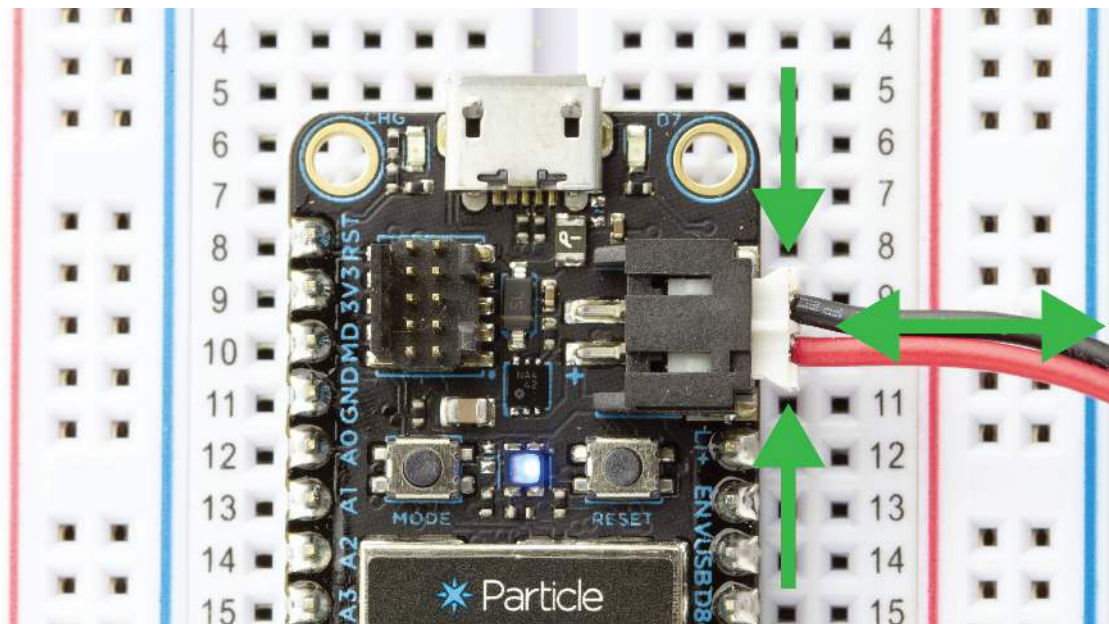

The micro B USB connector on the Argon is soldered on the PCB with large surface pads as well as couple of through hole anchor points. Despite this reinforcement, it is very easy to rip out the connector if too much stress is put on in the vertical direction.

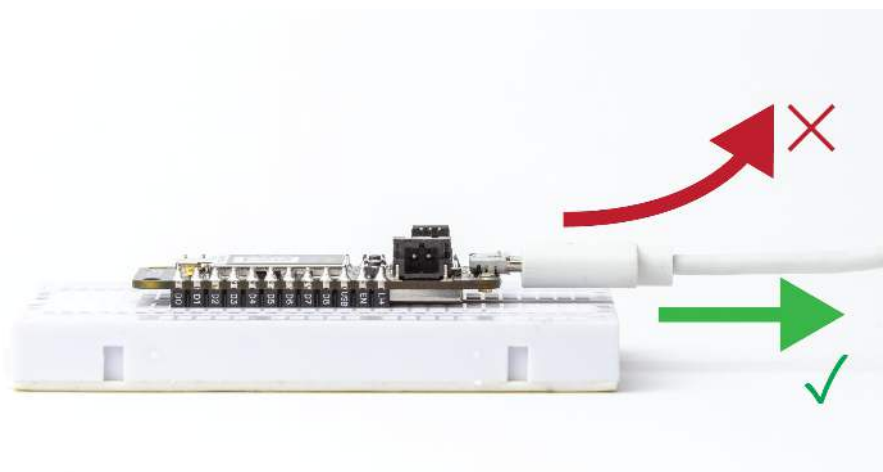

The U.FL antenna connector is not designed to be constantly plugged and unplugged. The antenna pin is static sensitive and you can destroy the radio with improper handling. A tiny dab of

glue (epoxy, rubber cement, liquid tape or hot glue) on the connector can be used to securely hold the plug in place.

The 10 pin SWD connector provides an easy in-system debugging access to the device. The pins on the connector can easily be damaged if the mating connector cable is inserted improperly. If you are trying to debug the device, you probably are already not in a good mood. The last thing you want is to render the connector useless. Be nice and be gentle with the connector. Good luck with the debugging!

## **BREADBOARDING**

---

The breadboard provided with the Argon is specifically designed to require low insertion force. This makes it easy to plug the Argon in and out of the breadboard. If you end up using a different breadboard, remember that it may require more force. In this case, always remember to pinch-hold your precious Argon by the sides (along the header pins) when plugging-unplugging and not by the USB connector (don't be this person).

## Default settings

The Argon comes preprogrammed with a bootloader and a user application called Tinker. This application works with an iOS and Android app also named Tinker that allows you to very easily toggle digital pins, take analog and digital readings and drive variable PWM outputs.

The bootloader allows you to easily update the user application via several different methods, USB, OTA, Serial Y-Modem, and also internally via the Factory Reset procedure. All of these methods have multiple tools associated with them as well.

# FCC IC CE warnings and end product labeling requirements

**Federal Communication Commission Interference Statement** This equipment has been tested and found to comply with the limits for a Class B digital device, pursuant to Part 15 of the FCC Rules. These limits are designed to provide reasonable protection against harmful interference in a residential installation. This equipment generates, uses and can radiate radio frequency energy and, if not installed and used in accordance with the instructions, may cause harmful interference to radio communications. However, there is no guarantee that interference will not occur in a particular installation. If this equipment does cause harmful interference to radio or television reception, which can be determined by turning the equipment off and on, the user is encouraged to try to correct the interference by one of the following measures:

- Reorient or relocate the receiving antenna.
- Increase the separation between the equipment and receiver.
- Connect the equipment into an outlet on a circuit different from that to which the receiver is connected.
- Consult the dealer or an experienced radio/TV technician for help.

**FCC Caution:** Any changes or modifications not expressly approved by the party responsible for compliance could void the user's authority to operate this equipment. This device complies with Part 15 of the FCC Rules. Operation is subject to the following two conditions:

1. This device may not cause harmful interference, and
2. This device must accept any interference received, including interference that may cause undesired operation.

**FCC Radiation Exposure Statement:** This equipment complies with FCC radiation exposure limits set forth for an uncontrolled environment. This transmitter module must not be co-located or operating in conjunction with any other antenna or transmitter. This End equipment should be installed and operated with a minimum distance of 20 centimeters between the radiator and your body.

**IMPORTANT NOTE:** In the event that these conditions can not be met (for example certain laptop configurations or co-location with another transmitter), then the FCC authorization is no longer considered valid and the FCC ID can not be used on the final product. In these circumstances, the OEM integrator will be responsible for re-evaluating the end product (including the transmitter) and obtaining a separate FCC authorization.

**End Product Labeling** The final end product must be labeled in a visible area with the following:

- Contains FCC ID: 2AEMI-ARGN

**Manual Information to the End User** The OEM integrator has to be aware not to provide information to the end user regarding how to install or remove this RF module in the user's manual of the end product which integrates this module.

**Canada Statement** This device complies with Industry Canada's licence-exempt RSSs. Operation is subject to the following two conditions:

1. This device may not cause interference; and
2. This device must accept any interference, including interference that may cause undesired operation of the device.

Le présent appareil est conforme aux CNR d'Industrie Canada applicables aux appareils radio exempts de licence.

**L'exploitation est autorisée aux deux conditions suivantes:**

1. l'appareil ne doit pas produire de brouillage;
2. l'utilisateur de l'appareil doit accepter tout brouillage radioélectrique subi, même si le brouillage est susceptible d'en compromettre le fonctionnement.

**Caution Exposure:** This device meets the exemption from the routine evaluation limits in section 2.5 of RSS102 and users can obtain Canadian information on RF exposure and compliance. Le dispositif répond à l'exemption des limites d'évaluation de routine dans la section 2.5 de RSS102 et les utilisateurs peuvent obtenir des renseignements canadiens sur l'exposition aux RF et le respect.

**The final end product must be labelled in a visible area with the following:** The Industry Canada certification label of a module shall be clearly visible at all times when installed in the host device, otherwise the host device must be labelled to display the Industry Canada certification number of the module, preceded by the words "Contains transmitter module", or the word "Contains", or similar wording expressing the same meaning, as follows:

- Contains transmitter module IC: 20127-ARGN

This End equipment should be installed and operated with a minimum distance of 20 centimeters between the radiator and your body. Cet équipement devrait être installé et actionné avec une distance minimum de 20 centimètres entre le radiateur et votre corps.

The end user manual shall include all required regulatory information/warning as shown in this manual.



# Revision history

<b>Revision</b>	<b>Date</b>	<b>Author</b>	<b>Comments</b>
v001	2018 Oct 26	MB	Initial release
v002	2020 Jan 21	RK	Remove mesh
v003	2020 Sep 01	RK	Add EN pin information
v004	16-Sep-2020	RK	Added power consumption information
v005	15-Mar-2021	RK	Updated ordering information
v006	28-Jun-2021	RK	Added Device OS 3.1 memory map information
v007	28-Jul-2021	RK	Corrected number of SPI ports (2) in peripherals and GPIO
v008	10-Sep-2021	RK	Changed wording of peak vs. max current
v009	14-Mar-2022	RK	Added deprecation notice
v010	18-May-2023	RK	Add warning that the Argon cannot be powered by 3V3

## Known errata

# Contact

## **Web**

<https://www.particle.io>

## **Community Forums**

<https://community.particle.io>