

DRAWING MADE IN THIRD ANGLE PROJECTION

© COPYRIGHT 19 BY AMP INCORPORATED, HARRISBURG, PA.
ALL INTERNATIONAL RIGHTS RESERVED. AMP INCORPORATED PRODUCTS
COVERED BY U. S. AND FOREIGN PATENTS AND/OR PATENTS PENDING.

LOC AB DIST 39

REVISIONS						
P	F	ZONE	LTR	DESCRIPTION	DATE	APPROVED
		A		ECO-08-020831	PY 10-08	BW

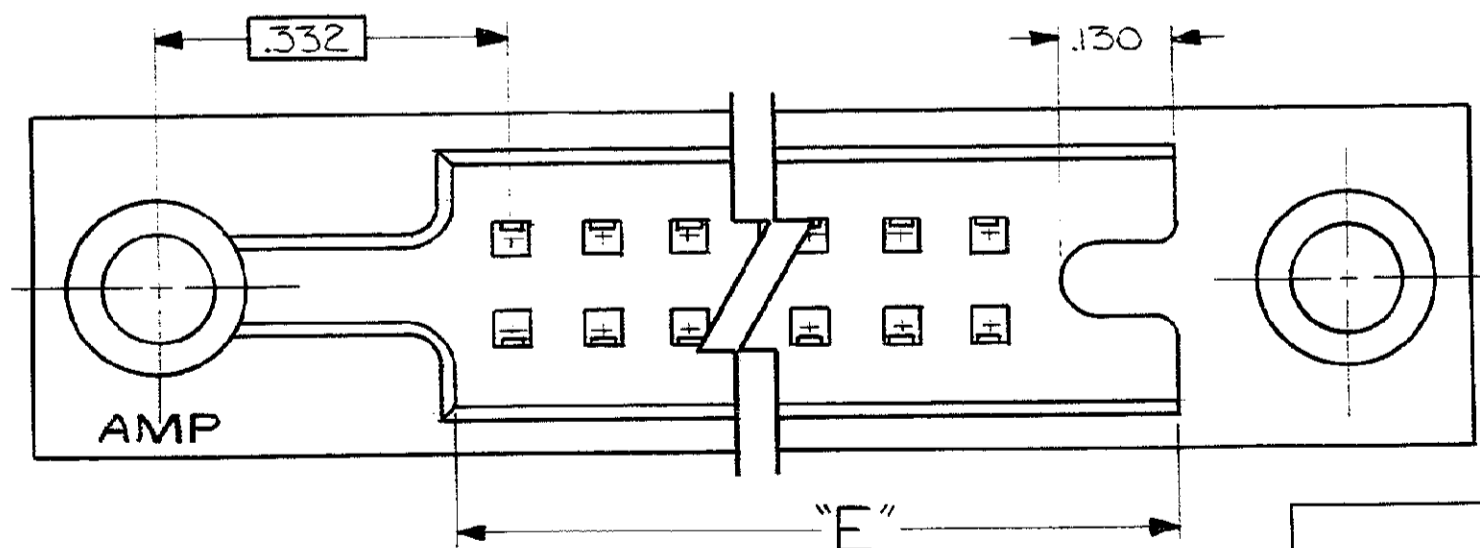
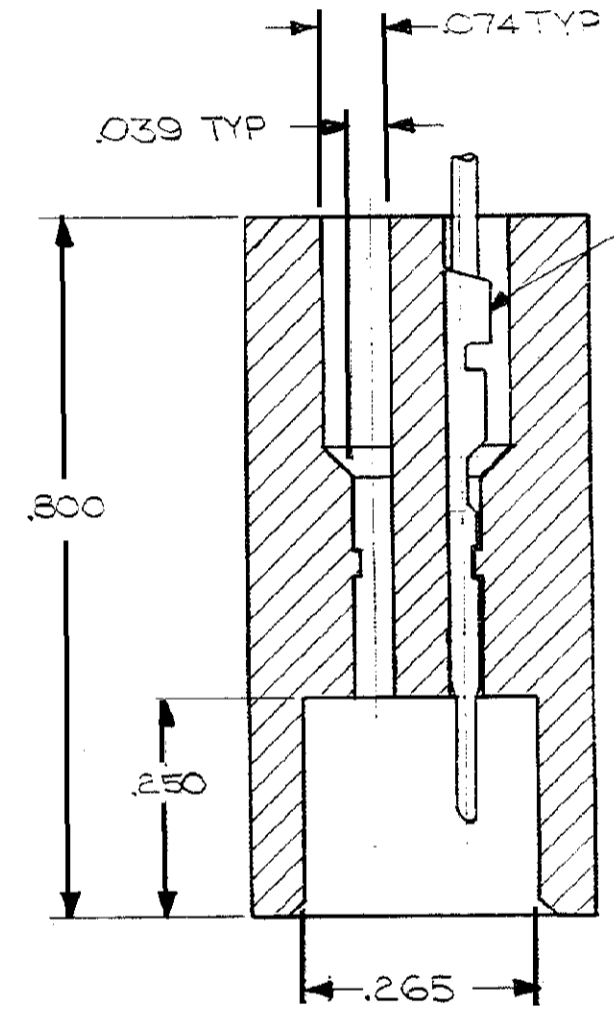
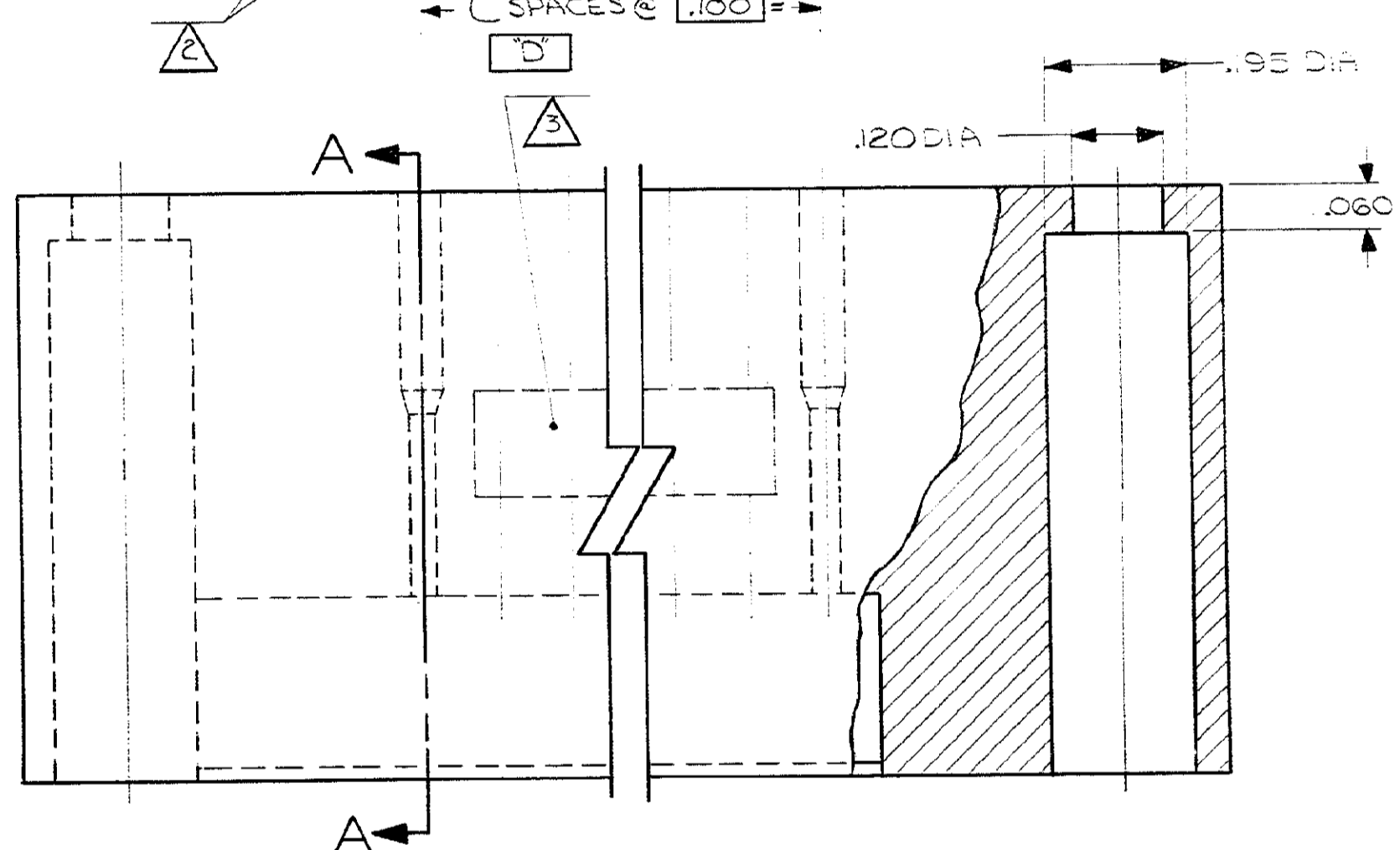
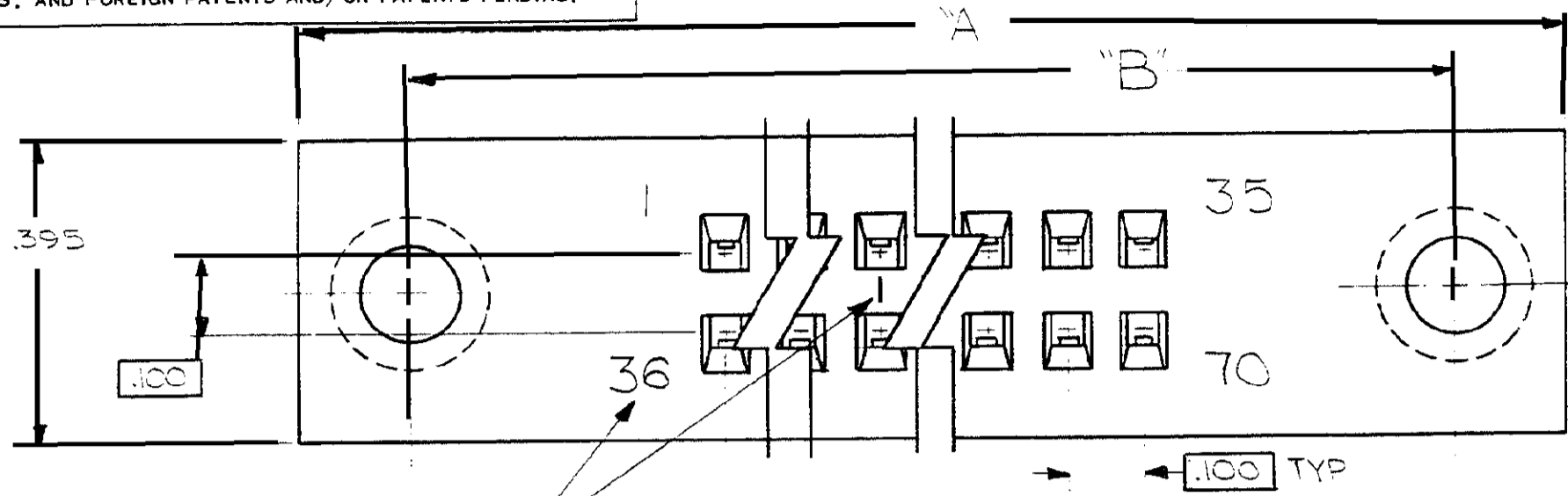

56	55	5.675	5.400	54	6.065	6.355	110	I-530753-8	M55302/113-23
51	50	5.175	4.900	49	5.565	5.855	100	I- -6	-22
46	45	4.675	4.400	44	5.065	5.355	90	I- -4	-21
41	40	4.175	3.900	39	4.565	4.855	80	I- -2	-20
36	35	3.675	3.400	34	4.065	4.355	70	I- -2	-19
31	30	3.175	2.900	29	3.565	3.855	60	I- -0	-18
26	25	2.675	2.400	24	3.065	3.355	50	-8	-17
21	20	2.175	1.900	19	2.565	2.855	40	-6	-16
16	15	1.675	1.400	14	2.065	2.355	30	530753-4	M55302/113-15

- ① MATERIAL: GLASS FILLED POLYESTER - COLOR: BLUE
- ② MARKING - NUMBERS TO BE MARKED $\frac{1}{16}$ HIGH NUMERALS, AND LINES INDICATING EVERY FIVE CAVITIES TO BE MARKED ON REAR SURFACE.
- ③ MARK THIS AREA WITH AMP, PART NO, DATE CODE MIL. PART NO. EXAMPLE: AMP 530753-2, 7814 M55302/113-19.
- 4. MATES WITH M55302/27 STYLE 2 & STYLE 3 RECEPTACLES.

UNLESS OTHERWISE SPECIFIED DIMENSIONS ARE IN INCHES.
TOLERANCES ON:
DECIMALS $\pm .020$
ANGLES $\pm 1^{\circ}30'$

MATERIAL

FINISH

CONTRACT NO
DR 5-22-78
CHK *A. Shante*
CHK *R. W. Durbin* 5-25-78
APPD *Royce Durbin* 5-25-78
APPD *R. Shouman* 5-26-78
DSGN APPD
OTHER APPD

AMP INCORPORATED
Harrisburg, Pa.

NAME
HOUSING-BOX CONTACT

SIZE CODE IDENT NO DRAWING NO REV
C 00779 530753 A

SCALE 5:1 SHEET

530753