

THIS DRAWING IS UNPUBLISHED. RELEASED FOR PUBLICATION
 © COPYRIGHT BY TYCO ELECTRONICS CORPORATION. ALL RIGHTS RESERVED.

LOC	DIST	REVISIONS					
		P	LTR	DESCRIPTION	DATE	DWN	APVD
AJ	16	0		REV PER EC-0S14-0496-04	01FEB2005	GA	GM
		01		REVISED PER ECO-09-024927	04NOV09	KK	AEG

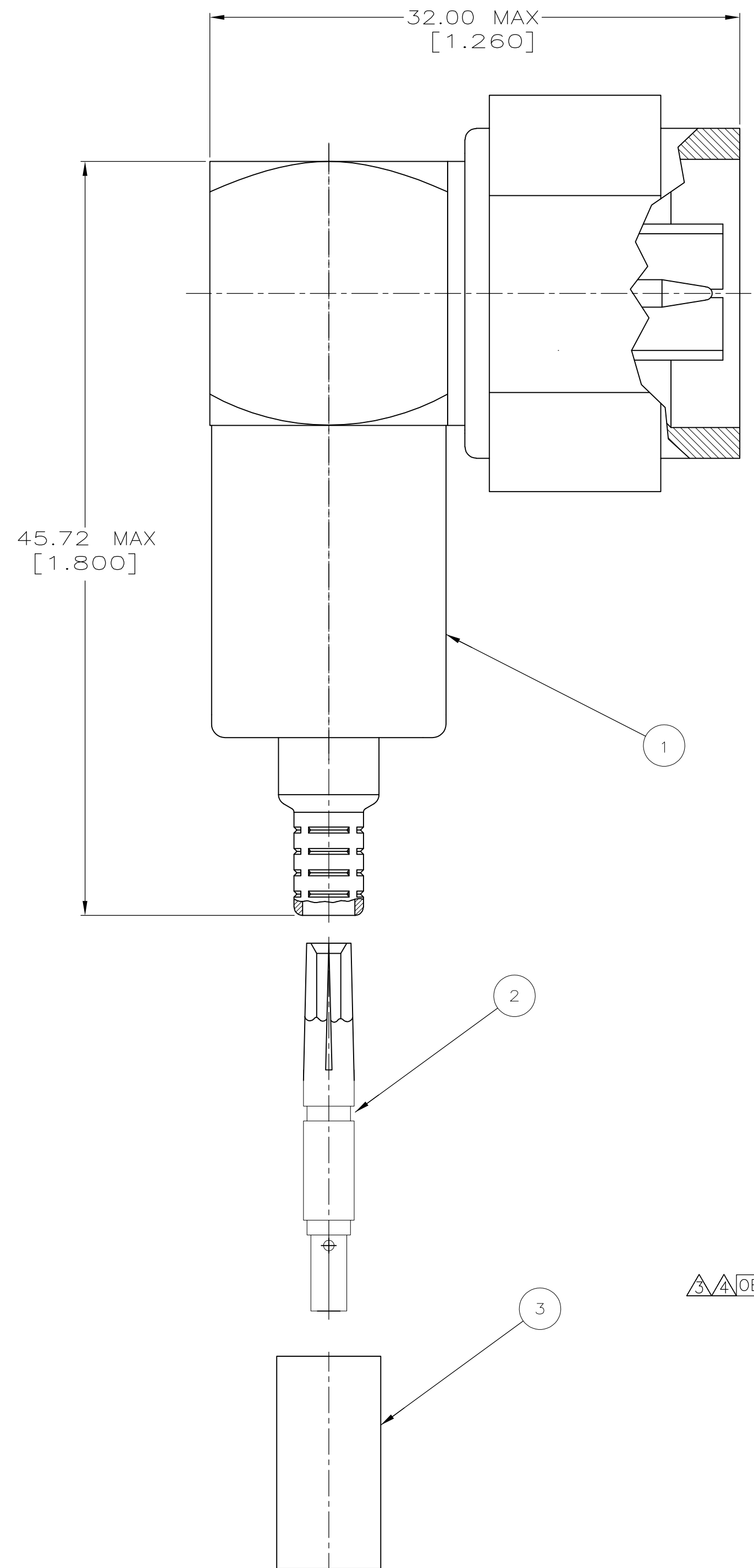

- 1. FOR USE WITH AMP PRO-CRIMPER II HAND TOOL, PART # 354940-1, OR WITH THE 626 SERIES PNEUMATIC TOOL WITH ADAPTER #679304-1
- ⚠ REQUIRES PRO-CRIMPER II DIE SET PART # 58436-1. FOR CONTACT AND BRAID TERMINATION.
- ⚠ REQUIRES PRO-CRIMPER II DIE SET PART # 58485-1. FOR CONTACT AND BRAID TERMINATION.
- ⚠ OBSOLETE PARTS: OBSOLETE CIS STREAMLINING PER D.RENAUD/D.SINISI

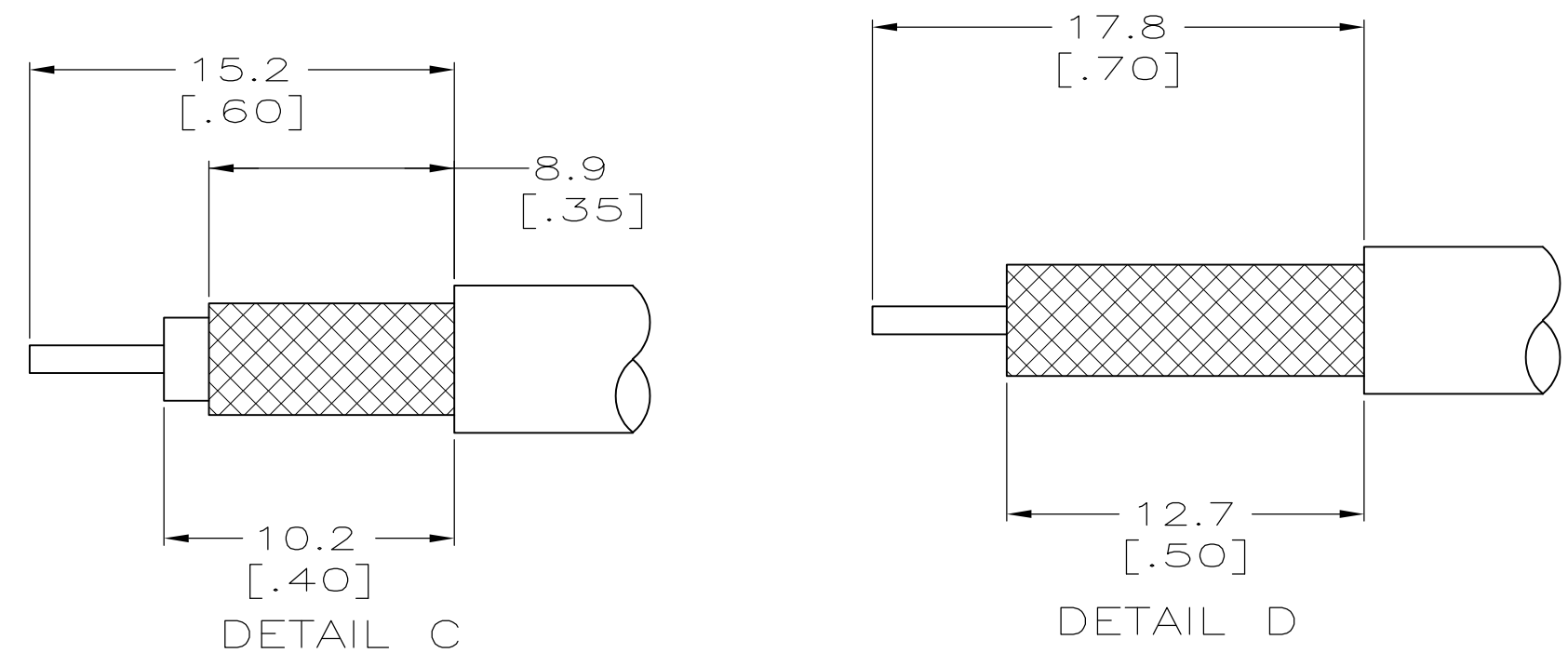

RECOMMENDED STRIP LENGTHS

⚠⚠ OBSOLETE	RG-9/U & 214/U	CONTACT: .100, BRAID: .429	DETAIL D	9-221132-5	415247-4	415256-2	-5415255-4-
	RG-58/AU & 58C/U	CONTACT: .068, BRAID: .213	DETAIL C	9-221132-0	415246-4	415256-1	5415255-1
	CABLE	HEX CRIMP HEIGHTS IN INCHES	STRIP LENGTH	③ FERRULE QTY=1	② CONTACT QTY=1	① PLUG ASSY QTY=1	PART NUMBER

THIS DRAWING IS A CONTROLLED DOCUMENT.

DIMENSIONS: mm [inches]	TOLERANCES UNLESS OTHERWISE SPECIFIED: 0 PLC ± - 1 PLC ± 0.5 [.02] 2 PLC ± - 3 PLC ± - 4 PLC ± - ANGLES ± - FINISH -	DWN G. ATTADIA - DOCK5 CHK J. HAVENER APVD G. MICHAEL PRODUCT SPEC - APPLICATION SPEC - WEIGHT -	01FEB2005 01FEB2005 01FEB2005	Tyco Electronics Corporation Harrisburg, PA 17105-3608
MATERIAL -	FINISH -	NAME PLUG, RIGHT ANGLE, SERIES N	SIZE A2 CAGE CODE 00779 DRAWING NO C=5415255	RESTRICTED TO -
CUSTOMER DRAWING			SCALE 4:1	SHEET 1 OF 1 REV 01