

CD79F



CANTHERM

Supplying high-quality bimetal and thermal sensor products.

THERMAL PROTECTION
FOR MOTOR WINDINGS &
TRANSFORMERS

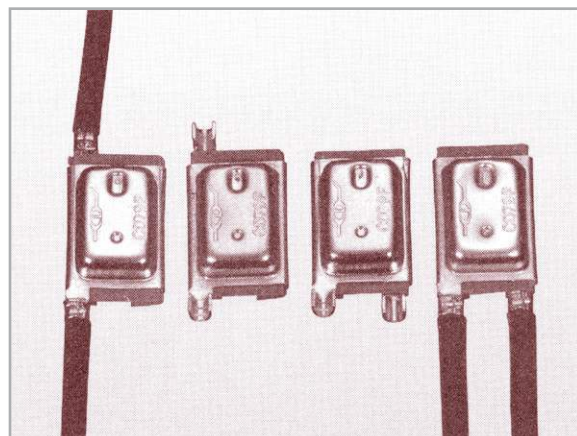

CD79F

Thermal Protection for Motor Windings & Transformers

These thermal protectors operate by means of a thermally sensitive snap action bimetal which switches open a single pole/single throw electrical contact upon reaching a factory calibrated response temperature. Heat transfer occurs on all sides via conduction, convection or radiation. The bimetal disc snaps closed once the reset temperature has been reached.

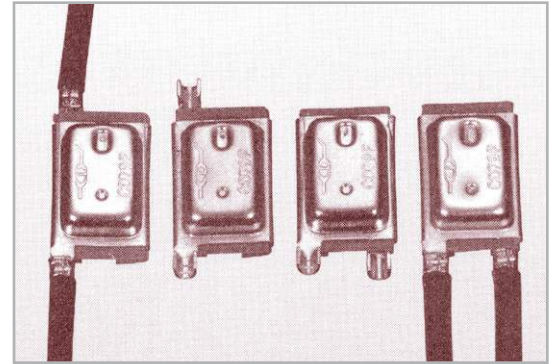

Features

- Snap action accuracy
- Universal size
- Maximum switch load 22 Amps
- Very economical
- Current & temp sensitive

Applications

Single Phase Motors, Generators, Convertors, Transformers, Pumps, Heating Elements, Signal Transmitters, Fire Detectors, Magnets, Relays, Chokes, Coils, Power Supplies, Inverters

Examples

AC Motors, Transformers, Battery packs, Blanket heaters, Heating appliances, Fluorescent light ballasts, Recessed lighting fixtures, Automotive DC Motors, Water bed heaters

Voltage	Current (Res.)	Endurance (No. Cycles)
120 VAC	5 Amperes	100,000
16 VDC	20 Amperes	10,000
120 VAC	22 Amperes	10,000
277 VAC	8 Amperes	10,000

Installation tips

When installing thermal cutouts, it is important to ensure good heat transfer. The heat sensitive surface (base) should be placed on/near to the heat source. Heat conducting paste or paint will improve heat transfer.

It should be noted that standard version thermal cutouts have a current-carrying housing, and that with electrically insulated cutouts the impaired heat transfer can alter the effective switching temperature. This should be borne in mind when selecting the nominal response temperature.

With single-phase motors, the cutout should switch the mains supply. It will then switch the motor off if there is any undesirable heating. The motor short circuit current will then be safely interrupted, if this is larger than the current rating of the cutout.

For three-phase motors, the motor current will not be interrupted direct from the mains supply. The cut-out installed in the windings should switch in series with the magnetic coil of the contactor. The electrical supply to the cutouts should lead either singly or together from the motor terminals so that connection with the control circuit is possible.

Technical data

Contact arrangement	Normally Closed
Contact resistance	<50 MΩ
Response temperature range	65°C to 180°C
Tolerance	+/- 5°C, +/- 10°C
Dielectric Strength	Insulating sleeve withstand 1,500 VAC for 60 seconds or 1,800 VAC for one second, with leakage current less than 10 MA
Insulating resistance	Over 100 Mega Ohm for 500 VDC
Options	Insulating sleeve: Heat shrink, Mylar* spiral wound tube Lead wire: 18, 20 AWG, 300 or 600 volts, 105°C, 125°C, 150°C, 200°C or bare solid tinned copper. *Registered Trademark of E.I. duPont Co.

Current vs Temperature

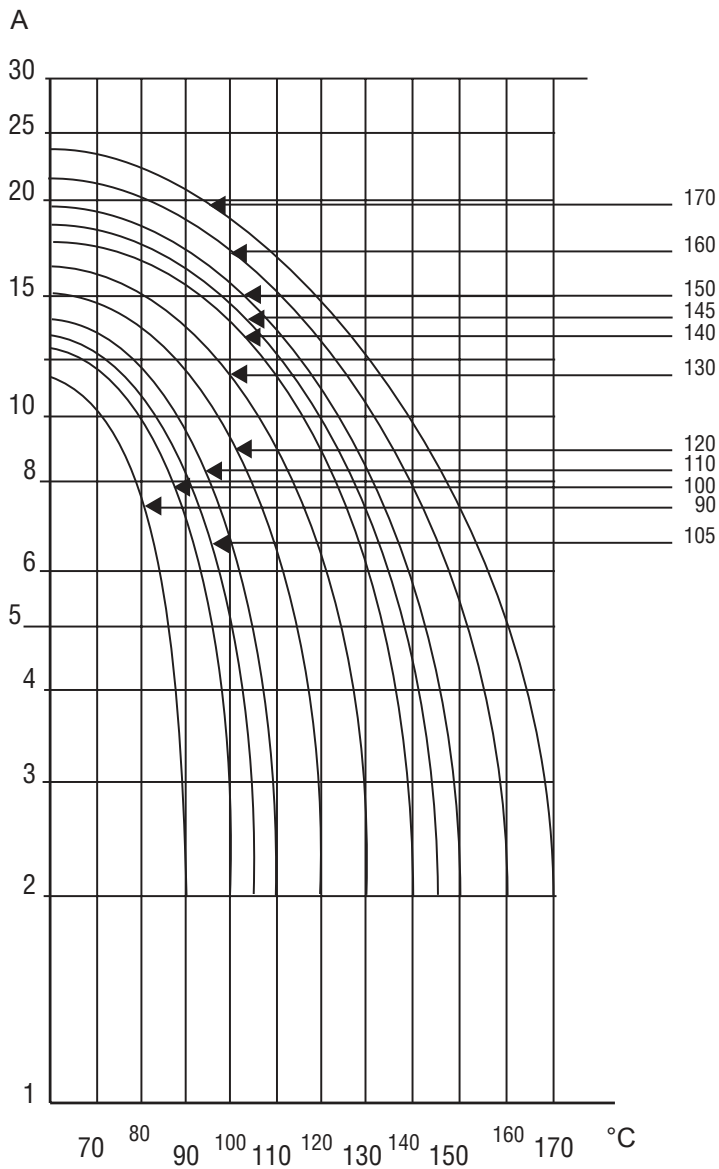

Bimetal resistance 40 ohm This graph shows mean values

Response time vs Current

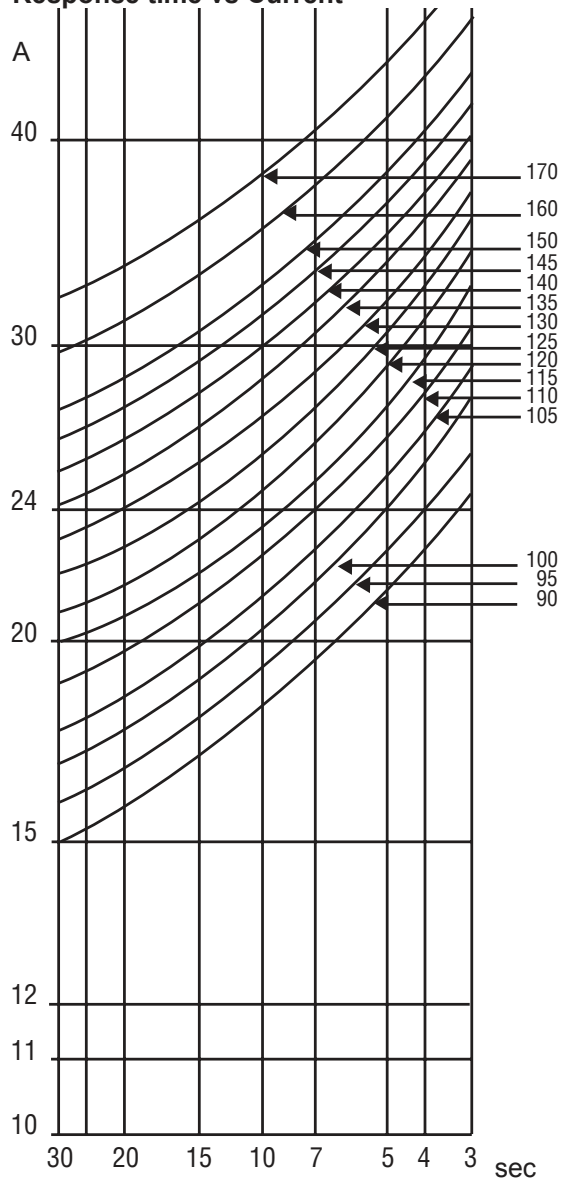

Mean initial cycle response time T 25 C

Specification

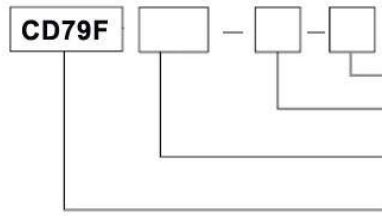

Model: A = Terminals at same end B = Terminals at opposite ends

Tolerance: 05 = $\pm 5^{\circ}\text{C}$ or 10 = $\pm 10^{\circ}\text{C}$

Temperature Range (65°C to 180°C)

Part Number

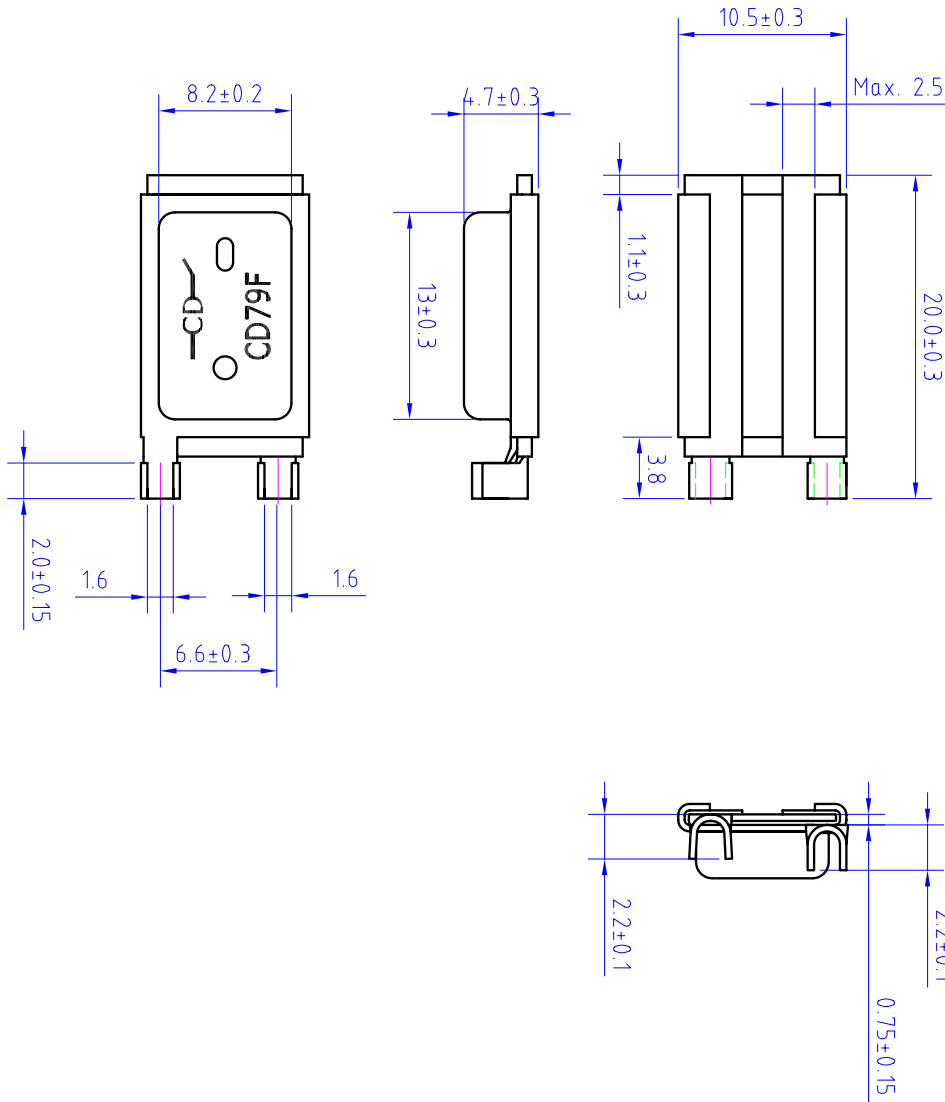

CANTHERM

Supplying high-quality bimetal and thermal sensor products.

8415 Mountain Sights Avenue • Montreal (Quebec), H4P 2B8, Canada

Tel: (514) 739-3274 • 1-800-561-7207 • Fax: (514) 739-2902 • E-mail: sales@cantherm.com

Website: www.cantherm.com | Division of Microtherm