

THIS DRAWING IS UNPUBLISHED. RELEASED FOR PUBLICATION 20  
 © COPYRIGHT 20 BY - TE Connectivity ALL RIGHTS RESERVED.

REVISIONS					
P	LTR	DESCRIPTION	DATE	DWN	APVD
B		REVISED (ECR-06-011820)	09JUN2006	CH	JK
C		REVISED (ECR-10-024983)	07DEC2010	SJ	HG
CI		REVISED (ECR-23-172702)	19APR2023	DG	KT

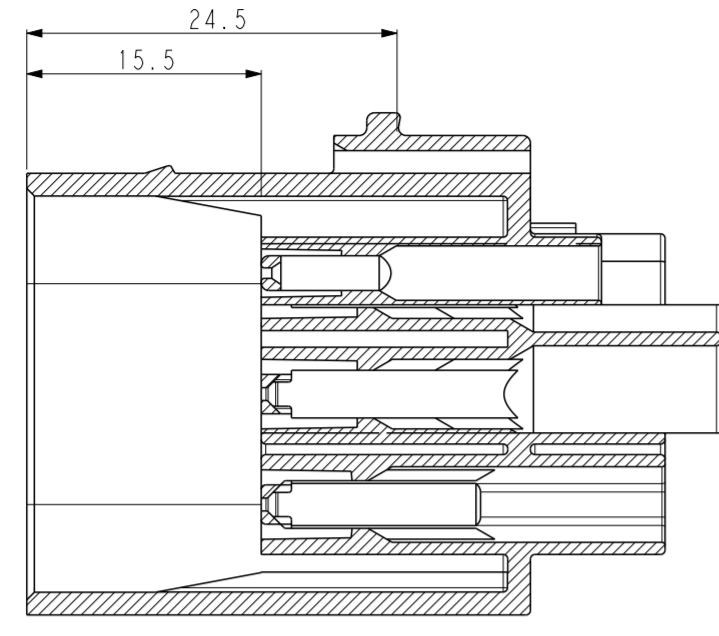

SECTION A-A

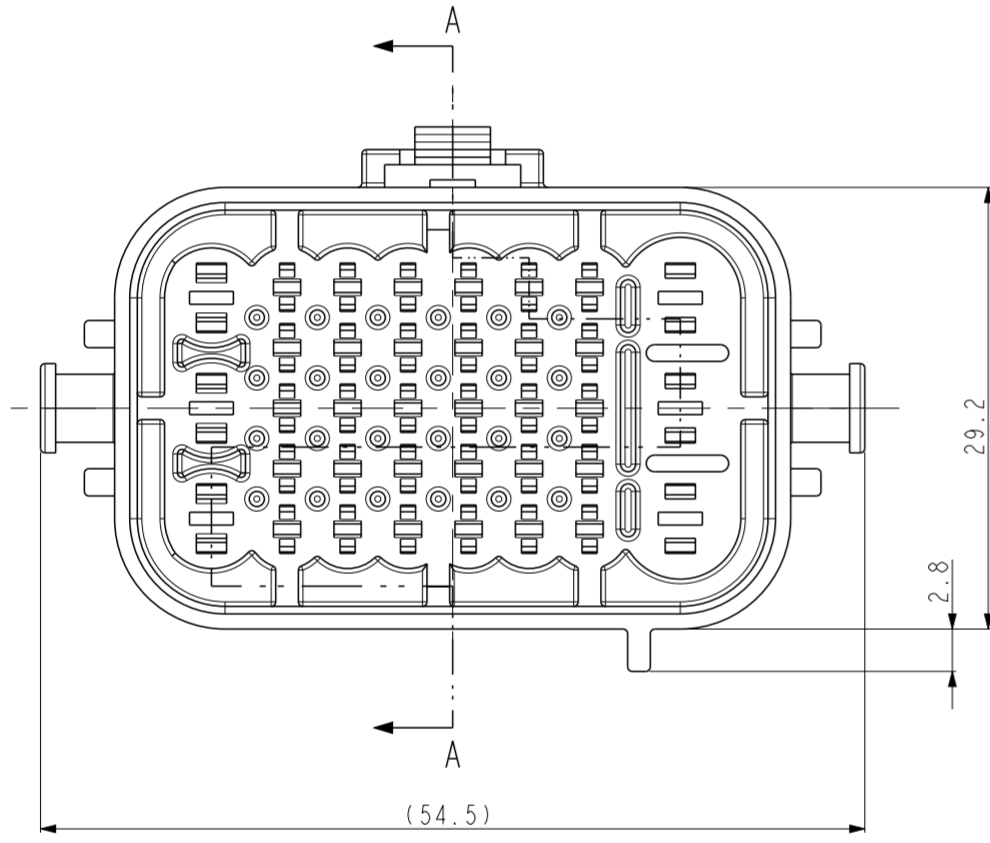
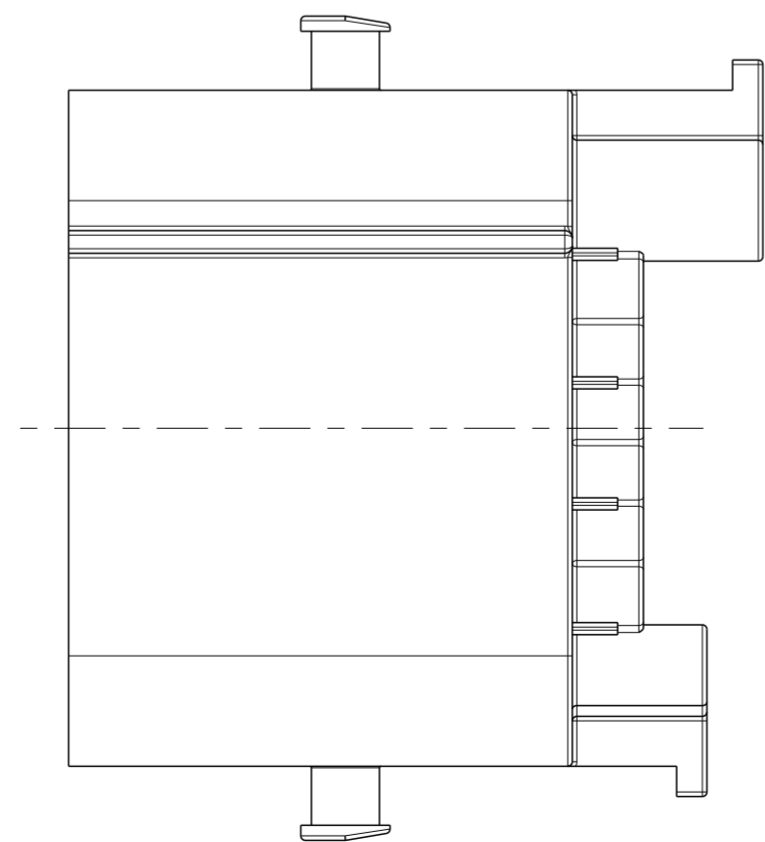
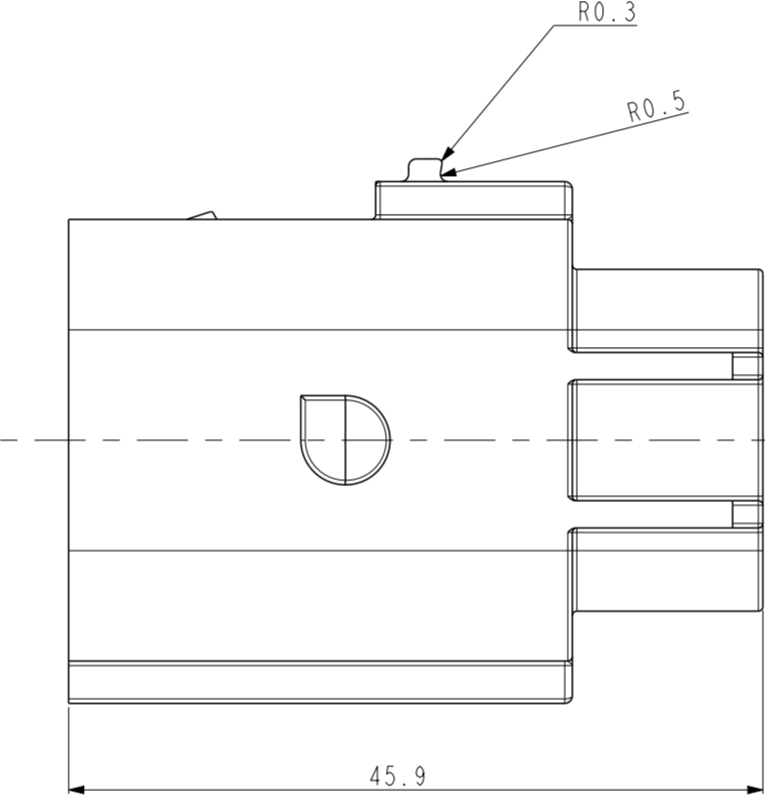
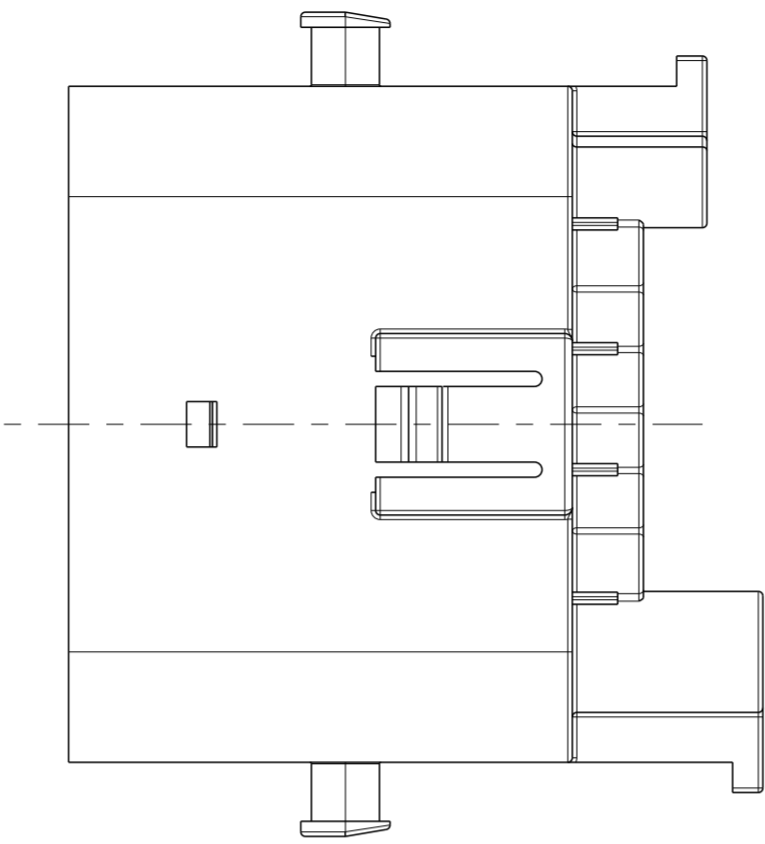

<TABLE 1>

TYPE	PART NO.	WIRE SIZE(mm <sup>2</sup> )	Insulation DIA(mm)	Applicable WIRE	FINISH
MTII	0-963902-1	0.2~0.5	1.15~1.6	AVSSXF 0.5 Max	CuSn4
	0-963902-3				CuSn4(GOLD)
	0-963904-1	0.5~1.0	1.4~2.1	AVSSXF 0.85 Max	CuSn4
	0-963904-3				CuSn4(GOLD)
JPT	1-962915-1	0.5~1.0	2.1 Max	AVSSXF 0.85 Max	CuSn4
	1-962915-3				CuSn4(GOLD)
	1-962916-1	1.5~2.5	3.0 Max	AVSS 2.0 Max or FLR 2.5 Max	CuSn4
1-962916-3	CuSn4(GOLD)				
MCP	1-968947-1	2.5~4.0	3.7 Max	AEXF 3.0 Max or FLR 4.0 Max	CuSn4

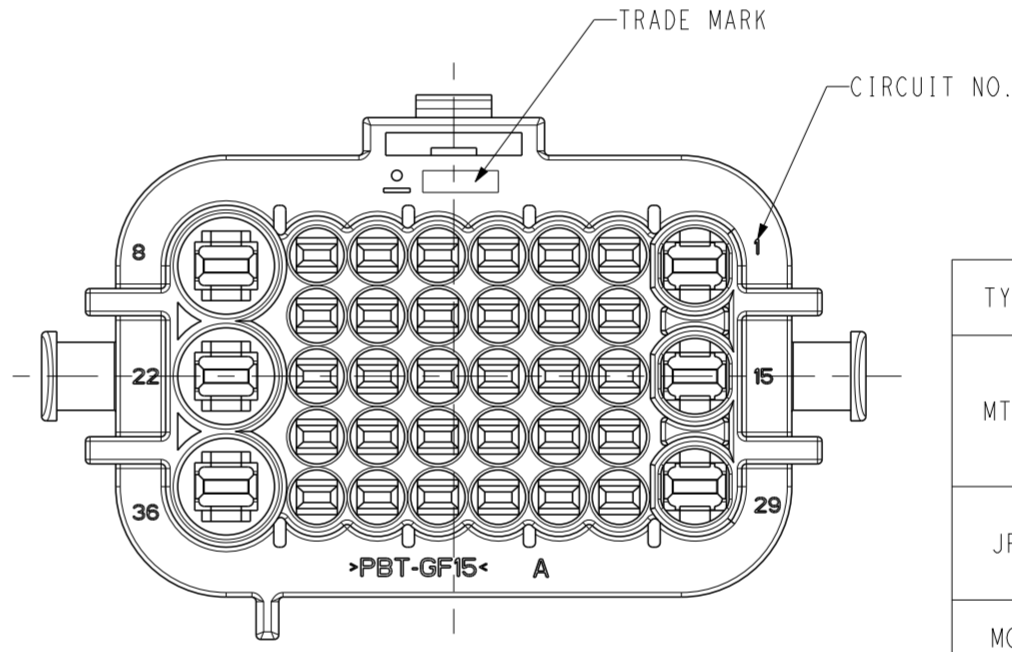
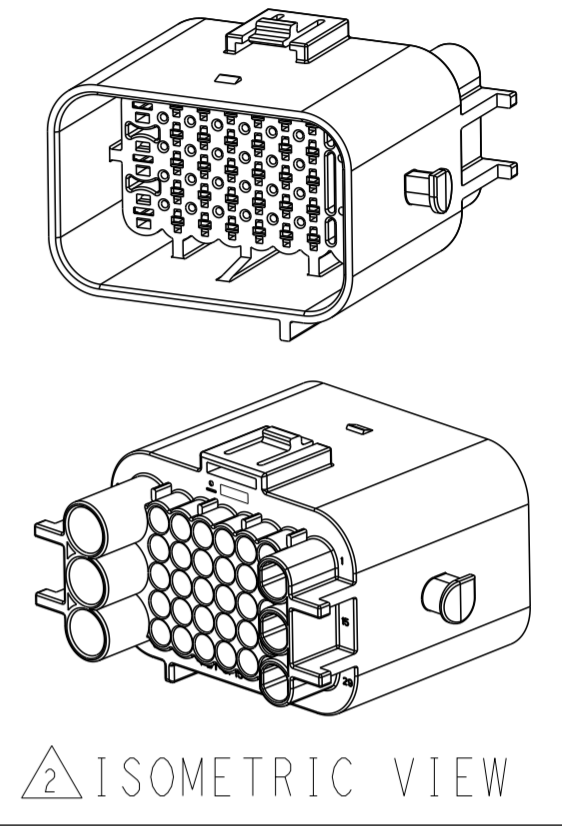

<TABLE 2>

TYPE	WIRE SIZE(mm <sup>2</sup> )	PART NO.	WIRE INSULATION DIAMETER(mm)	COLOR
MTII	0.35~0.5	964971-1	1.2~1.6	RED
	0.5~0.75	963530-1	1.4~1.9	GRAY
	1.0	964972-1	1.9~2.1	YELLOW
		963531-1	CAVITY PLUG	WHITE
JPT	0.35~1.0	828904-2	1.2~2.1	BLUE
	1.5~2.5	828905-1	2.2~3.0	WHITE
MCP	2.5~4.0	828922-1	CAVITY PLUG	NATURAL
		828985-1	3.0~3.7	GREEN
		828986-1	CAVITY PLUG	BROWN

- NOTE
- GENERAL TOLERANCE: ±0.3, ±3°
  - DELIVERY CONDITION
  - APPLIED PLUG P/N: X-1743632-X
  - APPLIED WIRE COVER P/N: X-1743638-X
  - APPLICABLE TAB CONTACT P/N: TABLE 1
  - APPLICABLE WIRE SEAL P/N: TABLE 2

CAP HSG	1743636-2	PBT-GF15	BLACK
DESCRIPTION	P/N	MATERIAL	COLOR

THIS DRAWING IS A CONTROLLED DOCUMENT.

DWN: SJ CHOI  
 CHK: JW JUNG  
 APVD: HG CHO  
 PRODUCT SPEC: 108-61618  
 APPLICATION SPEC

MATERIAL: SEE TABLE

3rd ANGLE PROJECTION

TOLERANCES UNLESS OTHERWISE SPECIFIED:

0 PLC	±
1 PLC	±
2 PLC	±
3 PLC	±
4 PLC	±
ANGLES	±
FINISH	±

WEIGHT: \_\_\_\_\_

CUSTOMER DRAWING

**STE** TE Connectivity

NAME: CAP HSG FOR MTII JPT MCP SEALED 36P CONN'R

SIZE	CAGE CODE	DRAWING NO	RESTRICTED TO
A2	00779	C-1743636	-

SCALE: 2:1 SHEET OF REV: CI