

TPS23753AEVM-004: Evaluation Module for TPS23753A

This user's guide describes the TPS23753AEVM (TPS23753AEVM-004). The TPS23753AEVM-004 contains evaluation and reference circuitry for the TPS23753A. The TPS23753A is an IEEE 802.3-2005 compliant powered-device controller and power supply controller optimized for isolated converter topologies. The TPS23753AEVM-004 is targeted at general, efficient, synchronous rectifier, 10-W flyback converter applications.

Contents

1	Description	2
	1.1 Features	2
	1.2 Applications	2
2	Electrical Specifications	3
3	Schematic	4
4	General Configuration and Description	5
	4.1 Physical Access	5
5	Test Setup	6
6	TPS23753AEVM-004 Typical Performance Data	6
	6.1 3.3-V Efficiency	6
	6.2 5-V DC/DC Efficiency	7
	6.3 12-V DC/DC Efficiency	7
	6.4 TPS23753AEVM-004 Conducted Emissions.....	8
7	EVM Assembly Drawings and Layout Guidelines	8
	7.1 PCB Drawings	8
	7.2 Layout Guidelines	10
	7.3 EMI Containment	11
8	Bill of Materials	12

List of Figures

1	TPS23753AEVM-004 Schematic	4
2	Typical TPS23753AEVM-004 Test Setup	6
3	TPS23753AEVM-004 Efficiency With 3.3-V Output.....	6
4	TPS23753AEVM-003 Efficiency With 5-V Output	7
5	TPS23753AEVM-005 Efficiency With 12-V Output	7
6	TPS23753AEVM-004 Conducted Emissions.....	8
7	Top Side Placement	8
8	Top Side Routing	9
9	Bottom Side Routing	9
10	Bottom Side Placement	10

List of Tables

1	TPS23753AEVM-003, -004, and -005 Electrical and Performance Specifications at T = 25°C	3
2	Connector Functionality	5
3	Test Points	5
4	TPS23753AEVM-003, -004, and -005 Bill of Materials.....	12

1 Description

TPS23753AEVM-004 allows users to evaluate the reference circuitry of the TPS23753A. It contains input and output power connectors and an array of onboard test points for circuit evaluation. TPS23753AEVM-003 (5-V output) and TPS23753AEVM-005 (12-V output) can be configured with simple bill of materials (BOM) changes.

1.1 Features

- Efficient, general market design
 - Simple gate drive, synchronous rectified secondary
 - 10-W output power from power over Ethernet (PoE), 48-V or 24-V adapter and 6-W output power from a 12-V adapter
 - 5-V or 12-V output voltage with simple BOM changes

1.2 Applications

- Voice over Internet protocol – IP telephones
- Wireless LAN – Wireless access points
- Security – Wired IP cameras

2 Electrical Specifications

Table 1. TPS23753AEVM-003, -004, and -005 Electrical and Performance Specifications at T = 25°C

PARAMETER	TEST CONDITIONS	MIN	TYP	MAX	UNIT	
POWER INTERFACE						
Input Voltage	Applied to the power pins of connectors J2, J4, or J6	0		57	V	
Operating Voltage	After start up	30		57	V	
Input UVLO	Rising input voltage			36	V	
	Falling input voltage	30				
Detection voltage	At device terminals	3		10	mA	
Classification voltage	At device terminals	10		23	mA	
Classification current	Rclass = 1270 Ω	1.8		2.4	mA	
Inrush current-limit		90		190	mA	
Operating current-limit		405		495	mA	
DC/DC CONVERTER						
Output voltage	20 V ≤ Vin ≤ 57 V, I _{LOAD} ≤ I _{LOAD} (max) 10.8 V ≤ Vin ≤ 13.2 V, I _{LOAD} ≤ I _{LOAD} (max)	3.3-V output (-004)	3.13	3.3	3.47	V
		5-V output (-003)	4.75	5.0	5.25	
		12-V output (-005)	11.4	12.0	12.6	
Output current	20 V ≤ Vin ≤ 57 V	3.3-V output			3	A
		5-V output			2	
		12-V output			0.9	
	10.8 V ≤ Vin ≤ 13.2 V	3.3-V output			1.8	A
		5-V output			1.2	
		12-V output			0.5	
Output ripple voltage, peak-to-peak	Vin = 44 V, I _{LOAD} = 3 A	3.3-V output		30	mV	
	Vin = 44 V, I _{LOAD} = 2 A	5-V output		40		
	Vin = 44 V, I _{LOAD} = 0.9 A	12-V output		100		
Efficiency, end-to-end	Vin = 44 V, I _{LOAD} = 2 A	3.3-V output		83	%	
	Vin = 44 V, I _{LOAD} = 1.4 A	5-V output		82	%	
	Vin = 44 V, I _{LOAD} = 0.9 A	12-V output		83	%	
Switching frequency		112		138	kHz	

3 Schematic

The TPS23753AEVM-004 schematic follows.

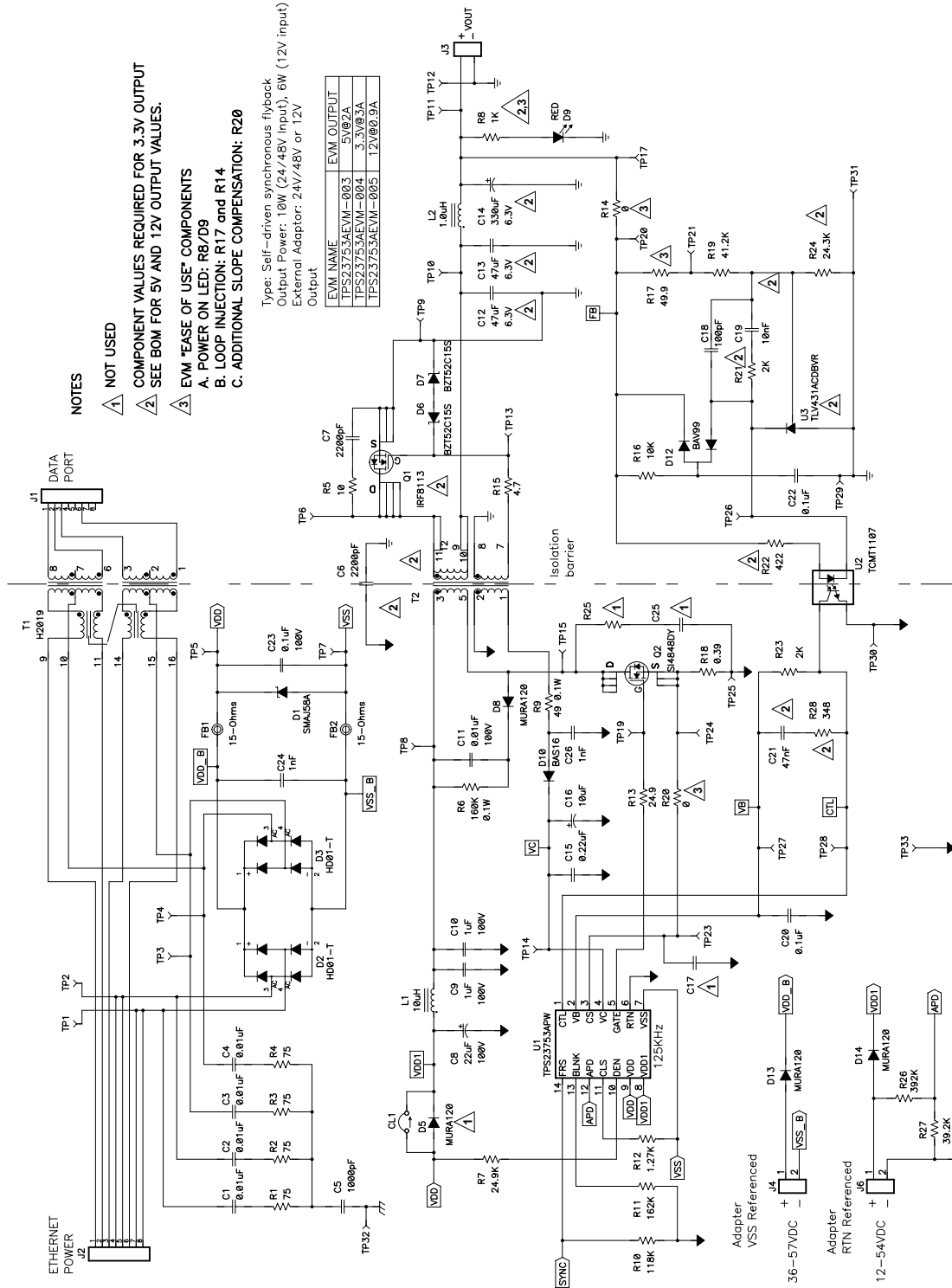

Figure 1. TPS23753AEVM-004 Schematic

4 General Configuration and Description

4.1 Physical Access

Table 2 lists the TPS23753AEVM-004 connector functionality and Table 3 describes the test point availability.

Table 2. Connector Functionality

Connector	Label	Description
J1	DATA PORT	Ethernet data port connector
J2	ETHERNET POWER	Ethernet power input connector. Contains Ethernet transformer and cable terminations
J3	VOUT	Output voltage connector
J4	ADP-VSS	VSS referenced external adapter input connector. J4-1/J4-1 are used with a powered-device adapter input (VSS)
J6	AP-RTN	RTN referenced external adapter input connector. J6-1/J6-2 are used with DC/DC converter adapter input (RTN) and

Table 3. Test Points

Test Point	Color	Label	Description
TP9, TP12, TP29, TP31	BLK	GND	Secondary-side (output) grounds (GND)
TP14	RED	VC	DC/DC converter bias supply
TP15	ORG	DR-P	Drain terminal of the primary-side switching MOSFET
TP7	BLK	VSS	POE input, low side
TP25, TP30, TP33	BLK	RTN	DC/DC converter return
TP20.	ORG	LOOP	Can be used with TP17 for overall feedback loop measurements.
TP21	WHT	I-LOOP	Can be used with TP17 for outer feedback loop measurements.
TP11, TP17	RED	VOUT	DC/DC converter output voltage.
TP10	RED	VOUT1	DC/DC converter output voltage (before LC filter).
TP13	WHT	GTS	Gate drive for the secondary-side synchronous rectifier MOSFET
TP6	WHT	DR-S	Drain terminal of the secondary-side synchronous rectifier MOSFET
TP28	WHT	CTL	Control loop input to the pulse width modulator
TP24	WHT	RCS	DC/DC converter primary-side switching MOSFET current sense (resistor side)
TP23	WHT	CS	DC/DC converter primary-side switching MOSFET current sense input (chip side)
TP27	RED	VB	Bias voltage regulator
TP19	WHT	GATE	Gate drive for the primary-side switching MOSFET
TP8	RED	VPRI	Transformer primary high side.
TP26	WHT	VKAT	Error amplifier (secondary-side) output drive for opto-isolator
TP1	RED	PR78	Pair 7,8
TP4	RED	PR12	Pair 1,2
TP2	ORG	PR45	Pair 4,5
TP3	ORG	PR36	Pair 3,6
D9	RED	POWER ON	Output power indicator

5 Test Setup

Figure 2 shows a typical test setup for TPS23753AEVM-004. Input voltage can be applied as described in Table 2.

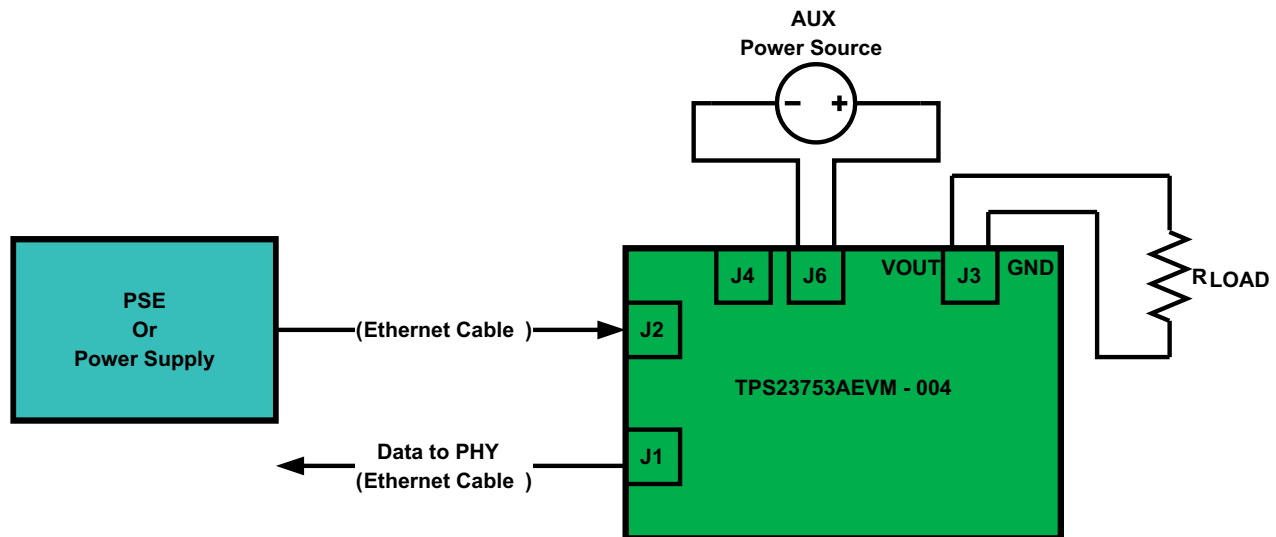

Figure 2. Typical TPS23753AEVM-004 Test Setup

6 TPS23753AEVM-004 Typical Performance Data

6.1 3.3-V Efficiency

Figure 3 illustrates the efficiency at three different input voltage levels: 1) PoE 48V from J2, 2) 48V RTN-based adapter, and 3) 24V RTN-based adapter.

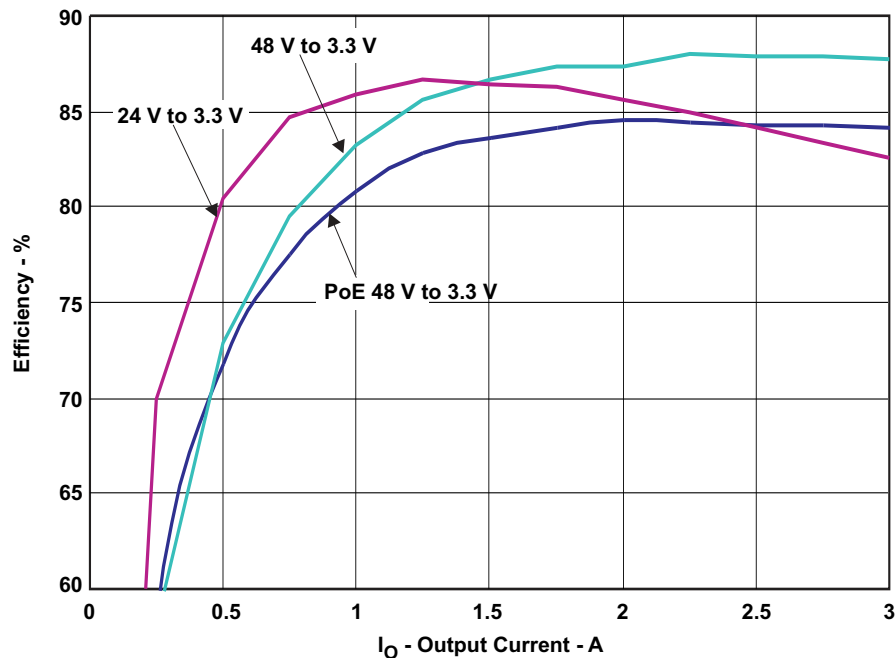

Figure 3. TPS23753AEVM-004 Efficiency With 3.3-V Output

6.2 5-V DC/DC Efficiency

Figure 4 illustrates the efficiency at three different input voltage levels: 1) PoE 48V from J2, 2) 48V RTN-based adapter, and 3) 24V RTN-based adapter.

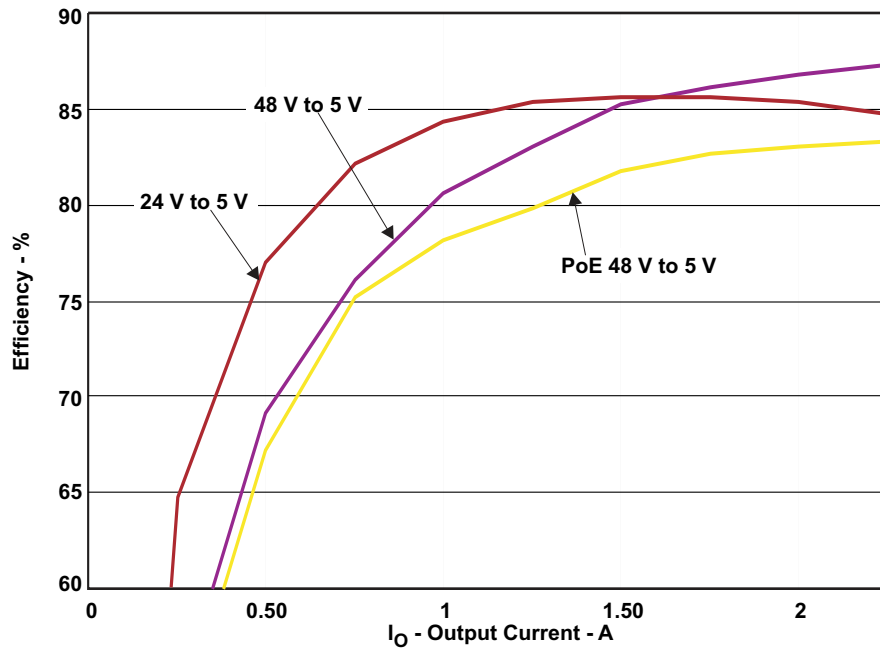

Figure 4. TPS23753AEVM-003 Efficiency With 5-V Output

6.3 12-V DC/DC Efficiency

Figure 5 illustrates the efficiency at three different input voltage levels: 1) PoE 48V from J2, 2) 48V RTN-based adapter, and 3) 24V RTN-based adapter.

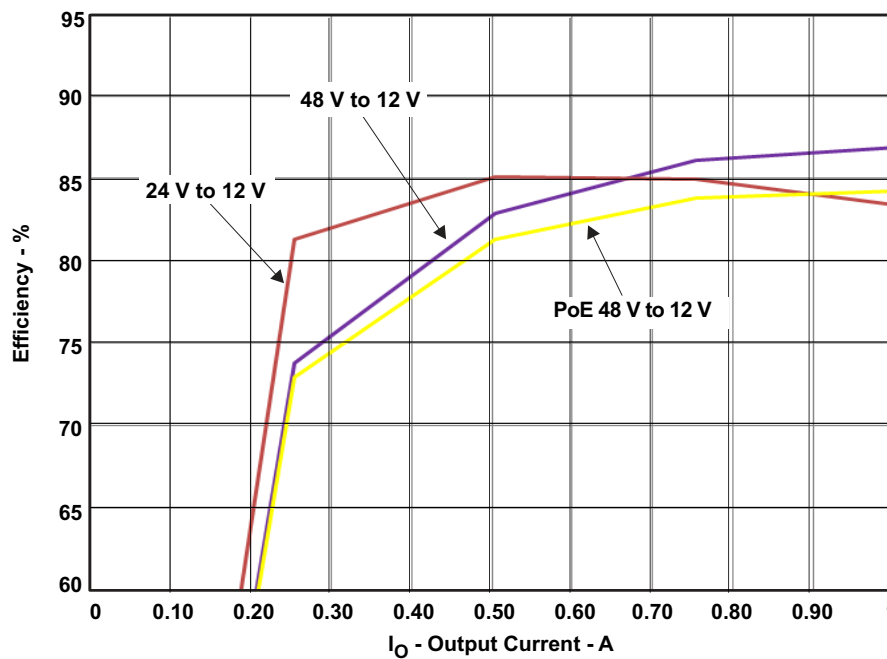

Figure 5. TPS23753AEVM-005 Efficiency With 12-V Output

6.4 TPS23753AEVM-004 Conducted Emissions

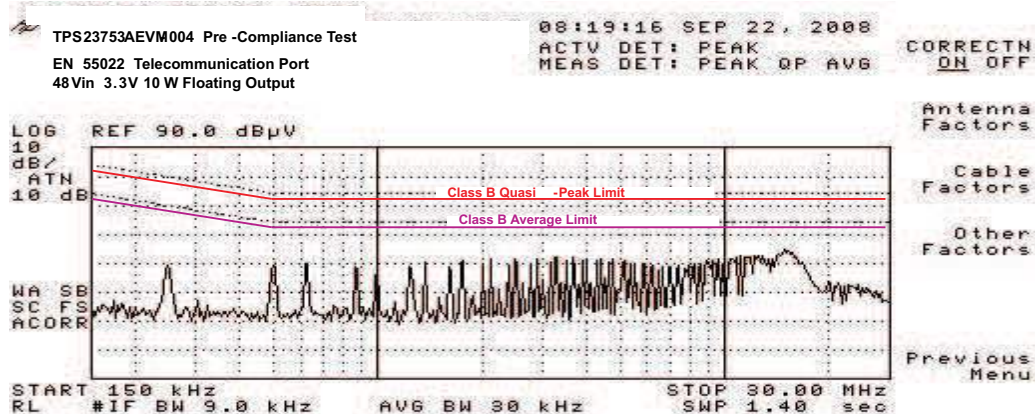

Figure 6. TPS23753AEVM-004 Conducted Emissions

7 EVM Assembly Drawings and Layout Guidelines

7.1 PCB Drawings

Figure 7 shows the component placement and layout.

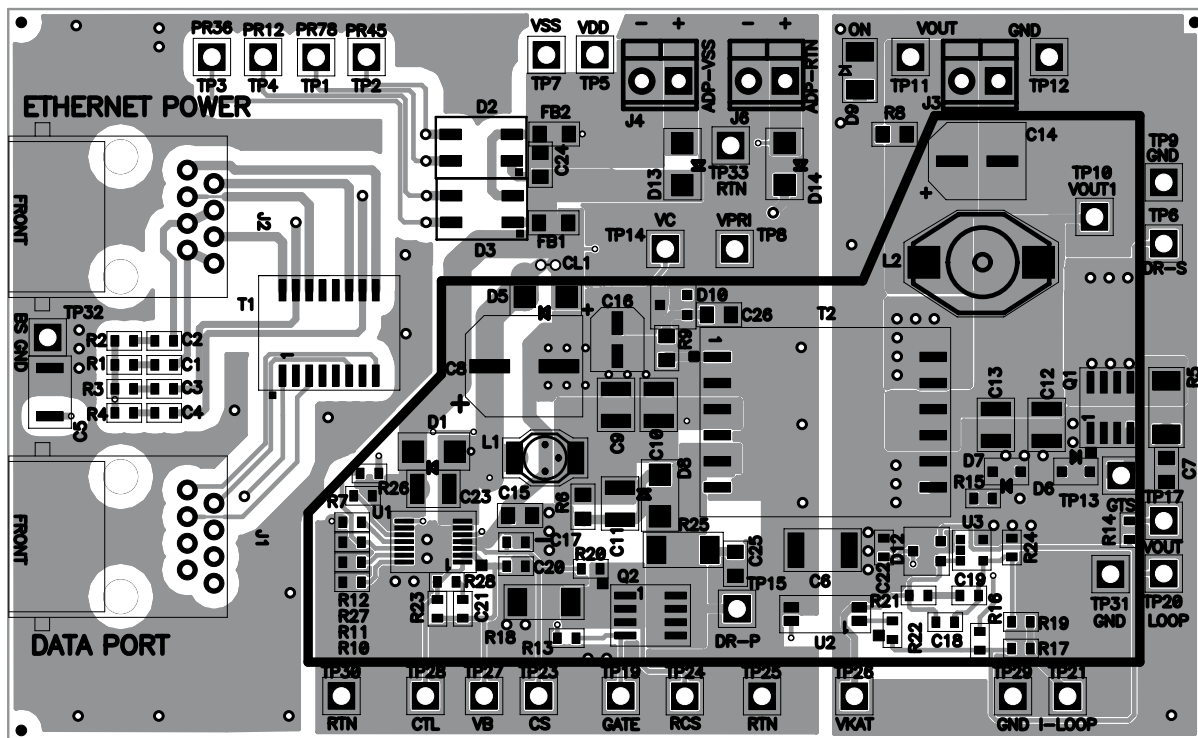

Figure 7. Top Side Placement

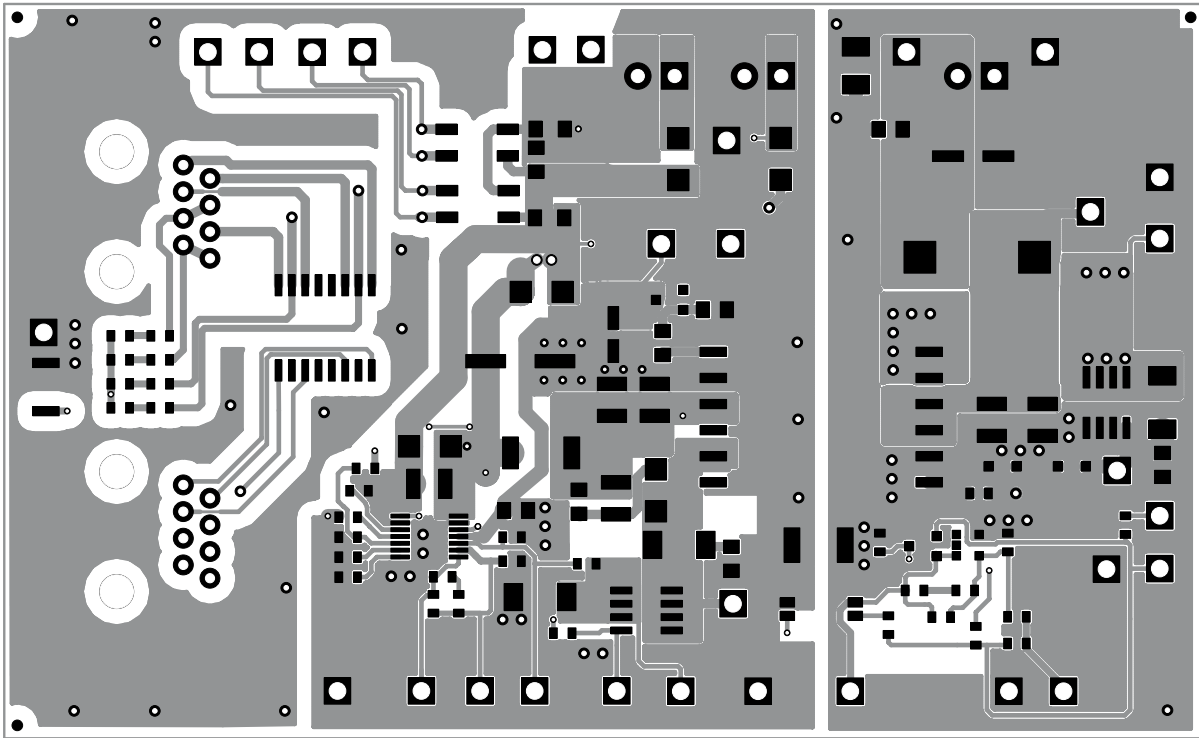

Figure 8. Top Side Routing

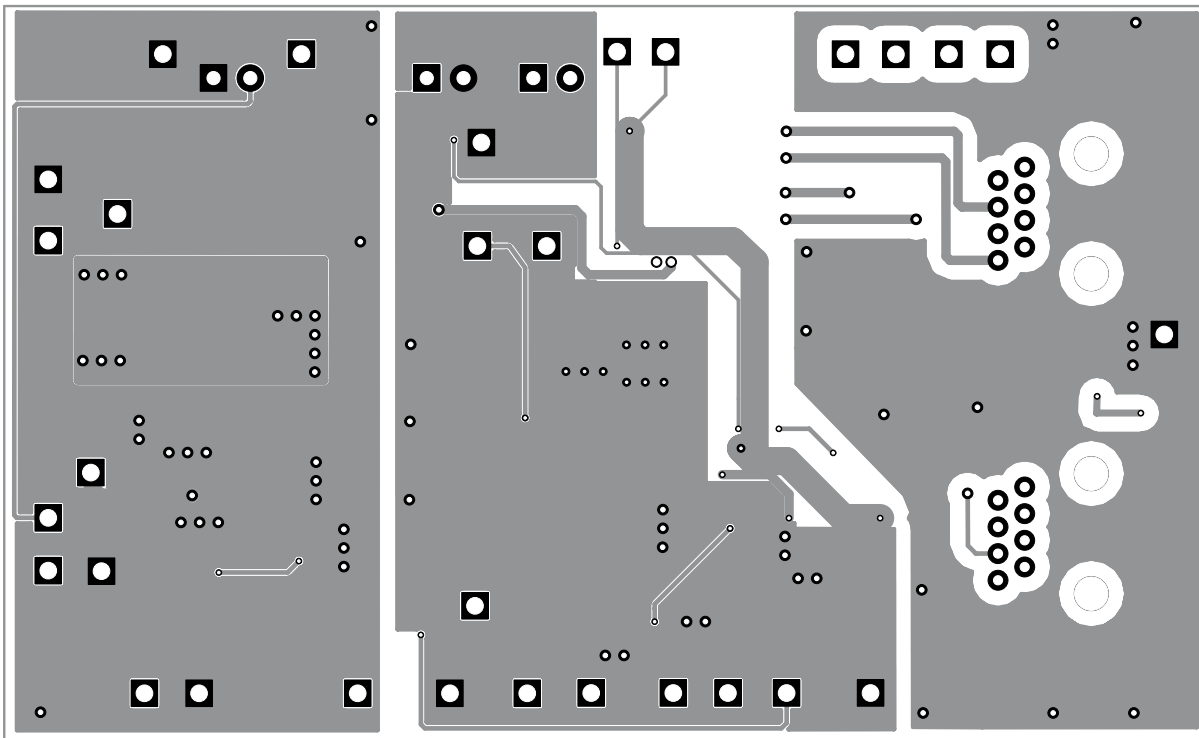

Figure 9. Bottom Side Routing

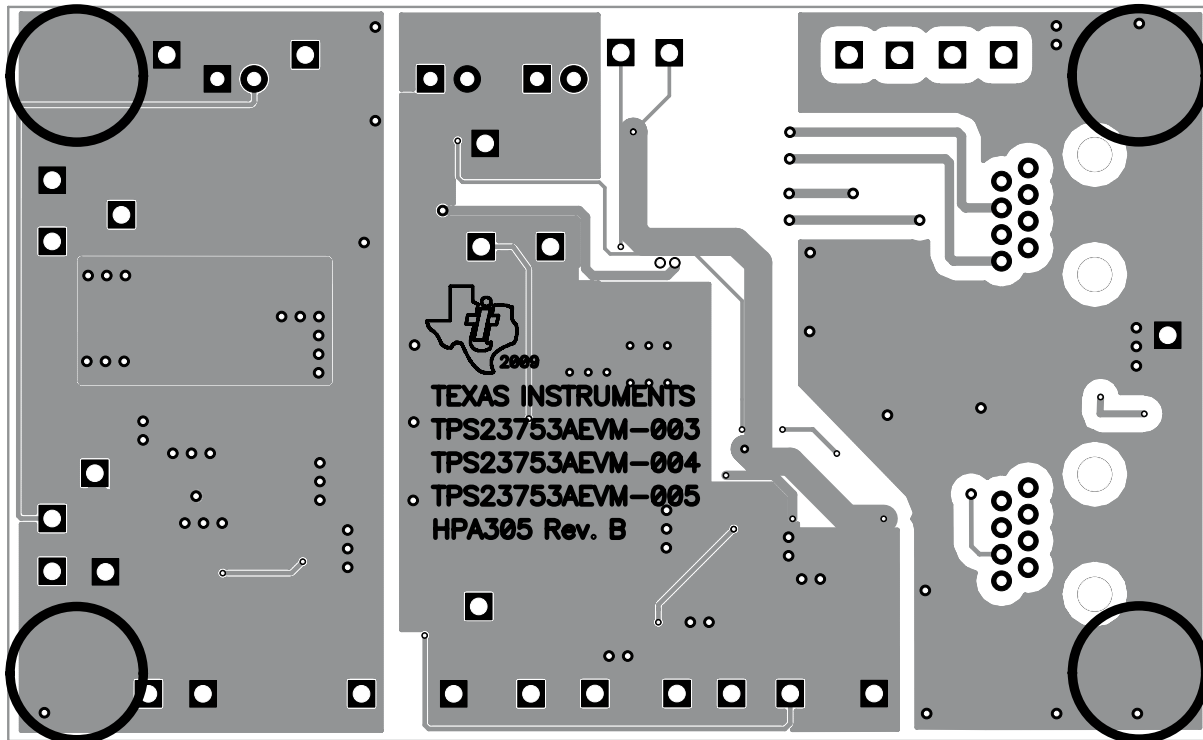

Figure 10. Bottom Side Placement

7.2 Layout Guidelines

The layout of the PoE front end should follow power and EMI/ESD best-practice guidelines. A basic set of recommendations include:

- Parts placement must be driven by power flow in a point-to-point manner; RJ-45, Ethernet transformer, diode bridges, TVS and 0.1- μ F capacitor, and TPS23753A converter input bulk capacitor.
- Make all leads as short as possible with wide power traces and paired signal and return.
- No crossovers of signals from one part of the flow to another are allowed.
- Spacing consistent with safety standards like IEC60950 must be observed between the 48-V input voltage rails and between the input and an isolated converter output.
- Place the TPS23753A over split, local ground planes referenced to V_{SS} for the PoE input and to COM/RTN for the converter. Whereas the PoE side may operate without a ground plane, the converter side must have one. Do not place logic ground and power layers under the Ethernet input or the converter primary side.
- Use large copper fills and traces on SMT power-dissipating devices, and use wide traces or overlay copper fills in the power path.

The DC/DC Converter layout benefits from basic rules such as:

- Pair signals to reduce emissions and noise, especially the paths that carry high-current pulses which include the power semiconductors and magnetics.
- Minimize trace length of high current, power semiconductors, and magnetic components.
- Where possible, use vertical pairing
- Use the ground plane for the switching currents carefully.
- Keep the high-current and high-voltage switching away from low-level sensing circuits including those outside the power supply.
- Proper spacing around the high-voltage sections of the converter

7.3 EMI Containment

- Use compact loops for dv/dt and di/dt circuit paths (power loops and gate drives)
- Use minimal, yet thermally adequate, copper areas for heat sinking of components tied to switching nodes (minimize exposed radiating surface).
- Use copper ground planes (possible stitching) and top-layer copper floods (surround circuitry with ground floods)
- Use a 4-layer PCB, if economically feasible (for better grounding)
- Minimize the amount of copper area associated with input traces (to minimize radiated pickup)
- Hide copper associated with switching nodes under shielded magnetics, where possible
- Heat sink the *quiet side* of components instead of the *switching side*, where possible (like the output side of inductor)
- Use Bob Smith terminations, Bob Smith EFT capacitor, and Bob Smith plane
- Use Bob Smith plane as ground shield on input side of PCB (creating a phantom or literal earth ground)
- Use LC filter at DC/DC input
- Dampen high-frequency ringing on all switching nodes, if present (allow for possible snubbers)
- Control rise times with gate-drive resistors and possibly snubbers
- Switching frequency considerations
- Use of EMI bridge capacitor across isolation boundary (isolated topologies)
- Observe the polarity dot on inductors (embed noisy end)
- Use of ferrite beads on input (allow for possible use of beads or 0-Ω resistors)
- Maintain physical separation between input-related circuitry and power circuitry (use ferrite beads as boundary line)
- Balance efficiency versus acceptable noise margin
- Possible use of common-mode inductors
- Possible use of integrated RJ-45 jacks (shielded with internal transformer and Bob Smith terminations)
- End-product enclosure considerations (shielding)

8 Bill of Materials
Table 4. TPS23753AEVM-003, -004, and -005 Bill of Materials

TPS23753AEVM-X			Ref Des	Value	Description	Size	Part Number	MFR
Outputs (V)								
12	3.3	5						
Count								
X=005	X=004	X=003						
4	4	4	C1, C2, C3, C4	0.01uF	Capacitor, Ceramic, 100V, X7R, 10%	0603	Std	Std
1	1	1	C11	0.01uF	Capacitor, Ceramic, 100V, X7R, 10%	1210	Std	Std
0	2	2	C12, C13	47uF	Capacitor, Ceramic, 6.3-V, X5R, 20%	1210	C3225X5R0J476M	TDK
2	0	0	C12, C13	10uF	Capacitor, Ceramic, 16-V, X5R, 20%	1210	C3225X5R1C106M	TDK
0	1	1	C14	330uF	Capacitor, Aluminum, 6.3V, 20%	0.260 x 0.276 inch	EEVFK0J331XP	Panasonic
1	0	0	C14	68uF	Capacitor, Aluminum, 16V, 20%	0.217 x 0.169	EEVFK1C680P	Panasonic
1	1	1	C15	0.22uF	Capacitor, Ceramic, 25V, X7R, 10%	0805	Std	Std
1	1	1	C16	10uF	Capacitor, Aluminum, 25V, ±20%	0.200 x 0.210 inch	EEVFK1E100R	Panasonic
0	0	0	C17	220pF	Capacitor, Ceramic, 16V, X7R, 10%	0603	Std	Std
0	1	1	C18	100pF	Capacitor, Ceramic, 16V, X7R, 10%	0603	Std	Std
1	0	0	C18	10pF	Capacitor, Ceramic, 16V, X7R, 10%	0603	Std	Std
0	0	1	C19	8.2nF	Capacitor, Ceramic, 16V, X7R, 10%	0603	Std	Std
0	1	0	C19	10nF	Capacitor, Ceramic, 16V, X7R, 10%	0603	Std	Std
1	0	0	C19	6.8nF	Capacitor, Ceramic, 16V, X7R, 10%	0603	Std	Std
2	2	2	C20, C22	0.1uF	Capacitor, Ceramic, 16V, X7R, 10%	0603	Std	Std
0	0	1	C21	22nF	Capacitor, Ceramic, 16V, X7R, 10%	0603	Std	Std
0	1	0	C21	47nF	Capacitor, Ceramic, 16V, X7R, 10%	0603	Std	Std
1	0	0	C21	15nF	Capacitor, Ceramic, 16V, X7R, 10%	0603	Std	Std
1	1	1	C23	0.1uF	Capacitor, Ceramic, 100V, X7R, 10%	1210	Std	Std
2	2	2	C24, C26	1nF	Capacitor, Ceramic, 100V, X7R, 10%	0805	Std	Std
0	0	0	C25	330pF	Capacitor, Ceramic, 200V, X7R, 10%	0805	Std	Std
1	1	1	C5	1000pF	Capacitor, Ceramic, 2kV, X7R 10%	1808	C4520X7R3D102K	TDK
1	1	1	C6	2200pF	Capacitor, Ceramic, 2KV, X7R, 20%	1812	C4532X7R3D222K	TDK
0	1	1	C7	2200pF	Capacitor, Ceramic, 100V, X7R, 10%	0805	Std	Std
1	0	0	C7	1000pF	Capacitor, Ceramic, 100V, X7R, 10%	0805	Std	Std
1	1	1	C8	22uF	Capacitor, Aluminum, 100V, 20%	8x10.2mm	EEVFK2A220P	Panasonic
2	2	2	C9, C10	1uF	Capacitor, Ceramic, 100V, X7R, 10%	1210	Std	Std
1	1	1	CL1	NA	Current Loop, AWG 28, 0.300 inch	0.300 X AWG 28	Std	Std
1	1	1	D1	SMAJ58A	Diode, TVS, 58-V, 1W	SMA	SMAJ58A	Diodes Inc.
1	1	1	D10	BAS16	Diode, Switching, 200mA, 75V, 225mW	SOT-23	BAS16LT1	On Semi
1	1	1	D12	BAV99	Diode, Dual Ultra Fast, Series, 200-mA, 70-V	SOT23	BAV99	Fairchild
2	2	2	D2, D3	HD01-T	Bridge Rectifier, 100V, 0.8A, Glass Passivated, SMD	MINI DIP4	HD01-T	Diodes, Inc
3	3	3	D8, D13, D14	MURA120	Diode, Rectifier, 1A, 200V	SMA	MURA120	On Semi
0	0	0	D5	MURA120	Diode, Rectifier, 1A, 200V	SMA	MURA120	On Semi

Table 4. TPS23753AEVM-003, -004, and -005 Bill of Materials (continued)

TPS23753AEVM-X			Ref Des	Value	Description	Size	Part Number	MFR
Outputs (V)								
12	3.3	5						
Count								
X=005	X=004	X=003						
2	2	2	D6, D7	BZT52C15S	Diode, Zener, 200mW, 15V	SOD-323	BZT52C15S	Diodes, Inc
1	1	1	D9	RED	Diode, LED, RED, 2.0-V, 850-mcd,SM	1210	LTST-C930KRKT	LITE-ON INC
2	2	2	FB1, FB2	15-Ohms	Bead, Ferrite, SMT, 15-Ohms, 1500mA	0805	MMZ2012R150A	TDK
2	2	2	J1, J2	5520252-4	Connector, Jack, Modular, 8 POS	0.705 x 0.820	5520252-4	AMP
3	3	3	J3, J4, J6	ED1514	Terminal Block, 2-pin, 6-A, 3.5mm	0.27 x 0.25	ED1514	OST
1	1	1	L1	10uH	Inductor, SMT, 1.1A, 160milliohm	4.45x6.6mm	DO1608C-103ML_	Coilcraft
1	1	1	L2	1.0uH	Inductor, SMT, 1.0-uH, 6.8-A, 9-milliohm	0.51x0.37	DO3316P-102HCB	Coilcraft
0	1	1	Q1	IRF8113	MOSFET, N-ch, 30-V, 17.2-A, 5.6-milliOhms	SO8	IRF8113	IR
1	0	0	Q1	IRF7855	MOSFET, N-ch, 60-V, 12-A, 9.4-milliOhms	SO8	IRF7855	IR
1	1	1	Q2	SI4848DY	MOSFET, N-ch, 150-V, 3.7-A, 85-milliOhms	SO8	SI4848DY	Vishay Siliconix
4	4	4	R1, R2, R3, R4	75	Resistor, Chip, 1/16W, 5%	0603	Std	Std
1	1	1	R10	118K	Resistor, Chip, 1/16W,1%	0603	Std	Std
1	1	1	R11	162K	Resistor, Chip, 1/16W,1%	0603	Std	Std
1	1	1	R12	1.27K	Resistor, Chip, 1/16W,1%	0603	Std	Std
1	1	1	R13	24.9	Resistor, Chip, 1/16W, 1%	0603	Std	Std
1	1	1	R15	4.7	Resistor, Chip, 1/16W, 5%	0603	Std	Std
1	1	1	R16	10K	Resistor, Chip, 1/16W,1%	0603	Std	Std
1	1	1	R17	49.9	Resistor, Chip, 1/16W,1%	0603	Std	Std
1	1	1	R18	0.39	Resistor, Chip, 1/2W, 1%	2010	Std	Std
0	1	1	R19	41.2K	Resistor, Chip, 1/16W,1%	0603	Std	Std
1	0	0	R19	12.4K	Resistor, Chip, 1/16W,1%	0603	Std	Std
2	2	2	R14, R20	0	Resistor, Chip, 1/16W, 1%	0603	Std	Std
0	0	1	R21	21K	Resistor, Chip, 1/16W, 1%	0603	Std	Std
0	1	0	R21	2K	Resistor, Chip, 1/16W, 1%	0603	Std	Std
1	0	0	R21	15K	Resistor, Chip, 1/16W, 1%	0603	Std	Std
0	0	1	R22	1K	Resistor, Chip, 1/16W,1%	0603	Std	Std
0	1	0	R22	422	Resistor, Chip, 1/16W,1%	0603	Std	Std
1	0	0	R22	2.49K	Resistor, Chip, 1/16W,1%	0603	Std	Std
1	1	1	R23	2K	Resistor, Chip, 1/16W,1%	0603	Std	Std
0	0	1	R24	13.3K	Resistor, Chip, 1/16W,1%	0603	Std	Std
0	1	0	R24	24.3K	Resistor, Chip, 1/16W,1%	0603	Std	Std
1	0	0	R24	3.24K	Resistor, Chip, 1/16W,1%	0603	Std	Std
0	0	0	R25	79	Resistor, Chip, 1/2W, 5%	2010	Std	Std
1	1	1	R26	392K	Resistor, Chip, 1/16W, 1%	0603	Std	Std
1	1	1	R27	39.2K	Resistor, Chip, 1/16W, 1%	0603	Std	Std
0	0	1	R28	249	Resistor, Chip, 1/16W, 1%	0603	Std	Std

Table 4. TPS23753AEVM-003, -004, and -005 Bill of Materials (continued)

TPS23753AEVM-X			Ref Des	Value	Description	Size	Part Number	MFR
Outputs (V)								
12	3.3	5						
Count								
X=005	X=004	X=003						
0	1	0	R28	348	Resistor, Chip, 1/16W, 1%	0603	Std	Std
1	0	0	R28	301	Resistor, Chip, 1/16W, 1%	0603	Std	Std
1	1	1	R5	10	Resistor, Chip, 1/2W, 5%	2010	Std	Std
1	1	1	R6	160K	Resistor, Chip, 1/10W, 5%	0805	Std	Std
1	1	1	R7	24.9K	Resistor, Chip, 1/16W,1%	0603	Std	Std
0	1	1	R8	1K	Resistor, Chip, 1/10-W, 5%	0805	Std	Std
1	0	0	R8	2.87K				
1	1	1	R9	49.9	Resistor, Chip, 1/8W, 1%	0805	Std	Std
1	1	1	T1	H2019	Xfmr, Center-tapped, Voice Over IP	0.500 x 0.370	H2019	Pulse
0	0	1	T2	HA3802-BL or 835-01041FC	Transformer, PoE 13W, Triple Secondary, 150uH, 5V, 2A	0.875 x 0.675	HA3802-BL or 835-01041FC	Coilcraft or E&E Magnetic Products
0	1	0	T2	HA3801-BL or 835-01040FC	Transformer, PoE 13W, Triple Secondary, 165uH, 3.3V, 3A	0.875 x 0.675	HA3801-BL or 835-01040FC	Coilcraft or E&E Magnetic Products
1	0	0	T2	HA3803-BL or 835-01042FC or 750311805	Transformer, PoE 13W, Triple Secondary, 150uH, 12V, 1A	0.875 x 0.675	HA3803-BL or 835-01042FC or 750311805	Coilcraft or E&E Magnetic Products or Wurth
1	1	1	U1	TPS23753APW	IC, IEEE 802.3-2005 Integrated Primary Side Controller	TSSOP14	TPS23753APW	TI
1	1	1	U2	TCMT1107	IC, Photocoupler, 3750VRMS, 80-160% CTR	MF4	TCMT1107	Vishay
0	1	1	U3	TLV431ACDBVR	IC, Shunt Regulator, 1.24-V ref, 6-V, 10-mA, 1%	SOT23-5	TLV431ACDBVR	TI
1	0	0	U3	TL431ACDBVR	IC, Shunt Regulator, 2.49-V ref, 36-V, 10-mA, 1%	SOT23-5	TL431ACDBVR	TI
1	1	1	—	—	PCB, 2.76 In x 4.50 In x 0.062 In	—	HPA305	Any

Revision History

Changes from E Revision (March 2014) to F Revision Page

- Added "or 750311805" to the -005 T2 transformer description in [Table 4](#) 14
-

Revision History

Changes from D Revision (June 2013) to E Revision Page

- Added the Layout Guidelines section 10
 - Added the EMI Containment section 11
-

Revision History

Changes from C Revision (August 2012) to D Revision Page

- Added New row for TL431ACDBVR to the Bill of Materials..... 14
 - Added new row for HPA305 to the Bill of Materials 14
-

STANDARD TERMS AND CONDITIONS FOR EVALUATION MODULES

1. *Delivery:* TI delivers TI evaluation boards, kits, or modules, including any accompanying demonstration software, components, or documentation (collectively, an "EVM" or "EVMs") to the User ("User") in accordance with the terms and conditions set forth herein. Acceptance of the EVM is expressly subject to the following terms and conditions.
 - 1.1 EVMs are intended solely for product or software developers for use in a research and development setting to facilitate feasibility evaluation, experimentation, or scientific analysis of TI semiconductors products. EVMs have no direct function and are not finished products. EVMs shall not be directly or indirectly assembled as a part or subassembly in any finished product. For clarification, any software or software tools provided with the EVM ("Software") shall not be subject to the terms and conditions set forth herein but rather shall be subject to the applicable terms and conditions that accompany such Software
 - 1.2 EVMs are not intended for consumer or household use. EVMs may not be sold, sublicensed, leased, rented, loaned, assigned, or otherwise distributed for commercial purposes by Users, in whole or in part, or used in any finished product or production system.
2. *Limited Warranty and Related Remedies/Disclaimers:*
 - 2.1 These terms and conditions do not apply to Software. The warranty, if any, for Software is covered in the applicable Software License Agreement.
 - 2.2 TI warrants that the TI EVM will conform to TI's published specifications for ninety (90) days after the date TI delivers such EVM to User. Notwithstanding the foregoing, TI shall not be liable for any defects that are caused by neglect, misuse or mistreatment by an entity other than TI, including improper installation or testing, or for any EVMs that have been altered or modified in any way by an entity other than TI. Moreover, TI shall not be liable for any defects that result from User's design, specifications or instructions for such EVMs. Testing and other quality control techniques are used to the extent TI deems necessary or as mandated by government requirements. TI does not test all parameters of each EVM.
 - 2.3 If any EVM fails to conform to the warranty set forth above, TI's sole liability shall be at its option to repair or replace such EVM, or credit User's account for such EVM. TI's liability under this warranty shall be limited to EVMs that are returned during the warranty period to the address designated by TI and that are determined by TI not to conform to such warranty. If TI elects to repair or replace such EVM, TI shall have a reasonable time to repair such EVM or provide replacements. Repaired EVMs shall be warranted for the remainder of the original warranty period. Replaced EVMs shall be warranted for a new full ninety (90) day warranty period.
3. *Regulatory Notices:*
 - 3.1 *United States*
 - 3.1.1 *Notice applicable to EVMs not FCC-Approved:*

This kit is designed to allow product developers to evaluate electronic components, circuitry, or software associated with the kit to determine whether to incorporate such items in a finished product and software developers to write software applications for use with the end product. This kit is not a finished product and when assembled may not be resold or otherwise marketed unless all required FCC equipment authorizations are first obtained. Operation is subject to the condition that this product not cause harmful interference to licensed radio stations and that this product accept harmful interference. Unless the assembled kit is designed to operate under part 15, part 18 or part 95 of this chapter, the operator of the kit must operate under the authority of an FCC license holder or must secure an experimental authorization under part 5 of this chapter.
 - 3.1.2 *For EVMs annotated as FCC – FEDERAL COMMUNICATIONS COMMISSION Part 15 Compliant:*

CAUTION

This device complies with part 15 of the FCC Rules. Operation is subject to the following two conditions: (1) This device may not cause harmful interference, and (2) this device must accept any interference received, including interference that may cause undesired operation.

Changes or modifications not expressly approved by the party responsible for compliance could void the user's authority to operate the equipment.

FCC Interference Statement for Class A EVM devices

NOTE: This equipment has been tested and found to comply with the limits for a Class A digital device, pursuant to part 15 of the FCC Rules. These limits are designed to provide reasonable protection against harmful interference when the equipment is operated in a commercial environment. This equipment generates, uses, and can radiate radio frequency energy and, if not installed and used in accordance with the instruction manual, may cause harmful interference to radio communications. Operation of this equipment in a residential area is likely to cause harmful interference in which case the user will be required to correct the interference at his own expense.

FCC Interference Statement for Class B EVM devices

NOTE: This equipment has been tested and found to comply with the limits for a Class B digital device, pursuant to part 15 of the FCC Rules. These limits are designed to provide reasonable protection against harmful interference in a residential installation. This equipment generates, uses and can radiate radio frequency energy and, if not installed and used in accordance with the instructions, may cause harmful interference to radio communications. However, there is no guarantee that interference will not occur in a particular installation. If this equipment does cause harmful interference to radio or television reception, which can be determined by turning the equipment off and on, the user is encouraged to try to correct the interference by one or more of the following measures:

- Reorient or relocate the receiving antenna.
- Increase the separation between the equipment and receiver.
- Connect the equipment into an outlet on a circuit different from that to which the receiver is connected.
- Consult the dealer or an experienced radio/TV technician for help.

3.2 Canada

3.2.1 For EVMs issued with an Industry Canada Certificate of Conformance to RSS-210

Concerning EVMs Including Radio Transmitters:

This device complies with Industry Canada license-exempt RSS standard(s). Operation is subject to the following two conditions: (1) this device may not cause interference, and (2) this device must accept any interference, including interference that may cause undesired operation of the device.

Concernant les EVMs avec appareils radio:

Le présent appareil est conforme aux CNR d'Industrie Canada applicables aux appareils radio exempts de licence. L'exploitation est autorisée aux deux conditions suivantes: (1) l'appareil ne doit pas produire de brouillage, et (2) l'utilisateur de l'appareil doit accepter tout brouillage radioélectrique subi, même si le brouillage est susceptible d'en compromettre le fonctionnement.

Concerning EVMs Including Detachable Antennas:

Under Industry Canada regulations, this radio transmitter may only operate using an antenna of a type and maximum (or lesser) gain approved for the transmitter by Industry Canada. To reduce potential radio interference to other users, the antenna type and its gain should be so chosen that the equivalent isotropically radiated power (e.i.r.p.) is not more than that necessary for successful communication. This radio transmitter has been approved by Industry Canada to operate with the antenna types listed in the user guide with the maximum permissible gain and required antenna impedance for each antenna type indicated. Antenna types not included in this list, having a gain greater than the maximum gain indicated for that type, are strictly prohibited for use with this device.

Concernant les EVMs avec antennes détachables

Conformément à la réglementation d'Industrie Canada, le présent émetteur radio peut fonctionner avec une antenne d'un type et d'un gain maximal (ou inférieur) approuvé pour l'émetteur par Industrie Canada. Dans le but de réduire les risques de brouillage radioélectrique à l'intention des autres utilisateurs, il faut choisir le type d'antenne et son gain de sorte que la puissance isotrope rayonnée équivalente (p.i.r.e.) ne dépasse pas l'intensité nécessaire à l'établissement d'une communication satisfaisante. Le présent émetteur radio a été approuvé par Industrie Canada pour fonctionner avec les types d'antenne énumérés dans le manuel d'usage et ayant un gain admissible maximal et l'impédance requise pour chaque type d'antenne. Les types d'antenne non inclus dans cette liste, ou dont le gain est supérieur au gain maximal indiqué, sont strictement interdits pour l'exploitation de l'émetteur.

3.3 Japan

3.3.1 *Notice for EVMs delivered in Japan:* Please see http://www.tij.co.jp/lstds/ti_ja/general/eStore/notice_01.page 日本国内に輸入される評価用キット、ボードについては、次のところをご覧ください。
http://www.tij.co.jp/lstds/ti_ja/general/eStore/notice_01.page

3.3.2 *Notice for Users of EVMs Considered "Radio Frequency Products" in Japan:* EVMs entering Japan may not be certified by TI as conforming to Technical Regulations of Radio Law of Japan.

If User uses EVMs in Japan, not certified to Technical Regulations of Radio Law of Japan, User is required by Radio Law of Japan to follow the instructions below with respect to EVMs:

1. Use EVMs in a shielded room or any other test facility as defined in the notification #173 issued by Ministry of Internal Affairs and Communications on March 28, 2006, based on Sub-section 1.1 of Article 6 of the Ministry's Rule for Enforcement of Radio Law of Japan,
2. Use EVMs only after User obtains the license of Test Radio Station as provided in Radio Law of Japan with respect to EVMs, or
3. Use of EVMs only after User obtains the Technical Regulations Conformity Certification as provided in Radio Law of Japan with respect to EVMs. Also, do not transfer EVMs, unless User gives the same notice above to the transferee. Please note that if User does not follow the instructions above, User will be subject to penalties of Radio Law of Japan.

【無線電波を送信する製品の開発キットをお使いになる際の注意事項】 開発キットの中には技術基準適合証明を受けていないものがあります。技術適合証明を受けていないものご使用に際しては、電波法遵守のため、以下のいずれかの措置を取っていただく必要がありますのでご注意ください。

1. 電波法施行規則第6条第1項第1号に基づく平成18年3月28日総務省告示第173号で定められた電波暗室等の試験設備でご使用いただく。
2. 実験局の免許を取得後ご使用いただく。
3. 技術基準適合証明を取得後ご使用いただく。

なお、本製品は、上記の「ご使用にあたっての注意」を譲渡先、移転先に通知しない限り、譲渡、移転できないものとします。

上記を遵守頂けない場合は、電波法の罰則が適用される可能性があることをご留意ください。日本テキサス・インスツルメンツ株式会社
東京都新宿区西新宿 6 丁目 2 4 番 1 号
西新宿三井ビル

3.3.3 *Notice for EVMs for Power Line Communication:* Please see http://www.tij.co.jp/llds/ti_ja/general/eStore/notice_02.page
電力線搬送波通信についての開発キットをお使いになる際の注意事項については、次のところをご覧ください。http://www.tij.co.jp/llds/ti_ja/general/eStore/notice_02.page

4 *EVM Use Restrictions and Warnings:*

4.1 EVMS ARE NOT FOR USE IN FUNCTIONAL SAFETY AND/OR SAFETY CRITICAL EVALUATIONS, INCLUDING BUT NOT LIMITED TO EVALUATIONS OF LIFE SUPPORT APPLICATIONS.

4.2 User must read and apply the user guide and other available documentation provided by TI regarding the EVM prior to handling or using the EVM, including without limitation any warning or restriction notices. The notices contain important safety information related to, for example, temperatures and voltages.

4.3 *Safety-Related Warnings and Restrictions:*

4.3.1 User shall operate the EVM within TI's recommended specifications and environmental considerations stated in the user guide, other available documentation provided by TI, and any other applicable requirements and employ reasonable and customary safeguards. Exceeding the specified performance ratings and specifications (including but not limited to input and output voltage, current, power, and environmental ranges) for the EVM may cause personal injury or death, or property damage. If there are questions concerning performance ratings and specifications, User should contact a TI field representative prior to connecting interface electronics including input power and intended loads. Any loads applied outside of the specified output range may also result in unintended and/or inaccurate operation and/or possible permanent damage to the EVM and/or interface electronics. Please consult the EVM user guide prior to connecting any load to the EVM output. If there is uncertainty as to the load specification, please contact a TI field representative. During normal operation, even with the inputs and outputs kept within the specified allowable ranges, some circuit components may have elevated case temperatures. These components include but are not limited to linear regulators, switching transistors, pass transistors, current sense resistors, and heat sinks, which can be identified using the information in the associated documentation. When working with the EVM, please be aware that the EVM may become very warm.

4.3.2 EVMs are intended solely for use by technically qualified, professional electronics experts who are familiar with the dangers and application risks associated with handling electrical mechanical components, systems, and subsystems. User assumes all responsibility and liability for proper and safe handling and use of the EVM by User or its employees, affiliates, contractors or designees. User assumes all responsibility and liability to ensure that any interfaces (electronic and/or mechanical) between the EVM and any human body are designed with suitable isolation and means to safely limit accessible leakage currents to minimize the risk of electrical shock hazard. User assumes all responsibility and liability for any improper or unsafe handling or use of the EVM by User or its employees, affiliates, contractors or designees.

4.4 User assumes all responsibility and liability to determine whether the EVM is subject to any applicable international, federal, state, or local laws and regulations related to User's handling and use of the EVM and, if applicable, User assumes all responsibility and liability for compliance in all respects with such laws and regulations. User assumes all responsibility and liability for proper disposal and recycling of the EVM consistent with all applicable international, federal, state, and local requirements.

5. *Accuracy of Information:* To the extent TI provides information on the availability and function of EVMs, TI attempts to be as accurate as possible. However, TI does not warrant the accuracy of EVM descriptions, EVM availability or other information on its websites as accurate, complete, reliable, current, or error-free.

6. *Disclaimers:*
- 6.1 EXCEPT AS SET FORTH ABOVE, EVMS AND ANY WRITTEN DESIGN MATERIALS PROVIDED WITH THE EVM (AND THE DESIGN OF THE EVM ITSELF) ARE PROVIDED "AS IS" AND "WITH ALL FAULTS." TI DISCLAIMS ALL OTHER WARRANTIES, EXPRESS OR IMPLIED, REGARDING SUCH ITEMS, INCLUDING BUT NOT LIMITED TO ANY IMPLIED WARRANTIES OF MERCHANTABILITY OR FITNESS FOR A PARTICULAR PURPOSE OR NON-INFRINGEMENT OF ANY THIRD PARTY PATENTS, COPYRIGHTS, TRADE SECRETS OR OTHER INTELLECTUAL PROPERTY RIGHTS.
- 6.2 EXCEPT FOR THE LIMITED RIGHT TO USE THE EVM SET FORTH HEREIN, NOTHING IN THESE TERMS AND CONDITIONS SHALL BE CONSTRUED AS GRANTING OR CONFERRING ANY RIGHTS BY LICENSE, PATENT, OR ANY OTHER INDUSTRIAL OR INTELLECTUAL PROPERTY RIGHT OF TI, ITS SUPPLIERS/LICENSORS OR ANY OTHER THIRD PARTY, TO USE THE EVM IN ANY FINISHED END-USER OR READY-TO-USE FINAL PRODUCT, OR FOR ANY INVENTION, DISCOVERY OR IMPROVEMENT MADE, CONCEIVED OR ACQUIRED PRIOR TO OR AFTER DELIVERY OF THE EVM.
7. *USER'S INDEMNITY OBLIGATIONS AND REPRESENTATIONS.* USER WILL DEFEND, INDEMNIFY AND HOLD TI, ITS LICENSORS AND THEIR REPRESENTATIVES HARMLESS FROM AND AGAINST ANY AND ALL CLAIMS, DAMAGES, LOSSES, EXPENSES, COSTS AND LIABILITIES (COLLECTIVELY, "CLAIMS") ARISING OUT OF OR IN CONNECTION WITH ANY HANDLING OR USE OF THE EVM THAT IS NOT IN ACCORDANCE WITH THESE TERMS AND CONDITIONS. THIS OBLIGATION SHALL APPLY WHETHER CLAIMS ARISE UNDER STATUTE, REGULATION, OR THE LAW OF TORT, CONTRACT OR ANY OTHER LEGAL THEORY, AND EVEN IF THE EVM FAILS TO PERFORM AS DESCRIBED OR EXPECTED.
8. *Limitations on Damages and Liability:*
- 8.1 *General Limitations.* IN NO EVENT SHALL TI BE LIABLE FOR ANY SPECIAL, COLLATERAL, INDIRECT, PUNITIVE, INCIDENTAL, CONSEQUENTIAL, OR EXEMPLARY DAMAGES IN CONNECTION WITH OR ARISING OUT OF THESE TERMS AND CONDITIONS OR THE USE OF THE EVMS PROVIDED HEREUNDER, REGARDLESS OF WHETHER TI HAS BEEN ADVISED OF THE POSSIBILITY OF SUCH DAMAGES. EXCLUDED DAMAGES INCLUDE, BUT ARE NOT LIMITED TO, COST OF REMOVAL OR REINSTALLATION, ANCILLARY COSTS TO THE PROCUREMENT OF SUBSTITUTE GOODS OR SERVICES, RETESTING, OUTSIDE COMPUTER TIME, LABOR COSTS, LOSS OF GOODWILL, LOSS OF PROFITS, LOSS OF SAVINGS, LOSS OF USE, LOSS OF DATA, OR BUSINESS INTERRUPTION. NO CLAIM, SUIT OR ACTION SHALL BE BROUGHT AGAINST TI MORE THAN ONE YEAR AFTER THE RELATED CAUSE OF ACTION HAS OCCURRED.
- 8.2 *Specific Limitations.* IN NO EVENT SHALL TI'S AGGREGATE LIABILITY FROM ANY WARRANTY OR OTHER OBLIGATION ARISING OUT OF OR IN CONNECTION WITH THESE TERMS AND CONDITIONS, OR ANY USE OF ANY TI EVM PROVIDED HEREUNDER, EXCEED THE TOTAL AMOUNT PAID TO TI FOR THE PARTICULAR UNITS SOLD UNDER THESE TERMS AND CONDITIONS WITH RESPECT TO WHICH LOSSES OR DAMAGES ARE CLAIMED. THE EXISTENCE OF MORE THAN ONE CLAIM AGAINST THE PARTICULAR UNITS SOLD TO USER UNDER THESE TERMS AND CONDITIONS SHALL NOT ENLARGE OR EXTEND THIS LIMIT.
9. *Return Policy.* Except as otherwise provided, TI does not offer any refunds, returns, or exchanges. Furthermore, no return of EVM(s) will be accepted if the package has been opened and no return of the EVM(s) will be accepted if they are damaged or otherwise not in a resalable condition. If User feels it has been incorrectly charged for the EVM(s) it ordered or that delivery violates the applicable order, User should contact TI. All refunds will be made in full within thirty (30) working days from the return of the components(s), excluding any postage or packaging costs.
10. *Governing Law:* These terms and conditions shall be governed by and interpreted in accordance with the laws of the State of Texas, without reference to conflict-of-laws principles. User agrees that non-exclusive jurisdiction for any dispute arising out of or relating to these terms and conditions lies within courts located in the State of Texas and consents to venue in Dallas County, Texas. Notwithstanding the foregoing, any judgment may be enforced in any United States or foreign court, and TI may seek injunctive relief in any United States or foreign court.

Mailing Address: Texas Instruments, Post Office Box 655303, Dallas, Texas 75265
Copyright © 2015, Texas Instruments Incorporated

IMPORTANT NOTICE

Texas Instruments Incorporated and its subsidiaries (TI) reserve the right to make corrections, enhancements, improvements and other changes to its semiconductor products and services per JESD46, latest issue, and to discontinue any product or service per JESD48, latest issue. Buyers should obtain the latest relevant information before placing orders and should verify that such information is current and complete. All semiconductor products (also referred to herein as "components") are sold subject to TI's terms and conditions of sale supplied at the time of order acknowledgment.

TI warrants performance of its components to the specifications applicable at the time of sale, in accordance with the warranty in TI's terms and conditions of sale of semiconductor products. Testing and other quality control techniques are used to the extent TI deems necessary to support this warranty. Except where mandated by applicable law, testing of all parameters of each component is not necessarily performed.

TI assumes no liability for applications assistance or the design of Buyers' products. Buyers are responsible for their products and applications using TI components. To minimize the risks associated with Buyers' products and applications, Buyers should provide adequate design and operating safeguards.

TI does not warrant or represent that any license, either express or implied, is granted under any patent right, copyright, mask work right, or other intellectual property right relating to any combination, machine, or process in which TI components or services are used. Information published by TI regarding third-party products or services does not constitute a license to use such products or services or a warranty or endorsement thereof. Use of such information may require a license from a third party under the patents or other intellectual property of the third party, or a license from TI under the patents or other intellectual property of TI.

Reproduction of significant portions of TI information in TI data books or data sheets is permissible only if reproduction is without alteration and is accompanied by all associated warranties, conditions, limitations, and notices. TI is not responsible or liable for such altered documentation. Information of third parties may be subject to additional restrictions.

Resale of TI components or services with statements different from or beyond the parameters stated by TI for that component or service voids all express and any implied warranties for the associated TI component or service and is an unfair and deceptive business practice. TI is not responsible or liable for any such statements.

Buyer acknowledges and agrees that it is solely responsible for compliance with all legal, regulatory and safety-related requirements concerning its products, and any use of TI components in its applications, notwithstanding any applications-related information or support that may be provided by TI. Buyer represents and agrees that it has all the necessary expertise to create and implement safeguards which anticipate dangerous consequences of failures, monitor failures and their consequences, lessen the likelihood of failures that might cause harm and take appropriate remedial actions. Buyer will fully indemnify TI and its representatives against any damages arising out of the use of any TI components in safety-critical applications.

In some cases, TI components may be promoted specifically to facilitate safety-related applications. With such components, TI's goal is to help enable customers to design and create their own end-product solutions that meet applicable functional safety standards and requirements. Nonetheless, such components are subject to these terms.

No TI components are authorized for use in FDA Class III (or similar life-critical medical equipment) unless authorized officers of the parties have executed a special agreement specifically governing such use.

Only those TI components which TI has specifically designated as military grade or "enhanced plastic" are designed and intended for use in military/aerospace applications or environments. Buyer acknowledges and agrees that any military or aerospace use of TI components which have **not** been so designated is solely at the Buyer's risk, and that Buyer is solely responsible for compliance with all legal and regulatory requirements in connection with such use.

TI has specifically designated certain components as meeting ISO/TS16949 requirements, mainly for automotive use. In any case of use of non-designated products, TI will not be responsible for any failure to meet ISO/TS16949.

Products

Audio	www.ti.com/audio
Amplifiers	amplifier.ti.com
Data Converters	dataconverter.ti.com
DLP® Products	www.dlp.com
DSP	dsp.ti.com
Clocks and Timers	www.ti.com/clocks
Interface	interface.ti.com
Logic	logic.ti.com
Power Mgmt	power.ti.com
Microcontrollers	microcontroller.ti.com
RFID	www.ti-rfid.com
OMAP Applications Processors	www.ti.com/omap
Wireless Connectivity	www.ti.com/wirelessconnectivity

Applications

Automotive and Transportation	www.ti.com/automotive
Communications and Telecom	www.ti.com/communications
Computers and Peripherals	www.ti.com/computers
Consumer Electronics	www.ti.com/consumer-apps
Energy and Lighting	www.ti.com/energy
Industrial	www.ti.com/industrial
Medical	www.ti.com/medical
Security	www.ti.com/security
Space, Avionics and Defense	www.ti.com/space-avionics-defense
Video and Imaging	www.ti.com/video

TI E2E Community

e2e.ti.com