

PRODUCT NUMBER
SEE PART NO. TABLE

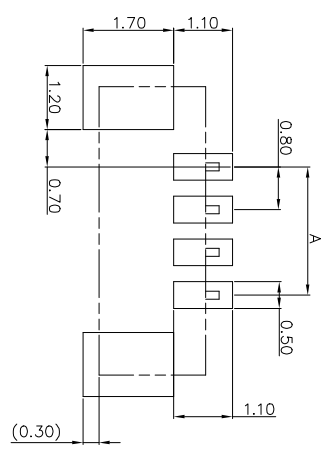
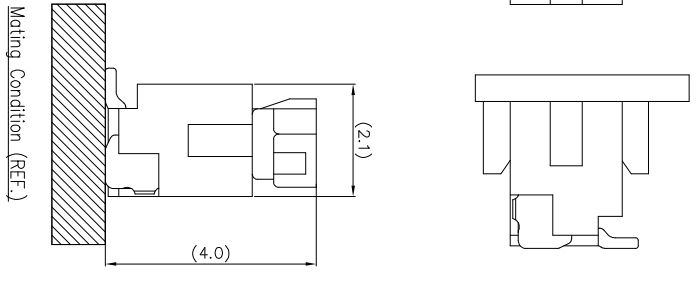
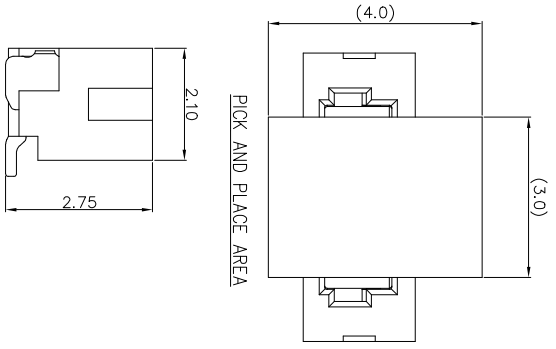
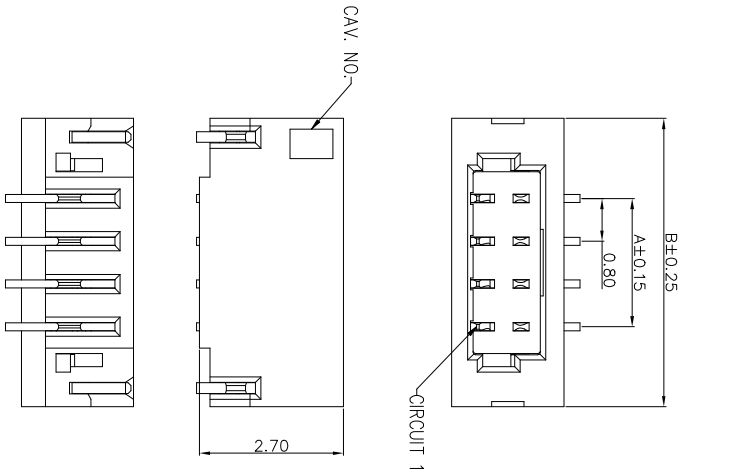

TOLERANCE: ±0.05
RECOMMENDED P.C.B. Layout
TOP VIEW

NOTES:

1. MATERIAL: INSULATION(HALOGEN FREE): THERMOPLASTIC HIGH TEMP.U194V-0,LOW WIRE COMPATIBLE CONTACT: COPPER ALLOY, 1=0.15
2. MATE WITH RECEPTACLE: AFCI 10145492
3. THE INSULATION CAN WITHSTAND IR REFLOW 260°C FOR 10 SECONDS
4. PRODUCT SPEC: GS-12-1444
5. PACKAGING SPEC: GS-14-2616
6. ORDERING CODE: 10144042-XX X X X LF

NO. OF PINS
02~20 PIN
INSULATION COLOR

PACKAGE
1: TAPE & REEL
2: ESD TAPE & REEL

CONTACT FINISH
1: MATTE-TIN PLATED OVER NICKEL
2: GOLD FLASH OVER NICKEL

mat'l. code

ltr	ecm no	dr	date	surface	tolerance	projection
A	Rev Release	Tony	2017-05-22	ISO 1302	ISO 406	ISO 1101
B	ELX-N-33468	Jason	2019-05-14	tolerances unless otherwise specified	.XX±.15	mm
C	ELX-N-35144	Jason	2019-10-22	dr	.XXX±.08	scale 1:1

PIN	A	B	PIN	A	B
02	0.80	3.80	12	8.80	11.80
03	1.60	4.60	13	9.60	12.60
04	2.40	5.40	14	10.40	13.40
05	3.20	6.20	15	11.20	14.20
06	4.00	7.00	16	12.00	15.00
07	4.80	7.80	17	12.80	15.80
08	5.60	8.60	18	13.60	16.60
09	6.40	9.40	19	14.40	17.40
10	7.20	10.20	20	15.20	18.20
11	8.00	11.00			

product family
MINITEK

title
0.8mm Pitch VT Header SMT

dwg no
10144042



type Product Customer Drawing

sheet index	revision	sheet
1	C	1