

REVISIONS					
REV	ECO	DESCRIPTION	DATE	BY	APPR
A1	-	RELEASE	30MAR2017	JAH	
A2	C1298S	UPDATE PLATING	14/SEP/20	SULLEN	TOMMY

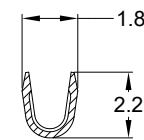

SECTION A-A

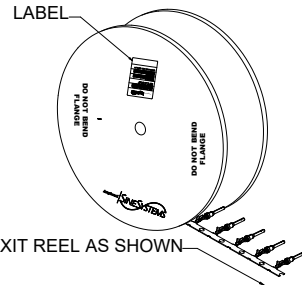
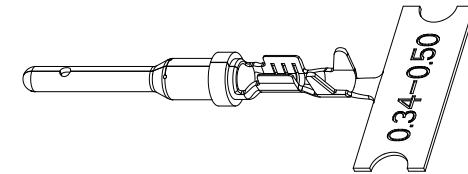
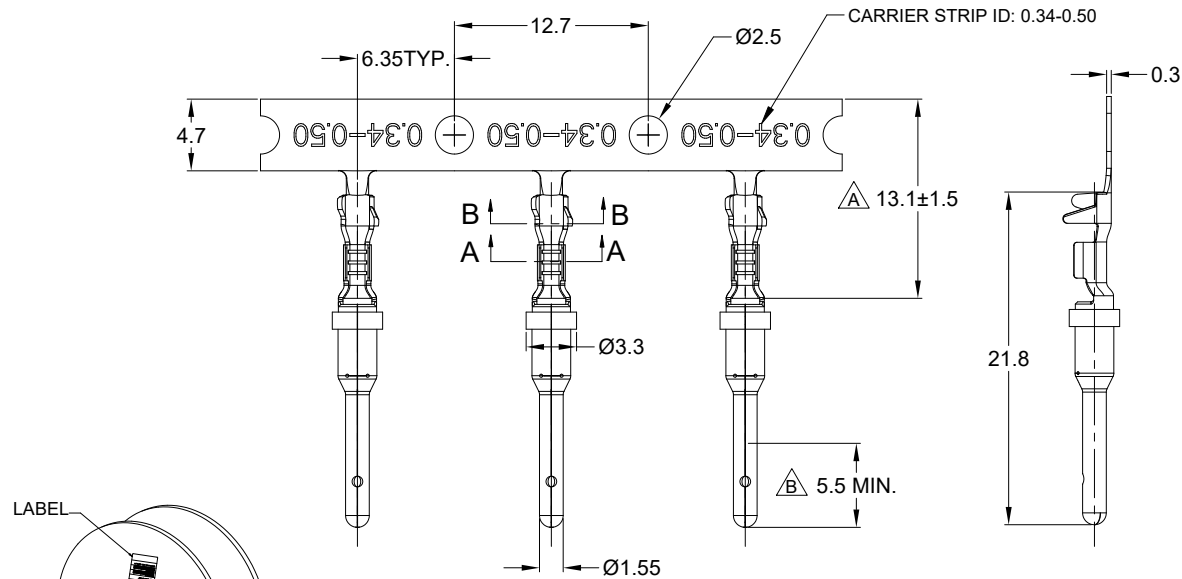
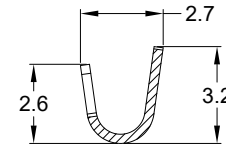

SECTION B-B

NOTES: UNLESS OTHERWISE SPECIFIED

- MATERIAL: COPPER ALLOY.
- PLATING: SEE PART NUMBER CHART
- CONTACT SIZE: 16.
- SPECIFICATIONS:
 - CURRENT RATING: 13 AMPS
 - CONTACT MILLIVOLT DROP: 100 MILLIVOLT DROP @ 13 AMP TEST CURRENT.
 - RoHS COMPLIANT.
- RECOMMENDED WIRE RANGE: 20 - 22 AWG (0.5 - 0.35mm²)
RECOMMENDED INSUL O.D: 1.31 - 1.50MM (0.051 - 0.059INCH)
- PACKAGE: 4000 PCS/REEL
- ALL DIMENSIONS ARE FOR REFERENCE USE ONLY.

PART NUMBER CHART		
PLATING	PART NUMBER	PLATING DESCRIPTION
NICKEL	AT60-16-0822	SELECTIVE TIN OVER NICKEL OVERALL IN Δ ZONE
GOLD	AT60-16-0844	SELECTIVE GOLD FLASH OVER NICKEL OVERALL IN ∇ ZONE OR ENTIRE CONTACT
TIN	AT60-16-0877	TIN OVER NICKEL OVERALL

SEE PART NUMBER CHART		DESCRIPTION		ITEM
QUANTITY	PART NUMBER	MATERIALS LIST		
UNLESS OTHERWISE SPECIFIED		SIGNATURES		
1) All dimensions are in metric(mm).		DRAWN: SULLENZHANG	DATE: 14/SEP/20	
2) Tolerances are as follows:		CHECKED: ORIONLI	DATE: 15/SEP/20	
1 PL DEC ±0.20		ENGINEER:		
2 PL DEC ±0.10		APPROVAL: TOMMYXIE	DATE: 18/SEP/20	
3 PL DEC ±0.05		CUSTOMER:		
3) Note reference = Δ		THIS DRAWING IS SUPPLIED FOR INFORMATION ONLY. DESIGN FEATURES, SPECIFICATIONS AND PERFORMANCE DATA SHOWN HEREON ARE THE PROPERTY OF THE AMPHENOL CORPORATION. NO RIGHTS OF REPRODUCTION ARE IMPLIED. ALL DIMENSIONS ARE SUBJECT TO NORMAL MANUFACTURING VARIATIONS.		
PROCESS SPECIFICATIONS:		SINE SYSTEMS - www.amphenol-sine.com 44724 Morley Drive Clinton Township, MI 48036		
NEXT ASSY:		SIZE: B	TYPE: M-	DWG NO: AT60-16-08XX
		SCALE: NONE	REVISION: A2	

TITLE: CONTACT, PIN, STAMPED, SIZE 16, 20-22 AWG, AT & AHD-9 SERIES
 DWG NO: AT60-16-08XX
 REV: A2
 SH: 1
 OF: 1