

<b>PART NAME</b> FAN TRAY ASSEMBLY	<b>PART No.</b> FT-1170
------------------------------------	-------------------------

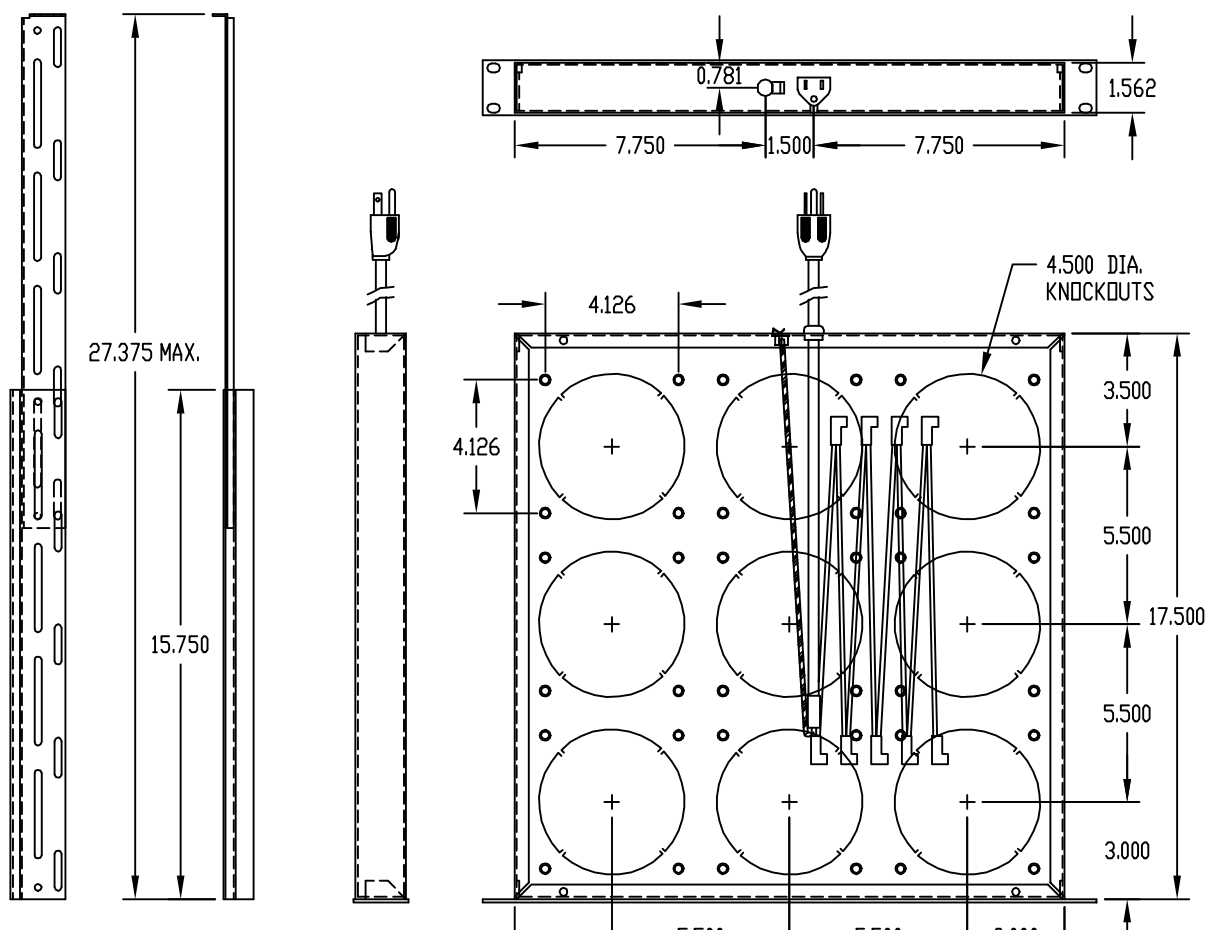

**MATERIAL:**  
 FAN TRAY CHASSIS & SUPPORT ANGLES — 16 GA. STEEL  
 PANEL — 12 GA. STEEL

**FINISH:**  
 WHITE TEXTURED OR METALLIC GRAY  
 0.278 x 0.406 OBLONG

<b>PART NAME</b> FAN	<b>PART No.</b> FN-1280
----------------------	-------------------------

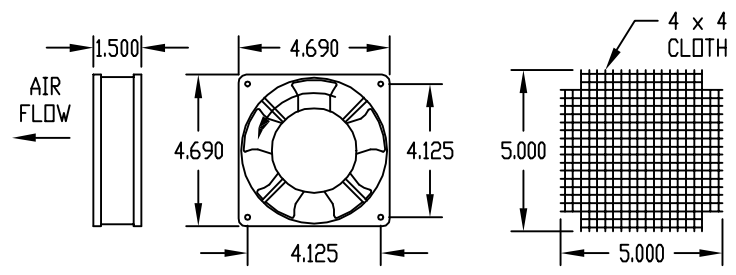

4 x 4 MESH 23 GA. HARDWARE CLOTH FINGER GUARD (SUPPLIED)

FAN HOUSING: ONE-PIECE ZINC DIE CASTING  
 FINISH: PLAIN OR BLACK  
 IMPELLER: THERMOPLASTIC (UL-94-V0)  
 MOUNTING HARDWARE SUPPLIED

POWER	CFM	WATTS	TEMP. RANGE
115 V.A.C.	105	19/17	-20°C. TO +60°C.

<b>PART NAME</b> WIRE FORM FINGER GUARD	<b>PART No.</b> FG-1281
---	-------------------------

**MATERIAL:**  
 RIBS — 0.091 DIA. STEEL WIRE  
 RINGS — 0.071 DIA. STEEL WIRE

**FINISH:** ZINC PLATED

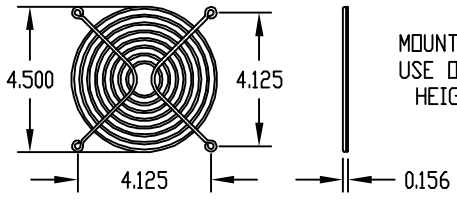

MOUNTING HARDWARE SUPPLIED.  
 USE OR THIS ITEM INCREASES OVERALL HEIGHT OF FAN TRAY TO 1.875