

# AT-41586

## Low Cost General Purpose Transistors



### Data Sheet

#### Description

Avago's AT-41586 is a general purpose NPN bipolar transistor that offers excellent high frequency performance. The AT-41586 is housed in a low cost surface mount .085" diameter plastic package. The 4 micron emitter-to-emitter pitch enables this transistor to be used in many different functions. The 14 emitter finger interdigitated geometry yields an intermediate sized transistor with impedances that are easy to match for low noise and moderate power applications. Applications include use in wireless systems as an LNA, gain stage, buffer, oscillator, and mixer. An optimum noise match near 50  $\Omega$  in the 1 to 2 GHz frequency range, makes this device easy to use as a low noise amplifier.

The AT-41586 bipolar transistor is fabricated using Avago's 10 GHz  $f_T$  Self-Aligned-Transistor (SAT) process. The die is nitride passivated for surface protection. Excellent device uniformity, performance and reliability are produced by the use of ion-implantation, self-alignment techniques, and gold metalization in the fabrication of this device.

#### 86 Plastic Package

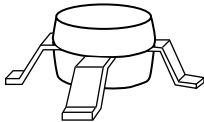

#### Pin Connections

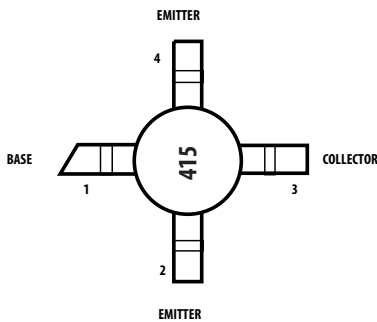

#### Features

- Low Noise Figure  
1.4 dB Typical at 1 GHz  
1.7 dB Typical at 2 GHz
- High Associated Gain  
17.0 dB Typical at 1 GHz  
12.5 dB Typical at 2 GHz
- Low Cost Surface Mount Package
- Tape and Reel Option Available
- Lead-free Option Available

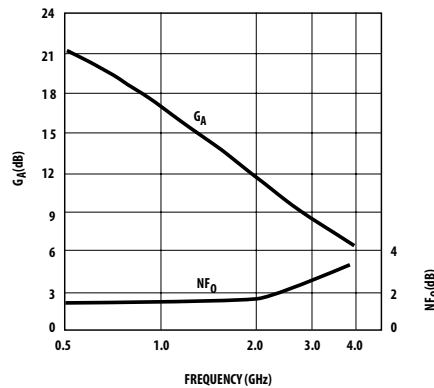

Figure 1. AT-41586 Noise Figure and Associated Gain vs. Frequency at  $V_{CE} = 8 V$ ,  $I_C = 10 mA$ .

## AT-41586 Absolute Maximum Ratings<sup>[1]</sup>

Symbol	Parameter	Units	Absolute Maximum <sup>[1]</sup>
$V_{EBO}$	Emitter-Base Voltage	V	1.5
$V_{CBO}$	Collector-Base Voltage	V	20
$V_{CEO}$	Collector-Emitter Voltage	V	12
$I_C$	Collector Current	mA	60
$P_T$	Power Dissipation <sup>[2]</sup>	mW	500
$T_j$	Junction Temperature	°C	150
$T_{STG}$	Storage Temperature	°C	-65 to 150

Thermal Resistance:<sup>[3]</sup>

$$\theta_{jc} = 165^\circ\text{C/W}$$

### Notes:

1. Operation of this device above any one of these parameters may cause permanent damage.
2.  $T_{CASE} = 25^\circ\text{C}$ .
3. See MEASUREMENTS section, "Thermal Resistance," for more information.

## Electrical Specifications, $T_A = 25^\circ\text{C}$ , $V_{CE} = 8\text{ V}$

Symbol	Parameters and Test Conditions	Unit	Min.	Typ.	Max.	
$NF_0$	Optimum Noise Figure: $I_C = 10\text{ mA}$	f = 1.0 GHz f = 2.0 GHz f = 4.0 GHz	dB	1.4 1.7 3.0		
$G_A$	Gain @ $NF_0$ : $I_C = 10\text{ mA}$	f = 1.0 GHz f = 2.0 GHz f = 4.0 GHz	dB	17.0 12.5 8.0		
$ S_{21E} ^2$	Insertion Power Gain: $I_C = 25\text{ mA}$	f = 1.0 GHz f = 2.0 GHz	dB	17.0 11.0		
$P_{1dB}$	Power Output @ 1 dB Gain Compression: $I_C = 25\text{ mA}$	f = 2.0 GHz	dBm	18.0		
$G_{1dB}$	1 dB Compressed Gain: $I_C = 25\text{ mA}$	f = 2.0 GHz	dB	13.0		
$f_T$	Gain Bandwidth Product: $I_C = 25\text{ mA}$		GHz	8.0		
$h_{FE}$	Forward Current Transfer Ratio: $I_C = 10\text{ mA}$			30	150	270
$I_{CBO}$	Collector Cutoff Current: $V_{CB} = 8\text{ V}$		$\mu\text{A}$		0.2	
$I_{EBO}$	Emitter Cutoff Current: $V_{EB} = 1\text{ V}$		$\mu\text{A}$		1.0	

### Note:

1. For more information on outlines 86, refer to "Tape and Reel Packaging for Surface Mount Devices."

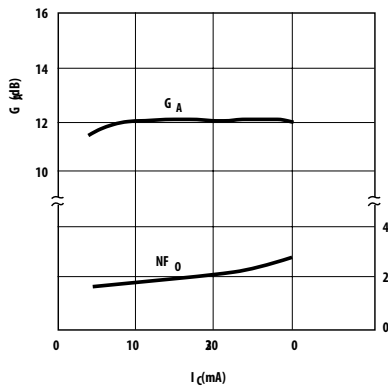

Figure 2. AT-41586 Optimum Noise Figure and Associated Gain vs. Collector Current at  $V_{CE} = 8\text{ V}$ ,  $f = 2.0\text{ GHz}$ .

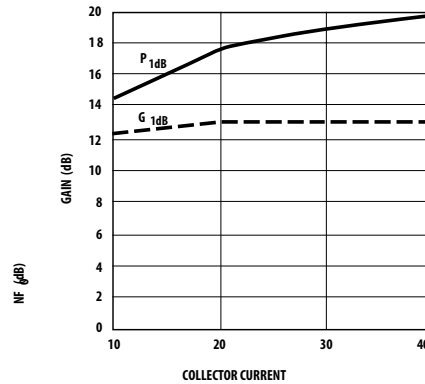

Figure 3. AT-41586  $P_{1dB}$  and  $G_{1dB}$  vs. Collector Current at  $V_{CE} = 8\text{ V}$ ,  $f = 2.0\text{ GHz}$ .

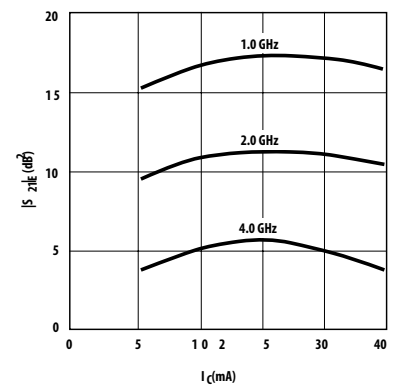

Figure 4. AT-41586 Insertion Power Gain vs. Collector Current and Frequency at  $25^\circ\text{C}$ ,  $V_{CE} = 8\text{ V}$ .

### AT-41586 Typical Scattering Parameters at $T_A = 25^\circ\text{C}$

$V_{CE} = 8\text{ V}$ ,  $I_C = 10\text{ mA}$ ,  $Z_o = 50\ \Omega$

Frequency (GHz)	$S_{11}$			$S_{21}$			$S_{12}$		$S_{22}$	
	Mag.	Ang.	(dB)	Mag.	Ang.	(dB)	Mag.	Ang.	Mag.	Ang.
0.100	0.78	-39	28.4	26.3	154	-36.4	0.015	71	0.91	-16
0.200	0.71	-71	26.9	22.1	134	-31.7	0.026	59	0.79	-27
0.300	0.65	-95	25.2	18.1	122	-29.8	0.032	50	0.67	-34
0.400	0.61	-113	23.5	15.0	119	-28.8	0.036	44	0.58	-38
0.500	0.59	-127	22.0	12.6	114	-28.1	0.039	43	0.52	-40
0.600	0.57	-137	20.7	10.8	100	-27.5	0.042	43	0.47	-40
0.700	0.56	-146	19.6	9.5	95	-27.1	0.044	43	0.44	-41
0.800	0.56	-154	18.5	8.4	91	-26.5	0.047	43	0.42	-41
0.900	0.55	-160	17.6	7.6	86	-26.1	0.049	44	0.40	-42
1.000	0.55	-166	16.8	6.9	83	-25.8	0.051	47	0.38	-42
1.500	0.55	173	13.4	4.7	70	-23.8	0.064	49	0.34	-45
2.000	0.57	157	10.9	3.5	57	-22.0	0.079	49	0.32	-52
2.500	0.59	144	9.2	2.9	44	-20.6	0.093	48	0.31	-61
3.000	0.62	133	7.6	2.4	34	-19.3	0.108	47	0.30	-71
3.500	0.64	123	6.0	2.0	25	-18.1	0.124	45	0.30	-83
4.000	0.67	114	5.1	1.8	16	-17.0	0.141	42	0.31	-95
4.500	0.70	106	4.1	1.6	5	-15.9	0.159	39	0.32	-108
5.000	0.73	99	2.9	1.4	-3	-15.0	0.176	35	0.32	-121
5.500	0.76	93	1.6	1.2	-8	-14.2	0.193	31	0.34	-135
6.000	0.78	88	0.8	1.1	-18	-13.5	0.209	31	0.36	-150

### AT-41586 Typical Noise Parameters at $T_c = 25^\circ\text{C}$ ,

$Z_o = 50\ \Omega$ ,  $I_C = 10\text{ mA}$ ,  $V_{CE} = 8\text{ V}$

Frequency (GHz)	$NF_0$ (dB)	$\Gamma_{opt}$ Mag.	Ang.	$R_N/50\ \Omega$
0.1	1.3	0.12	3	0.17
0.5	1.3	0.10	16	0.17
1.0	1.4	0.04	43	0.16
2.0	1.7	0.12	-145	0.16

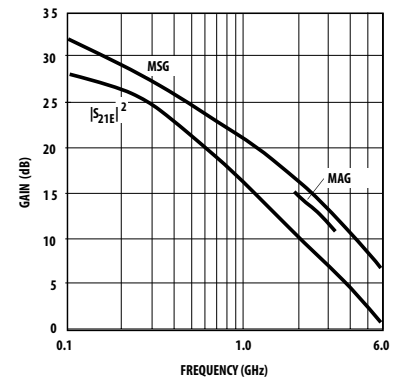

Figure 5. AT-41586 Insertion Power Gain, Maximum Available Gain and Maximum Stable Gain vs. Frequency at  $V_{CE} = 8\text{ V}$ ,  $I_C = 10\text{ mA}$ .

## AT-41586 Typical Scattering Parameters at $T_A = 25^\circ\text{C}$

$V_{CE} = 8\text{ V}$ ,  $I_C = 25\text{ mA}$ ,  $Z_o = 50\ \Omega$

Frequency (GHz)	$S_{11}$			$S_{21}$			$S_{12}$		$S_{22}$	
	Mag.	Ang.	(dB)	Mag.	Ang.	(dB)	Mag.	Ang.	Mag.	Ang.
0.100	0.64	-61	31.9	39.4	154	-37.0	0.014	64	0.82	-24
0.200	0.59	-101	29.2	28.7	169	-33.1	0.022	53	0.64	-35
0.300	0.56	-125	26.6	21.4	124	-31.7	0.026	49	0.53	-38
0.400	0.55	-140	24.6	17.0	111	-30.4	0.030	49	0.47	-39
0.500	0.54	-151	22.9	14.0	104	-29.6	0.033	50	0.43	-38
0.600	0.54	-159	21.4	11.7	97	-28.8	0.036	52	0.40	-38
0.700	0.54	-166	20.1	10.1	91	-28.1	0.039	53	0.40	-37
0.800	0.54	-171	19.0	8.9	86	-27.5	0.042	55	0.38	-37
0.900	0.54	-176	18.0	7.9	81	-26.9	0.045	56	0.37	-37
1.000	0.55	177	17.1	7.2	77	-26.3	0.048	57	0.36	-37
1.500	0.57	164	13.6	4.8	64	-23.8	0.064	59	0.34	-42
2.000	0.57	152	11.1	3.6	55	-21.9	0.080	57	0.32	-49
2.500	0.60	141	9.2	2.9	44	-20.0	0.100	55	0.31	-58
3.000	0.62	132	7.6	2.4	34	-18.4	0.120	52	0.31	-68
3.500	0.64	124	6.4	2.1	24	-17.0	0.140	49	0.31	-80
4.000	0.67	116	5.6	1.9	18	-14.8	0.180	45	0.32	-94
4.500	0.70	109	4.1	1.6	9	-15.9	0.160	45	0.30	-109
5.000	0.73	102	3.5	1.5	1	-15.3	0.170	42	0.30	-123
5.500	0.77	96	2.3	1.3	-7	-14.4	0.190	38	0.32	-138
6.000	0.76	90	1.6	1.2	-14	-13.9	0.200	33	0.35	-152

## Outline 86 Dimensions

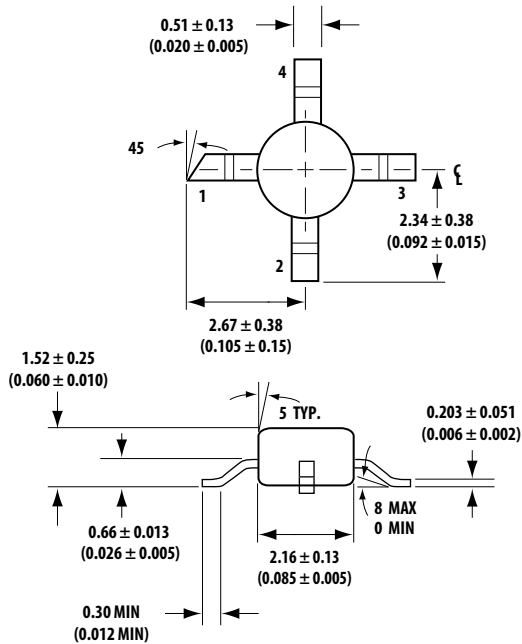

DIMENSIONS ARE IN MILLIMETERS (INCHES)

## Ordering Information

Part Numbers	No. of Devices	Comments
AT-41586-BLKG	100	Bulk
AT-41586-TR1G	1000	7" Reel
AT-41586-TR2G	4000	13" Reel

## Device Orientation

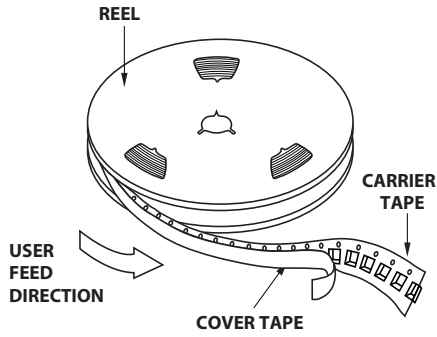

## Tape Dimensions and Product Orientation

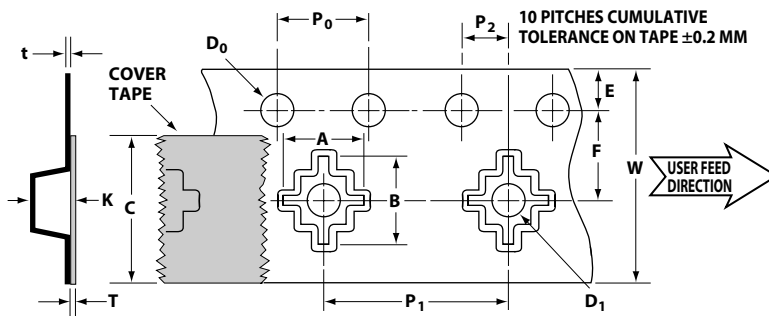

DESCRIPTION		SYMBOL	SIZE (mm)	SIZE (INCHES)
CAVITY	LENGTH	$A_0$	$6.45 \pm 0.10$	$0.254 \pm 0.004$
	WIDTH	$B_0$	$5.13 \pm 0.10$	$0.202 \pm 0.004$
	DEPTH	$K_0$	$2.11 \pm 0.10$	$0.083 \pm 0.004$
	PITCH	$P_1$	$8.00 \pm 0.10$	$0.315 \pm 0.004$
	BOTTOM HOLE DIAMETER	$D_1$	1.50 min.	0.059 min.
PERFORATION	DIAMETER	$D_0$	$1.50 + 0.10/-0$	$0.059 + 0.004/-0$
	PITCH	$P_0$	$4.00 \pm 0.10$	$0.157 \pm 0.004$
	POSITION	$E$	$1.75 \pm 0.10$	$0.069 \pm 0.004$
CARRIER TAPE	WIDTH	$W$	$8.00 \pm 0.30$	$0.315 \pm 0.012$
	THICKNESS	$t$	$0.255 \pm 0.013$	$0.0100 \pm 0.0005$
COVER TAPE	WIDTH	$C$	$9.19 \pm 0.10$	$0.362 \pm 0.004$
	TAPE THICKNESS	$T_t$	$0.051 \pm 0.010$	$0.0020 \pm 0.0004$
DISTANCE BETWEEN CENTERLINE	CAVITY TO PERFORATION (WIDTH DIRECTION)	$F$	$5.51 \pm 0.05$	$0.217 \pm 0.002$
	CAVITY TO PERFORATION (LENGTH DIRECTION)	$P_2$	$2.00 \pm 0.05$	$0.079 \pm 0.002$

For product information and a complete list of distributors, please go to our web site: [www.avagotech.com](http://www.avagotech.com)

Avago, Avago Technologies, and the A logo are trademarks of Avago Technologies in the United States and other countries. Data subject to change. Copyright © 2005-2008 Avago Technologies. All rights reserved. Obsoletes 5989-2651EN AV02-1459EN - August 8, 2008

**AVAGO**  
TECHNOLOGIES