

**STRAIGHT SQUARE FLANGE JACK SOLDER TYPE  
CABLE .085**

**R124.256.003  
SERIES SMA-COM**

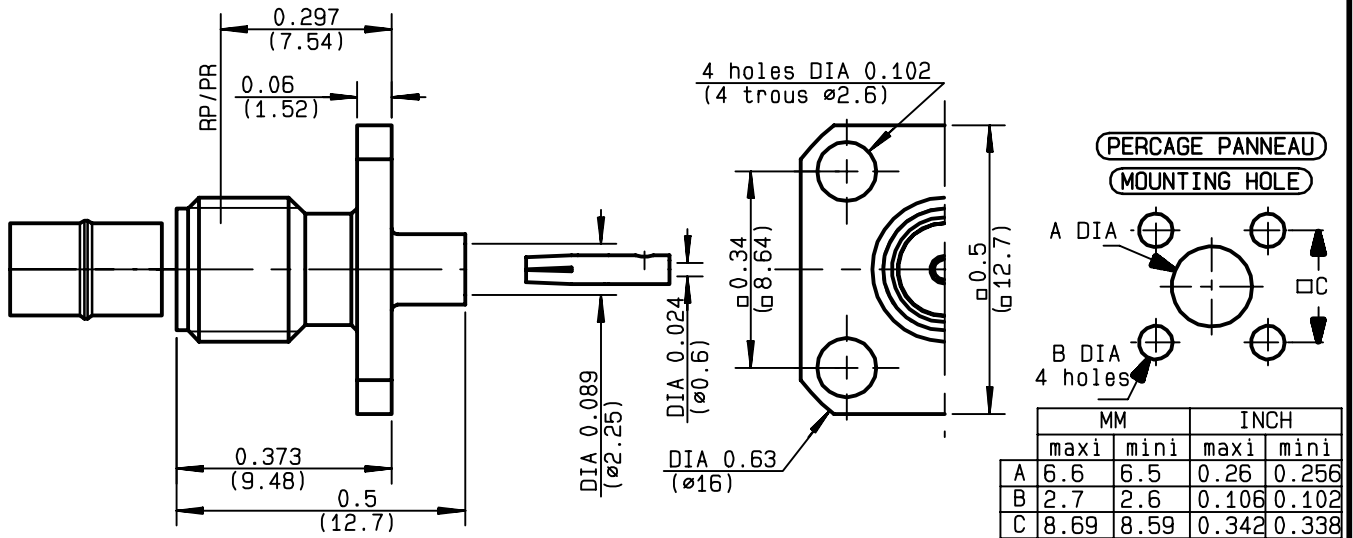

NOMINAL IMPEDANCE	<b>50</b> Ω
FREQUENCY RANGE	<b>0-18</b> GHz
TEMPERATURE RATING	<b>-65/+105</b> °C
V.S.W.R	<b>1.07</b> + <b>.01</b> x F(GHz)Maxi
RF INSERTION LOSS	<b>0.05</b> √F(GHz) dB Maxi
VOLTAGE RATING	<b>335</b> Veff Maxi
DIELECTRIC WITHSTANDING VOLTAGE	<b>750</b> Veff Mini
INSULATION RESISTANCE	<b>5000</b> MΩMini
HERMETIC SEAL	<b>NA</b> Atm.cm <sup>3</sup> /s
LEAKAGE (pressurized only)	<b>NA</b>
MECHANICAL DURABILITY	<b>100</b> Cycles
WEIGHT	<b>2.65</b> gr
SPECIFICATION	

CABLES : <b>KS 1</b>	
<b>RG 405</b>	
OTHERS CHARACTERISTICS	
CABLE RETENTION	<b>130</b> N Mini
CENTER CONTACT RETENTION	
Axial force - mating end	<b>NA</b> N Mini
Axial force - opposite end	<b>NA</b> N Mini
Torque	<b>NA</b> cm.N Mini
RECOMMENDED TORQUES	
Mating	<b>NA</b> cm.N
Panel nut	<b>NA</b> cm.N
Clamp nut	<b>NA</b> cm.N

CONNECTOR PARTS	MATERIALS	FINISH	(all values are given in micrometers)
BODY	BRASS	GOLD 0.2 OVER NICKEL 2	
OUTER CONTACT			
CENTER CONTACT	BERYLLIUM COPPER	GOLD 1.3 OVER COPPER 2.5	
INSULATOR	PTFE	-	
GASKET		-	
OTHERS PIECES			

ISSUE	CREATION DATE	FILE PART-NUMBER
<b>9847B00</b>	<b>15/05/1997</b>	<b>96-1200-073</b>



**RADIALL®**

TRIQUES

The information given here is subject to change without notice.  
Design changes may be in order to improve the product .

*Connect to the future*



**R124.256.003**

ISSUE **9847B00** SERIES **SMA-COM**

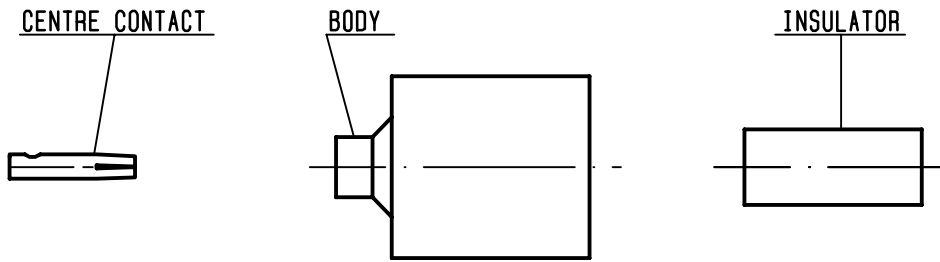

①

Take the tool kit : R282.120.000  
Strip the dielectric of the cable .  
Stripping tool cable : R282.051.000  
Trimmer : R282.063.000  
Clean the cable .  
-

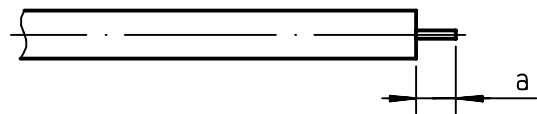

Stripping	a	b	c	d	e
inch	0.125 0	0	0	0	0
mm	3.17				

②

Screw the positioner R282.744.220 onto the soldering jig R282.740.000  
Slide contact into positioner .  
Insert solder gauge R282.862.060 between contact and cable .  
Tighten and solder the contact .

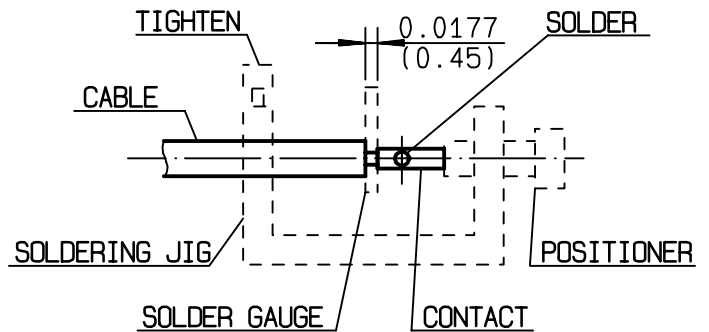

③

After cooling remove cable assembly from the jig .  
Screw positioner R282.744.010 into the connector .  
Slide cable into the connector until it bottoms againsts positioner R282.744.010 .  
Tighten .  
Put 3 rings of solder around the cable and solder .

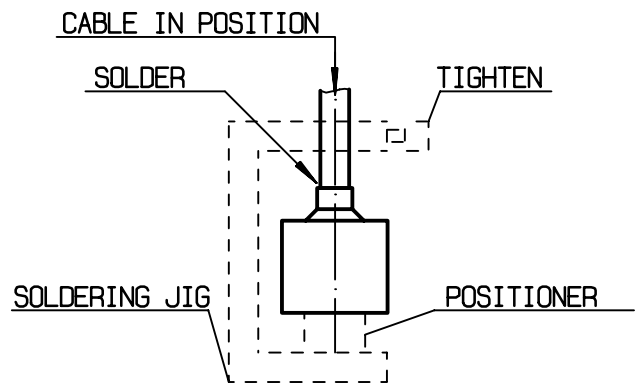

④

After cooling remove cable assembly from the jig .  
Screw positioner cut R282.914.010  
Cut the dielectric flush to clamp braid sleeve with tool R282.915.010.  
Screw female dielectric insert tool onto connector and insert insulator with the dielectric plunger R282.730.043

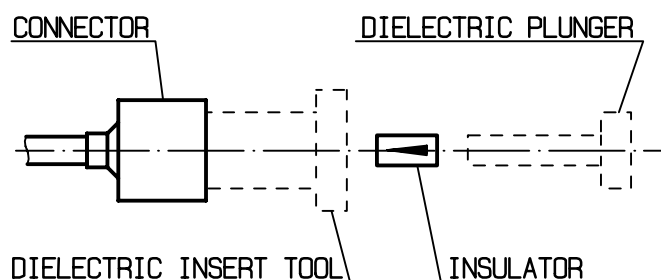

TRIQUES