

TOP VIEW

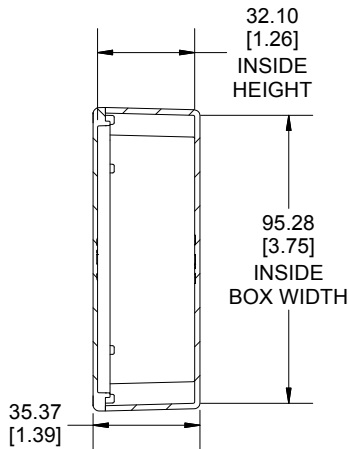

**SECTION A-A
END VIEW**

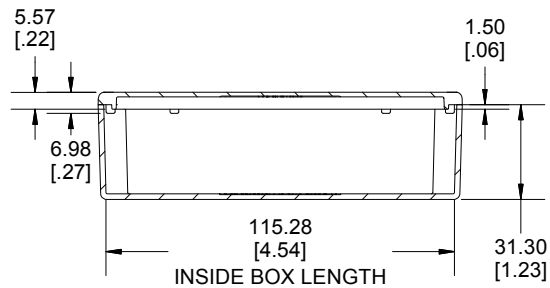
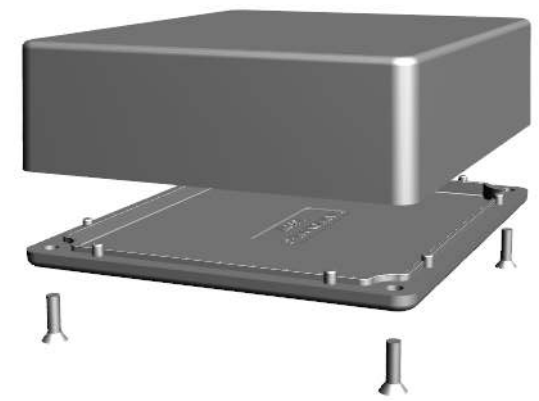

**SECTION B-B
SIDE VIEW**

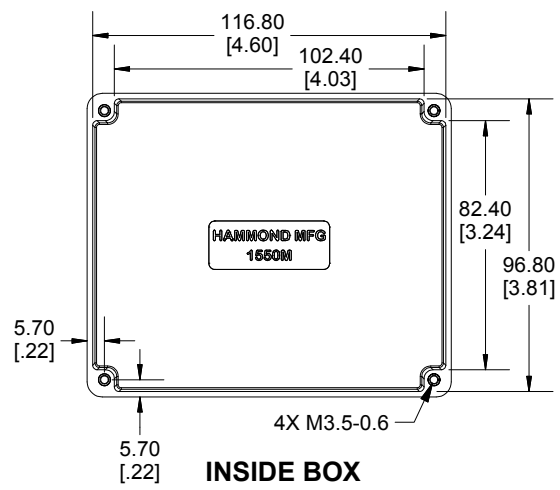
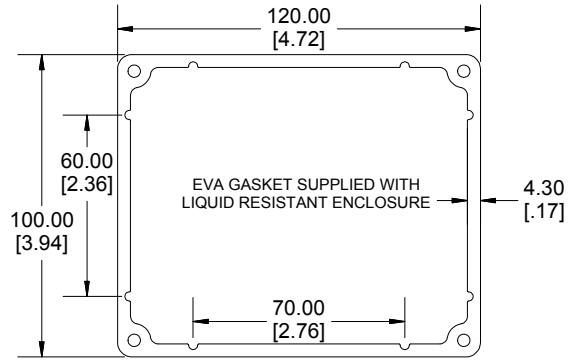

INSIDE BOX

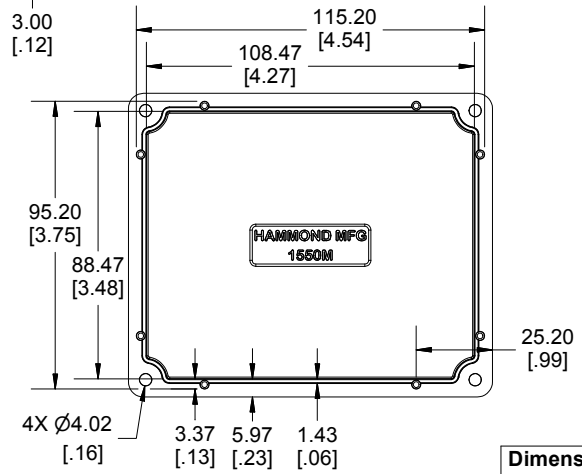

INSIDE LID

Enclosures can be Factory Modified (Milling, Drilling, Printing etc.)
Contact Factory mjm@hammondmfg.com for quotes
Solid models of this enclosure available in STEP or IGES.

NOTE
Purchased assembly includes box, lid and 4 cover screws.
Box and lid are made from Diecast Aluminum Alloy.
EVA Gasket supplied with liquid resistant enclosure.

PART NUMBERS	
1550M Enclosure	
Natural Finish Enclosure	1550M
Black Textured Enclosure	1550MBK
1550M Liquid Resistant Enclosure (EVA Gasket)	
Natural Finish Enclosure	1550WM
Black Textured Enclosure	1550WMBK
ACCESSORIES	
Recommended Torque: 75 ozf.in / 55 cN.m	
Standard Cover Screws	
Plated Cover Screws (Pkg 100) [M3.5-0.6 x 12mm]	1550MS100
Black Cover Screws (Pkg 100) [M3.5-0.6 x 12mm]	1550MS100BK
Liquid Resistant Cover Screws and Gaskets	
Stainless Steel Cover Screws (Pkg 100) [M3.5 x 12mm, With O-Ring]	1550WMS100
Black Stainless Steel Cover Screws (Pkg 100) [M3.5 x 12mm, With O-Ring]	1550WMS100BK
EVA Pre-formed Gasket Black	1550MEGASKET
Silicone Pre-formed Gasket Black	1550MSGASKET

Dimensions:
mm
[inches]

**HAMMOND
MANUFACTURING®**
1550M
www.hammondmfg.com