

REVISIONS			
REV.	DESCRIPTION	DATE	APPROVED
A	INITIAL RELEASE	03/27/12	D.N.

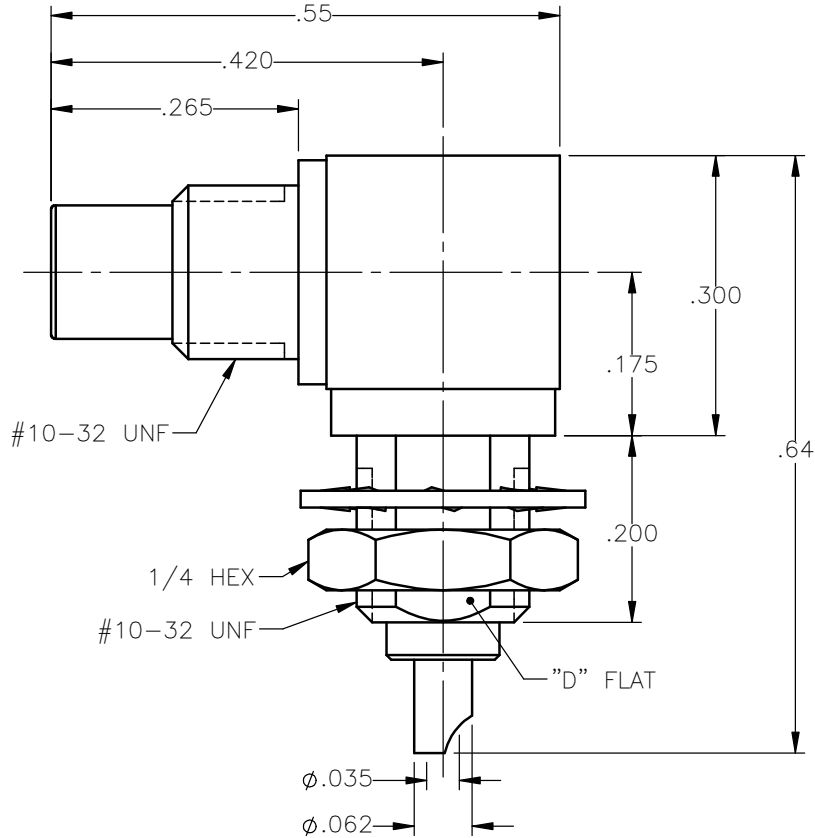

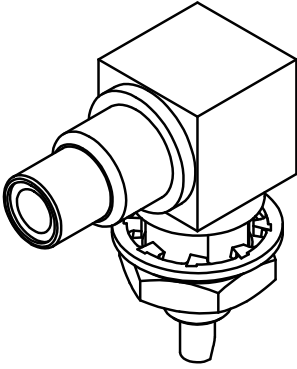

NOTES:

MATERIALS:

1. INSULATORS = VIRGIN WHITE TEFLON PER ASTM D1710, GRADE 1, TYPE I, CLASS "B".
2. LOCKWASHER = PHOSPHOR BRONZE PER ASTM B139, COPPER ALLOY C53400, TEMPER H04.
3. ALL OTHER METAL PARTS = BRASS PER ASTM B16, ALLOY C36000, TEMPER H02.

FINISHES:

1. CONTACTS = GOLD PLATE PER MIL-G-45204, TYPE II, CLASS 1, GRADE C, OVER .00010 TO .00020 STRESS FREE SULFAMATE NICKEL PER QQ-N-290.
2. ALL OTHER METAL PARTS = NICKEL PLATE PER QQ-N-290, CLASS 1, GRADE G, EXCEPT .0001 TO .0002 THICK OVER .00005 TO .0001 THICK COPPER PER MIL-C-14550.

UNLESS OTHERWISE SPECIFIED DIMENSIONS ARE IN INCHES TOLERANCES ON		DWN: D.N.	DATE: 03/27/12	 <b>Property of Radiall</b> This document cannot be reproduced or communicated to a third party without prior written permission of RADIALL.	
		CHKD: J.S.	DATE: 03/27/12		
DECIMAL	ANGLE	APVD: J.M.	DATE: 03/27/12	<b>SMC RIGHT ANGLE MALE JACK BULKHEAD FRONT MOUNT SOLDER POT RECEPTACLE</b>	
REFERENCE:	MATERIALS & FINISHES:	SEE NOTES			
ORIGINATED: D.N. DATE: 03/27/12				REV: A	SHEET 1 OF 1

1012-7511-000