

THIS DRAWING IS UNPUBLISHED. RELEASED FOR PUBLICATION
 © COPYRIGHT - By - ALL RIGHTS RESERVED.

LOC		DIST		REVISIONS			
P	LTR	DESCRIPTION		DATE	DWN	APVD	
AF	50	D4	REVISED PER ECR-18-014989		26SEP2018	BW	JH

IDENTIFICATION NUMBER 43 FOR MAGNET WIRE RANGE

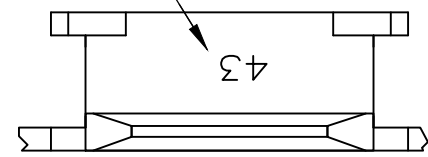

- 1 CONTINUOUS STRIP ON REELS WITH TERMINALS LOCATED ON 8.38±0.08 [.330±.003] CENTERS.
- 2 SLOT ACCEPTS SINGLE OR DOUBLE MAGNET WIRE FOR THE BELOW WIRE RANGES.
 COPPER: 1.61mm [#14] AWG, ALUMINIUM: 1.83 mm [#13] AWG OR
 SLOT ACCEPTS SINGLE MAGNET WIRE FOR THE BELOW WIRE RANGES.
 COPPER: 1.83mm [#13] AWG, ALUMINIUM: 2.05 mm [#12] AWG
 ALUMINIUM WIRE RANGE IS APPLICABLE FOR POST TIN PLATED PARTS ONLY.
 SLOT ACCEPTS THE SAME TYPE AND SIZE OF WIRE IN THE SLOT.
 TWO 1.61mm [#14] AWG COPPER MAGNET WIRES ACCEPTABLE AT CAVITY ANVIL HEIGHT OF 3.94-4.19 [.155-.165].
- 3 AFTER INSERTION INTO PLASTIC HOLDER TAB PORTION MUST BE BENT OVER 45° TO 90° OR POTTED-IN TO PREVENT PULL-OUT WHEN MATING RECEPTACLE IS DISCONNECTED.
- 4 VARNISH RESIST OVER TIN.

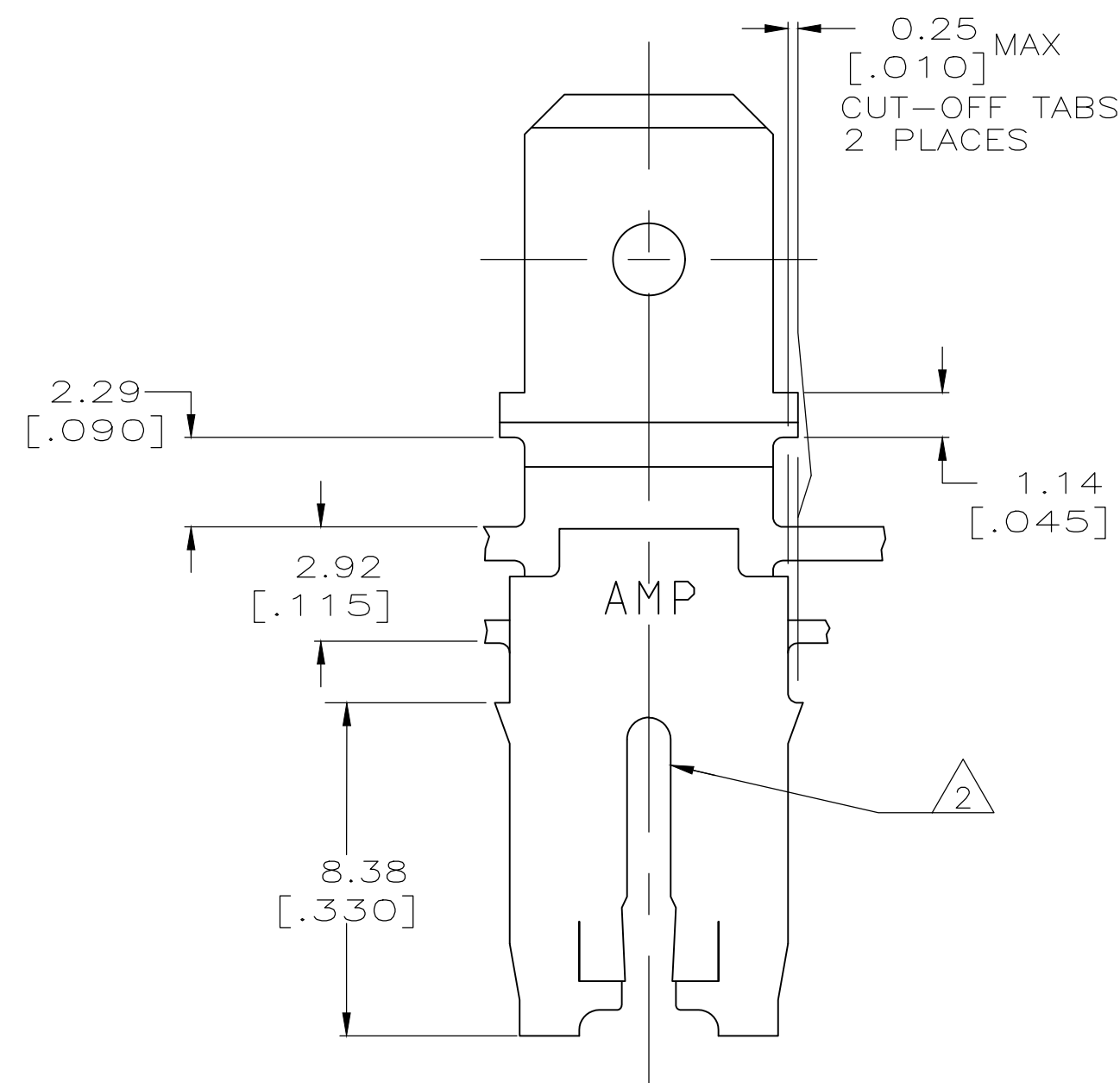
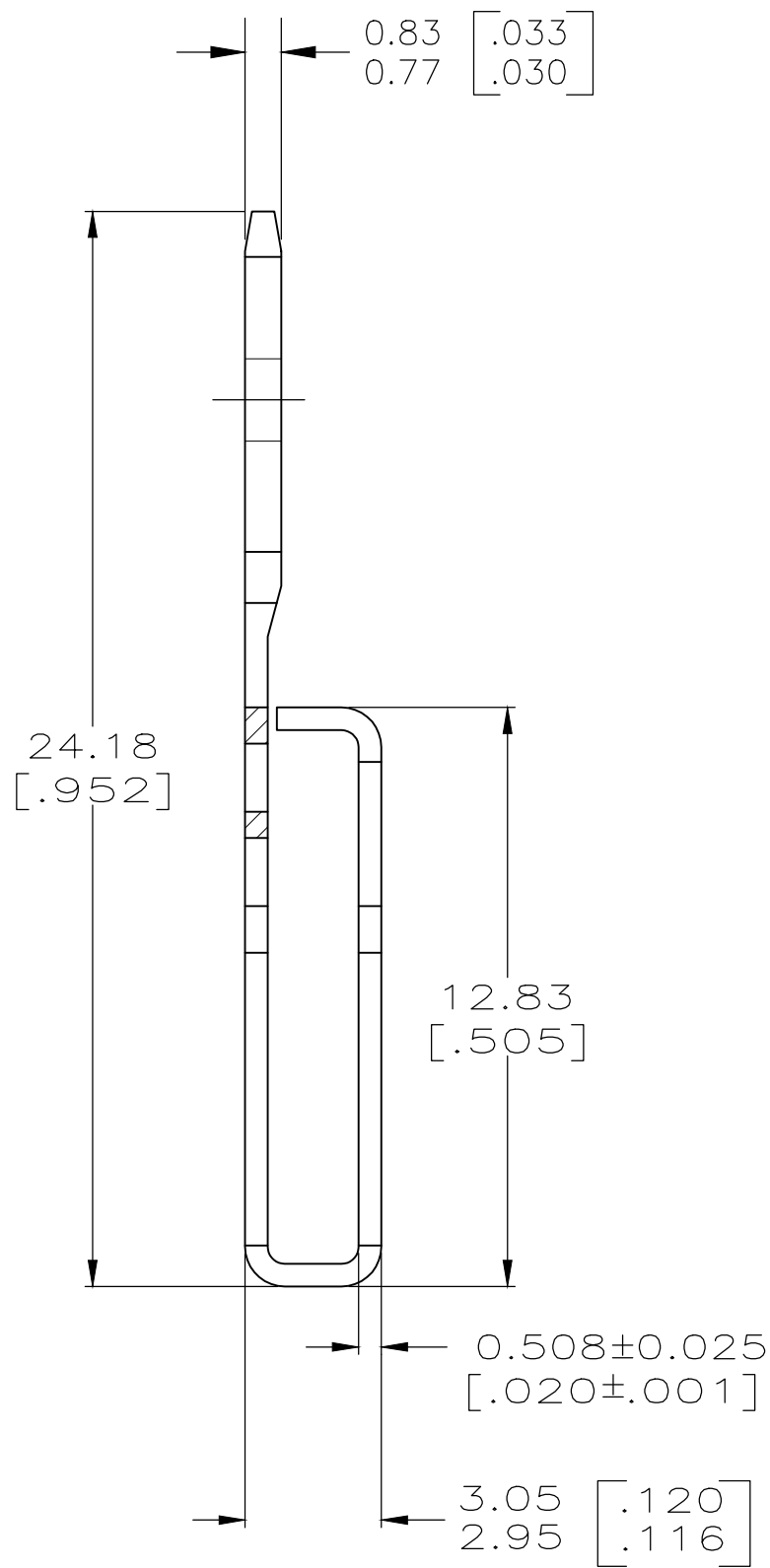
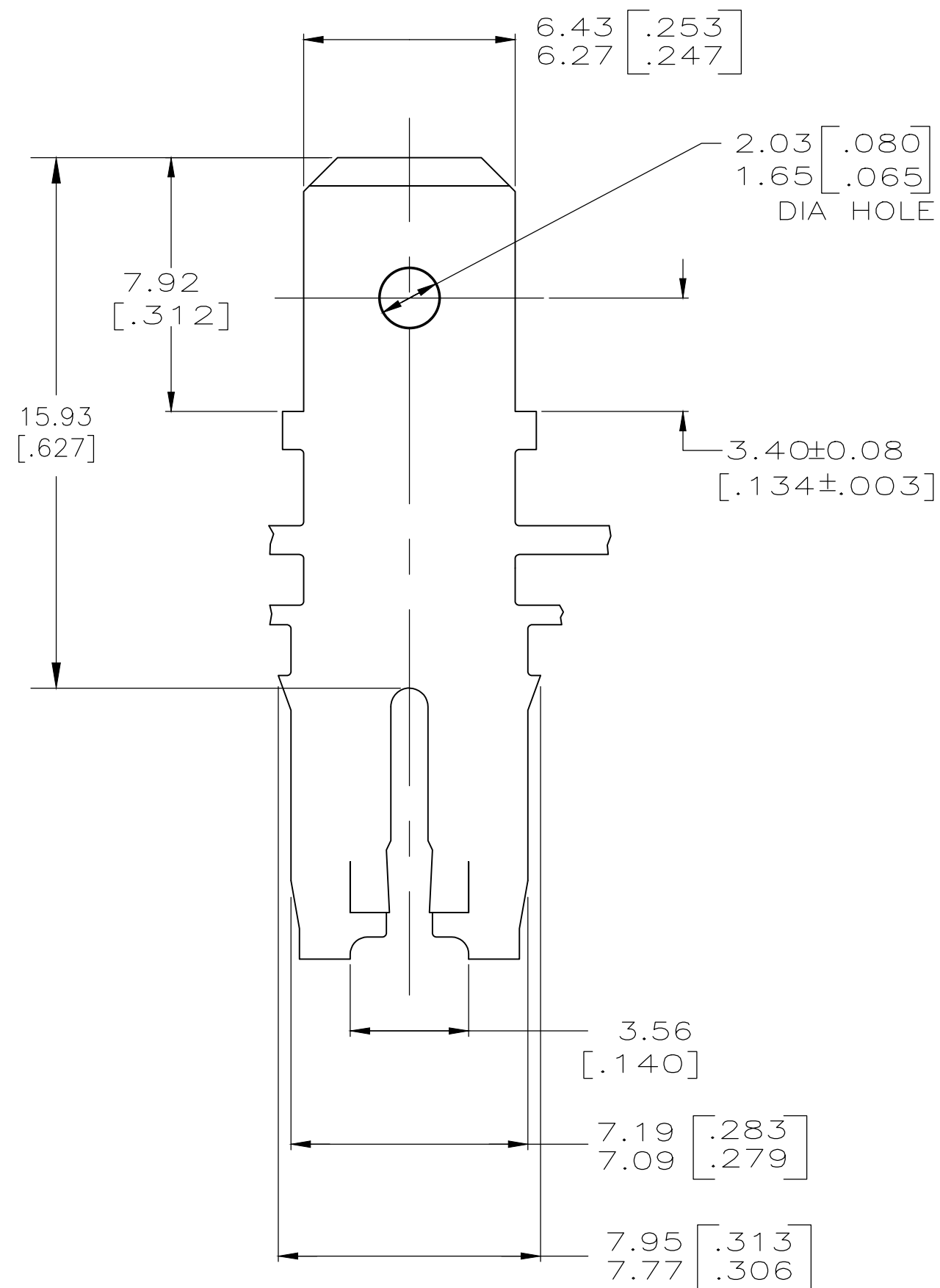

4	63816-2
TIN PLATED	63816-1
FINISH	PART NO

THIS DRAWING IS A CONTROLLED DOCUMENT.		DWN 29/OCT/94 MICHAEL S. FEHER	STE TE Connectivity	
DIMENSIONS: INCHES		CHK 31/OCT/94 JEFF R. RUTH		
TOLERANCES UNLESS OTHERWISE SPECIFIED:		APVD 31/OCT/94 NELSON E. NEFF	NAME TAB, 6.35 [.250] FASTON,™ MAG-MATE™	
0 PLC ± -	1 PLC ± -	PRODUCT SPEC 108-2053	SIZE A2	CAGE CODE 00779
2 PLC ± 0.25 [.010]	3 PLC ± -	APPLICATION SPEC 114-2066	DRAWING NO C-63816	RESTRICTED TO -
4 PLC ± -	ANGLES ± -	MATERIAL BRASS	WEIGHT -	SCALE 6:1
FINISH SEE TABLE		CUSTOMER DRAWING		SHEET 1 OF 1 REV D4