

Pb THIS PRODUCT MANUFACTURED WITH LEAD-FREE PROCESSING

LEAD STYLE
-01: 10 LS, 8 PAIR HS

CABLE LENGTH (INCHES)
04.0 TO XX.X
(SEE NOTE 7)

END OPTION
-1: DCH-PF 1 x8 PAIR
-2: DCH-PF 2 x4 PAIR
-3: ECUE (SEE FIG 5, SHT 4)
(SEE NOTE 3)
-4: ARC6-08-LU
(SEE FIG 16, SHT 5)

FQSFP CONTACT TYPE
-PF: PRESS FIT

PLATING SPECIFICATION
-L: 10µ" Au OVER 50µ"
Ni IN CONTACT
AREA, TIN ON TAIL
-S: 30µ" Au OVER 50µ"
Ni IN CONTACT
AREA, TIN ON TAIL

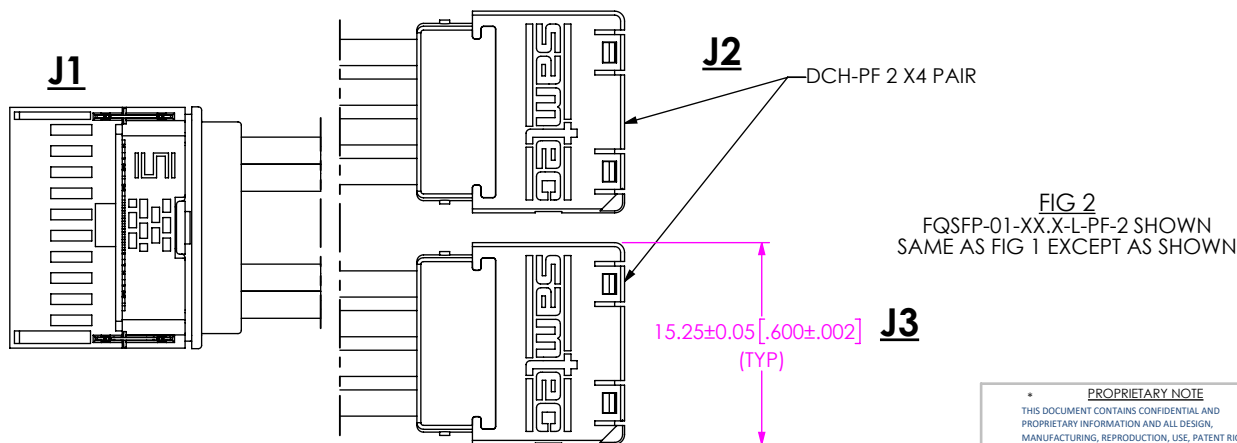
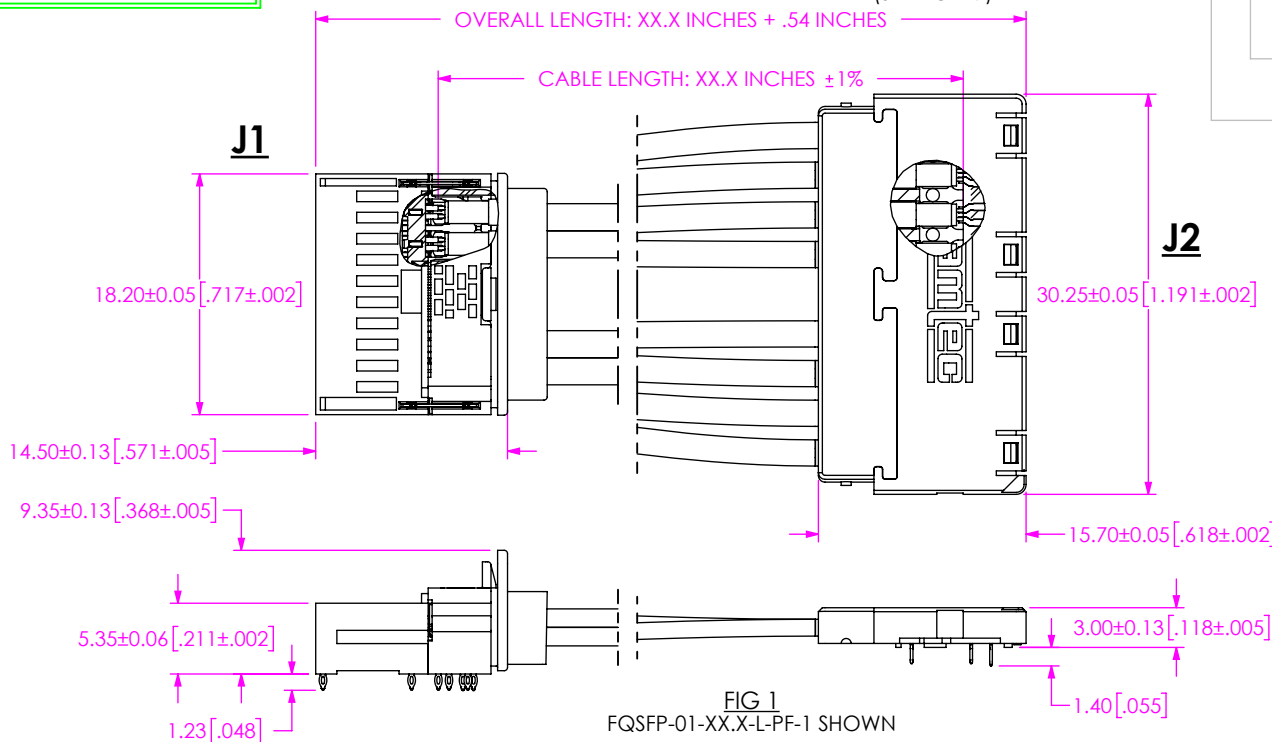

NOTES:

1. ALL HIGH SPEED CONTACTS TO BE 100% HI-POT TESTED AT 300V.
2. ALL HIGH SPEED CONTACTS TO BE 100% ELECTRICALLY TESTED FOR SHORTS AND OPENS.
3. FOR -3 END OPTIONS OVER 16Gbs MATE TO UEC5-XXX-2-XXX-D-RA-X-XX.
FOR -3 END OPTION UNDER 16Gbs MATE TO UEC5-XXX-1-X-D-RA-X-A-XX.
4. LABEL TO BE CENTERED ON CABLE FOR ALL END OPTIONS SHOWING PART NUMBER, ORDER NUMBER, DATE CODE.
5. FQSFP END TO BE PACKAGED WITH CAP-FQSFP AND DCH END TO BE PACKAGED WITH DCH-CAP-XX.
6. FQSFP MUST BE USED WITH QSFP-C-X-X-X-XX-X AND HS-QSFP-XX-XX-XX.
7. CABLE LENGTHS OVER 19.68" NOT SUPPORTED BY SI.

<p>PROPRIETARY NOTE</p> <p>THIS DOCUMENT CONTAINS CONFIDENTIAL AND PROPRIETARY INFORMATION AND ALL DESIGN, MANUFACTURING, REPRODUCTION, USE, PATENT RIGHTS AND SALES RIGHTS ARE EXPRESSLY RESERVED BY SAMTEC, INC. THIS DOCUMENT SHALL NOT BE DISCLOSED, IN WHOLE OR PART, TO ANY UNAUTHORIZED PERSON OR ENTITY NOR REPRODUCED, TRANSFERRED OR INCORPORATED IN ANY OTHER PROJECT IN ANY MANNER WITHOUT THE EXPRESS WRITTEN CONSENT OF SAMTEC, INC.</p>	<p>DO NOT SCALE DRAWING SHEET SCALE: 1.75:1</p>
	<p>DESCRIPTION: QSFP FLYOVER CABLE ASSEMBLY</p> <p>DWG. NO. FQSFP-XX-XX.X-X-XX-X</p>



520 PARK EAST BLVD, NEW ALBANY, IN 47150
PHONE: 812-944-6733 FAX: 812-948-5047
e-Mail info@SAMTEC.com code 55322

TABLE 1 SIGNAL MAPPING		
J1	NAME	J2
1	GND1	GND1
2	TX2n	14
3	TX2p	13
4	GND1	GND1
5	TX4n	10
6	TX4p	9
7	GND1	GND1
13	GND2	GND2
14	RX3p	6
15	RX3n	5
16	GND2	GND2
17	RX1p	2
18	RX1n	1
19	GND2	GND2
20	GND2	GND2
21	RX2n	3
22	RX2p	4
23	GND2	GND2
24	RX4n	7
25	RX4p	8
26	GND2	GND2
32	GND1	GND1
33	TX3p	11
34	TX3n	12
35	GND1	GND1
36	TX1p	15
37	TX1n	16
38	GND1	GND1

WITHIN THIS CABLE ASSEMBLY,
POSITIONS LABELED WITH A SPECIFIC
GND# ARE COMMON AND TIED TO
TW IN AX SHIELD

ON THE MATING BOARD ASSEMBLY,
SAMTEC RECOMMENDS
IMPLEMENTING A COMMON GND
REFERENCE TYING ALL GND#'S
TOGETHER

J1	NAME	J2
8	ModseL	NC
9	ResetL	NC
10	VccRx	NC
11	SCL	NC
12	SDA	NC
27	ModPrsL	NC
28	IntL	NC
29	VxxTx	NC
30	Vcc1	NC
31	LPMode	NC

ALL NC ARE ROUTED VIA
COMPLIANT TAILS TO THE PCB

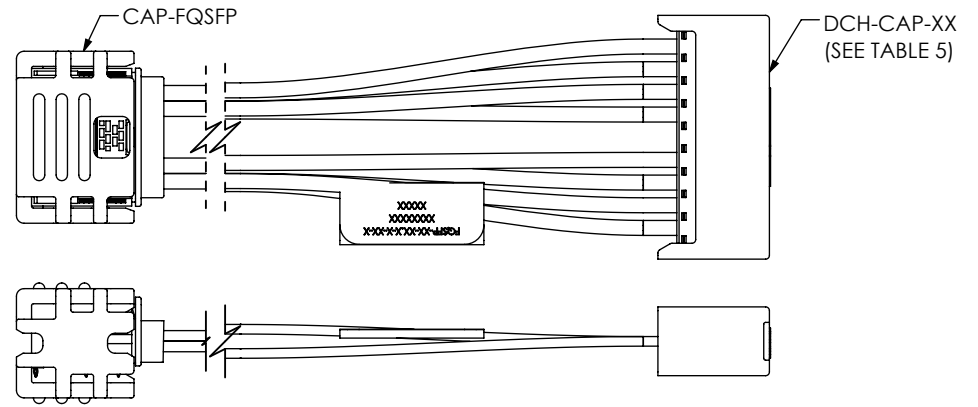

PACKAGING VIEW

TABLE 5		
END OPTION	PART NUMBER	QTY
1	DCH-CAP-08	1
2	DCH-CAP-04	2

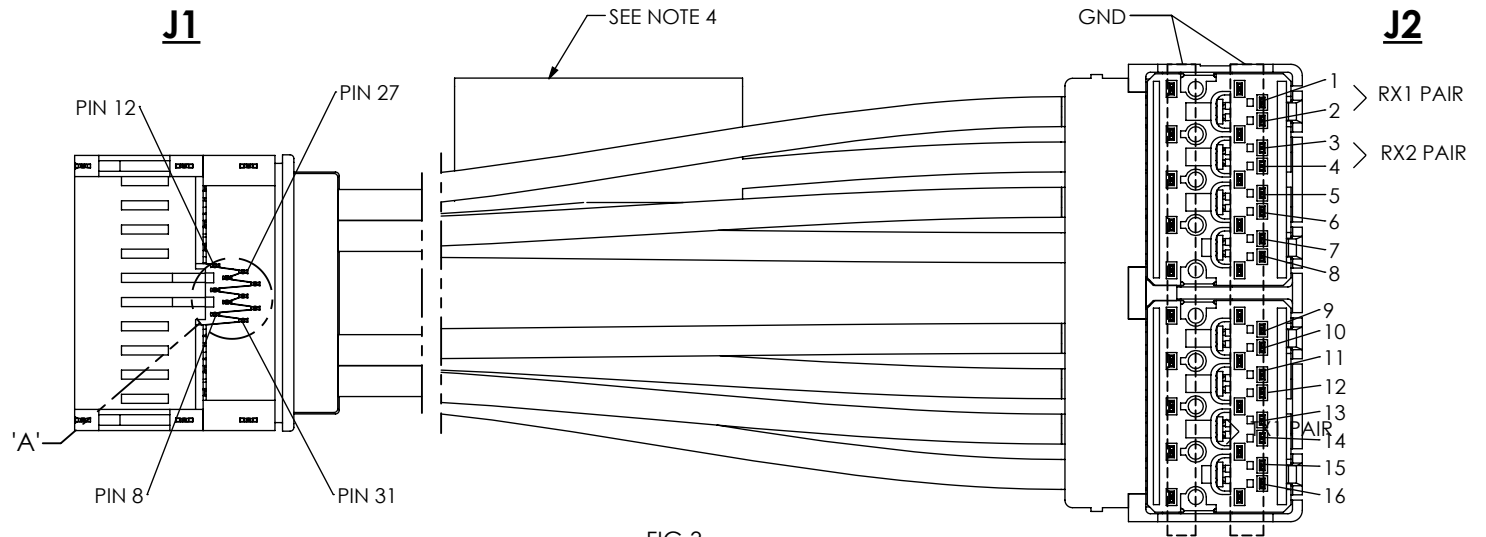
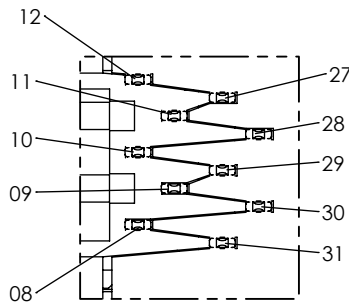

FIG 3
SIGNAL MAP
BOTTOM VIEW SHOWN



DETAIL 'A'
SCALE 6 : 1

PROPRIETARY NOTE
THIS DOCUMENT CONTAINS CONFIDENTIAL AND
PROPRIETARY INFORMATION AND ALL DESIGN,
MANUFACTURING, REPRODUCTION, USE, PATENT RIGHTS
AND SALES RIGHTS ARE EXPRESSLY RESERVED BY SAMTEC,
INC. THIS DOCUMENT SHALL NOT BE DISCLOSED, IN WHOLE
OR PART, TO ANY UNAUTHORIZED PERSON OR ENTITY NOR
REPRODUCED, TRANSFERRED OR INCORPORATED IN ANY
OTHER PROJECT IN ANY MANNER WITHOUT THE EXPRESS
WRITTEN CONSENT OF SAMTEC, INC.

DO NOT SCALE DRAWING

SHEET SCALE: 2:1



520 PARK EAST BLVD, NEW ALBANY, IN 47150
PHONE: 812-944-6733 FAX: 812-948-5047
e-Mail: info@SAMTEC.com code 55322

DESCRIPTION: QSF FLYOVER CABLE ASSEMBLY

DWG. NO. FQSFP-XX-XX.X-X-XX-X

BY: D.SCHMELZ 03/20-2015 SHEET 2 OF 8

TABLE 2
SIGNAL MAPPING

J1	NAME	J2	J1	NAME	J3
13	GND2	GND2	1	GND1	GND1
14	RX3p	6	2	TX2n	6
15	RX3n	5	3	TX2p	5
16	GND2	GND2	4	GND1	GND1
17	RX1p	2	5	TX4n	2
18	RX1n	1	6	TX4p	1
19	GND2	GND2	7	GND1	GND1
20	GND2	GND2	32	GND1	GND1
21	RX2n	3	33	TX3p	3
22	RX2p	4	34	TX3n	4
23	GND2	GND2	35	GND1	GND1
24	RX4n	7	36	TX1p	7
25	RX4p	8	37	TX1n	8
26	GND2	GND2	38	GND1	GND1

WITHIN THIS CABLE ASSEMBLY, POSITIONS LABELED WITH A SPECIFIC GND# ARE COMMON AND TIED TO TWINAX SHIELD

ON THE MATING BOARD ASSEMBLY, SAMTEC RECOMMENDS IMPLEMENTING A COMMON GND REFERENCE TYING ALL GND#'s TOGETHER

J1	NAME	J2	J1	NAME	J3
27	ModPRsL	NC	8	ModeselL	NC
28	IntL	NC	9	ResetL	NC
29	VxxTx	NC	10	VccRx	NC
30	Vcc1	NC	11	SCL	NC
31	LPMode	NC	12	SDA	NC

ALL NC ARE ROUTED VIA COMPLIANT TAILS TO THE PCB

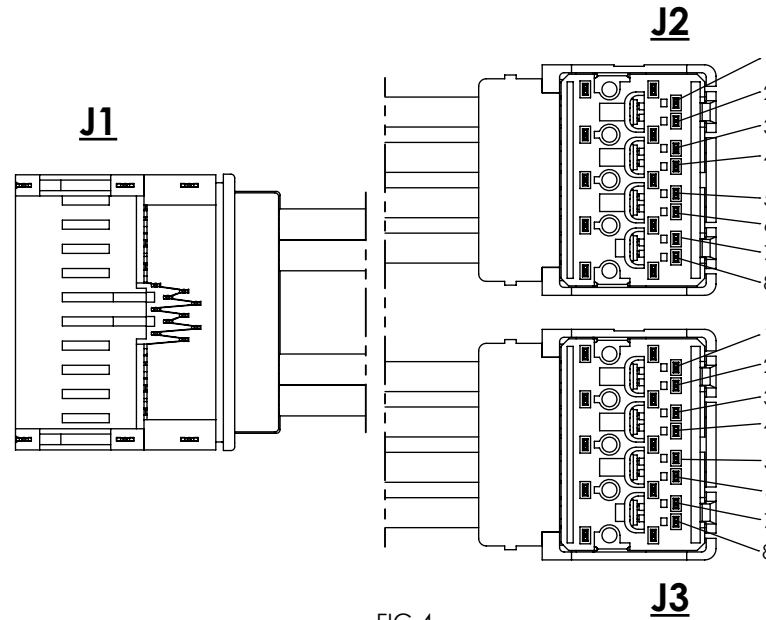

FIG 4
SIGNAL MAP
BOTTOM VIEW SHOWN
SAME AS FIG 3 EXCEPT AS SHOWN

PROPRIETARY NOTE

THIS DOCUMENT CONTAINS CONFIDENTIAL AND PROPRIETARY INFORMATION AND ALL DESIGN, MANUFACTURING, REPRODUCTION, USE, PATENT RIGHTS AND SALES RIGHTS ARE EXPRESSLY RESERVED BY SAMTEC, INC. THIS DOCUMENT SHALL NOT BE DISCLOSED, IN WHOLE OR PART, TO ANY UNAUTHORIZED PERSON OR ENTITY NOR REPRODUCED, TRANSFERRED OR INCORPORATED IN ANY OTHER PROJECT IN ANY MANNER WITHOUT THE EXPRESS WRITTEN CONSENT OF SAMTEC, INC.



520 PARK EAST BLVD, NEW ALBANY, IN 47150
PHONE: 812-944-6733 FAX: 812-948-5047
e-Mail: info@SAMTEC.com code 55322

DO NOT SCALE DRAWING

SHEET SCALE: 2:1

DESCRIPTION: QSFY FLYOVER CABLE ASSEMBLY

DWG. NO. FQSFP-XX-XX.X-X-XX-X

BY: D.SCHMELZ 03/20-2015 SHEET 3 OF 8

TABLE 3		
SIGNAL MAPPING		
J1	NAME	J2
1	GND	GND
2	TX2n	B2
3	TX2p	B3
4	GND	GND
5	TX4n	B5
6	TX4p	B6
7	GND	GND
13	GND	GND
14	RX3p	B14
15	RX3n	B15
16	GND	GND
17	RX1p	B17
18	RX1n	B18
19	GND	GND
20	GND	GND
21	RX2n	A18
22	RX2p	A17
23	GND	GND
24	RX4n	A15
25	RX4p	A14
26	GND	GND
32	GND	GND
33	TX3p	A6
34	TX3n	A5
35	GND	GND
36	TX1p	A3
37	TX1n	A2
38	GND	GND
ALL GROUNDS COMMON AND TIED TO CABLE		
ALL OMITTED J2 PIN NUMBERS ARE TIED TO GROUND		
J1	NAME	J2
8	ModSel	NC
9	Reset	NC
10	VccRx	NC
11	SCL	NC
12	SDA	NC
27	ModPrs	NC
28	IntL	NC
29	VxxTx	NC
30	Vcc1	NC
31	LPMode	NC
ALL NC ARE ROUTED VIA COMPLIANT TAILS TO THE PCB		

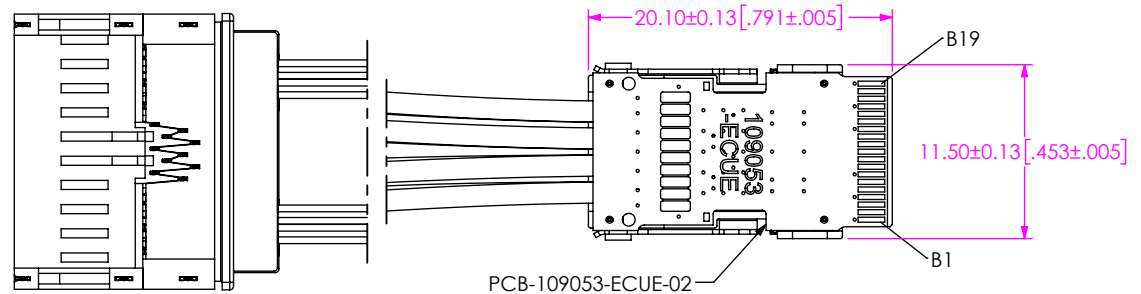
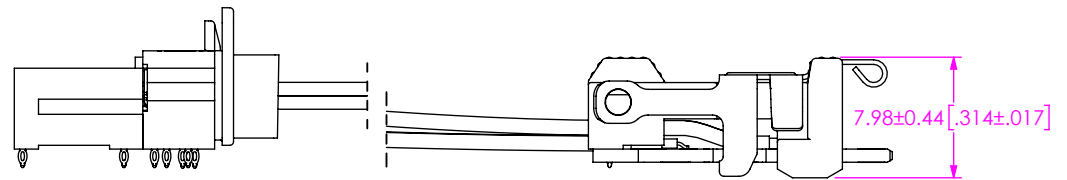
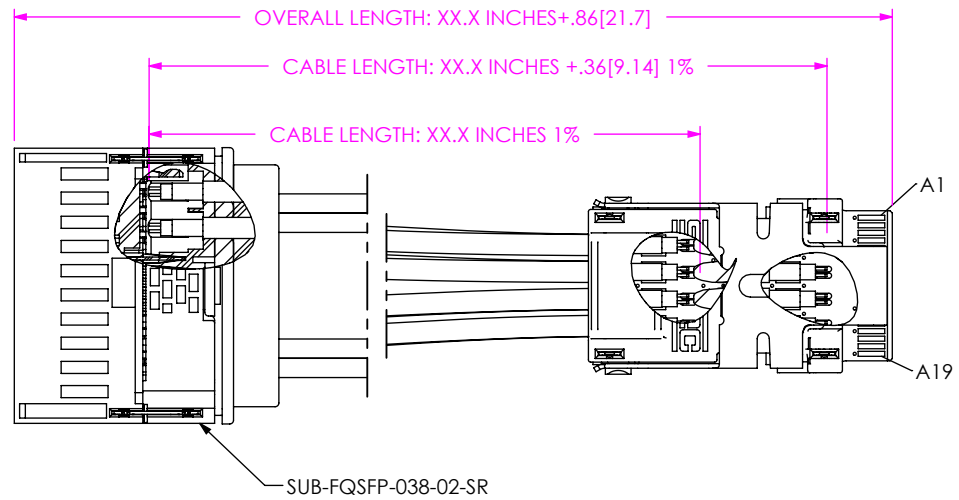
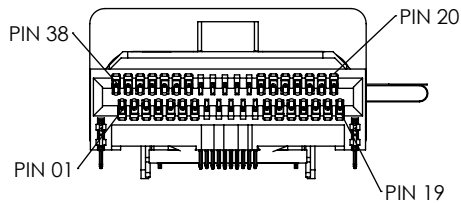

FIG 5
FQSFP-01-XX.X-L-PF-3 SHOWN
(SAME AS FIG 1 & 3 EXCEPT AS SHOWN)

PROPRIETARY NOTE
THIS DOCUMENT CONTAINS CONFIDENTIAL AND PROPRIETARY INFORMATION AND ALL DESIGN, MANUFACTURING, REPRODUCTION, USE, PATENT RIGHTS AND SALES RIGHTS ARE EXPRESSLY RESERVED BY SAMTEC, INC. THIS DOCUMENT SHALL NOT BE DISCLOSED, IN WHOLE OR PART, TO ANY UNAUTHORIZED PERSON OR ENTITY NOR REPRODUCED, TRANSFERRED OR INCORPORATED IN ANY OTHER PROJECT IN ANY MANNER WITHOUT THE EXPRESS WRITTEN CONSENT OF SAMTEC, INC.



520 PARK EAST BLVD, NEW ALBANY, IN 47150
PHONE: 812-944-6733 FAX: 812-948-5047
e-Mail: info@SAMTEC.com code 55322

DO NOT SCALE DRAWING

SHEET SCALE: 2:1

DESCRIPTION: QSFY FLYOVER CABLE ASSEMBLY

DWG. NO. FQSFP-XX-XX.X-X-XX-X

BY: D.SCHMELZ 03/20-2015 SHEET 4 OF 8

TABLE 4 SIGNAL MAPPING		
J1	NAME	J2
1	GND1	GND1
2	TX2n	12
3	TX2p	10
4	GND1	GND1
5	TX4n	6
6	TX4p	4
7	GND1	GND1
13	GND2	GND2
14	RX3p	11
15	RX3n	9
16	GND2	GND2
17	RX1p	5
18	RX1n	3
19	GND2	GND2
20	GND2	GND2
21	RX2n	15
22	RX2p	17
23	GND2	GND2
24	RX4n	21
25	RX4p	23
26	GND2	GND2
32	GND1	GND1
33	TX3p	16
34	TX3n	18
35	GND1	GND1
36	TX1p	22
37	TX1n	24
38	GND1	GND1
<p>WITHIN THIS CABLE ASSEMBLY, POSITIONS LABELED WITH A SPECIFIC GND# ARE COMMON AND TIED TO TWINAX SHIELD</p>		
<p>ON THE MATING BOARD ASSEMBLY, SAMTEC RECOMMENDS IMPLEMENTING A COMMON GND REFERENCE TYING ALL GND#'s TOGETHER</p>		
J1	NAME	J2
8	ModselL	NC
9	ResetL	NC
10	VccRx	NC
11	SCL	NC
12	SDA	NC
27	ModPrsL	NC
28	IntL	NC
29	VxxTx	NC
30	Vcc1	NC
31	LPMode	NC
<p>ALL NC ARE ROUTED VIA COMPLIANT TAILS TO THE PCB</p>		

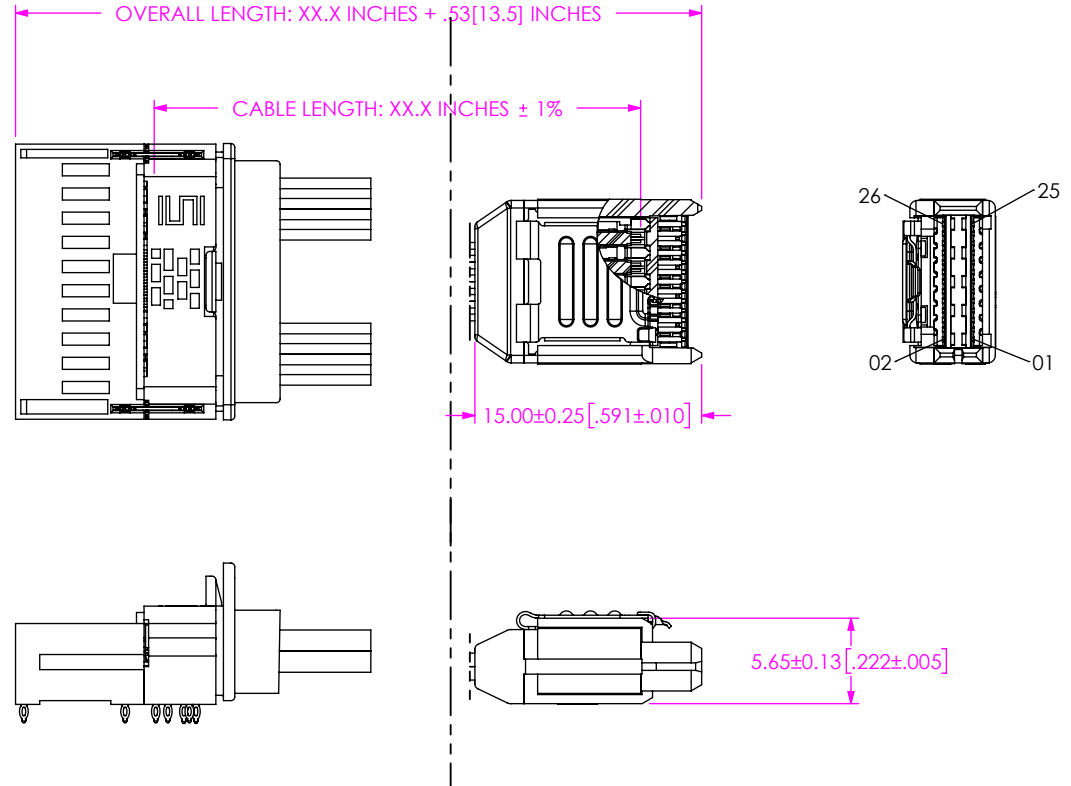

FIG 16
 FQSFP-01-XX.X-L-PF-4 SHOWN
 (SAME AS FIG 1 & 3 EXCEPT AS SHOWN)

PROPRIETARY NOTE
 THIS DOCUMENT CONTAINS CONFIDENTIAL AND PROPRIETARY INFORMATION AND ALL DESIGN, MANUFACTURING, REPRODUCTION, USE, PATENT RIGHTS AND SALES RIGHTS ARE EXPRESSLY RESERVED BY SAMTEC, INC. THIS DOCUMENT SHALL NOT BE DISCLOSED, IN WHOLE OR PART, TO ANY UNAUTHORIZED PERSON OR ENTITY NOR REPRODUCED, TRANSFERRED OR INCORPORATED IN ANY OTHER PROJECT IN ANY MANNER WITHOUT THE EXPRESS WRITTEN CONSENT OF SAMTEC, INC.

samtec
 520 PARK EAST BLVD, NEW ALBANY, IN 47150
 PHONE: 812-944-6733 FAX: 812-948-5047
 e-Mail info@SAMTEC.com code 55322

DO NOT SCALE DRAWING
 SHEET SCALE: 1:1

DESCRIPTION:
 QSFP FLYOVER CABLE ASSEMBLY

DWG. NO.
 FQSFP-XX-XX.X-X-XX-X

BY: D.SCHMELZ 03/20-2015 SHEET 5 OF 8

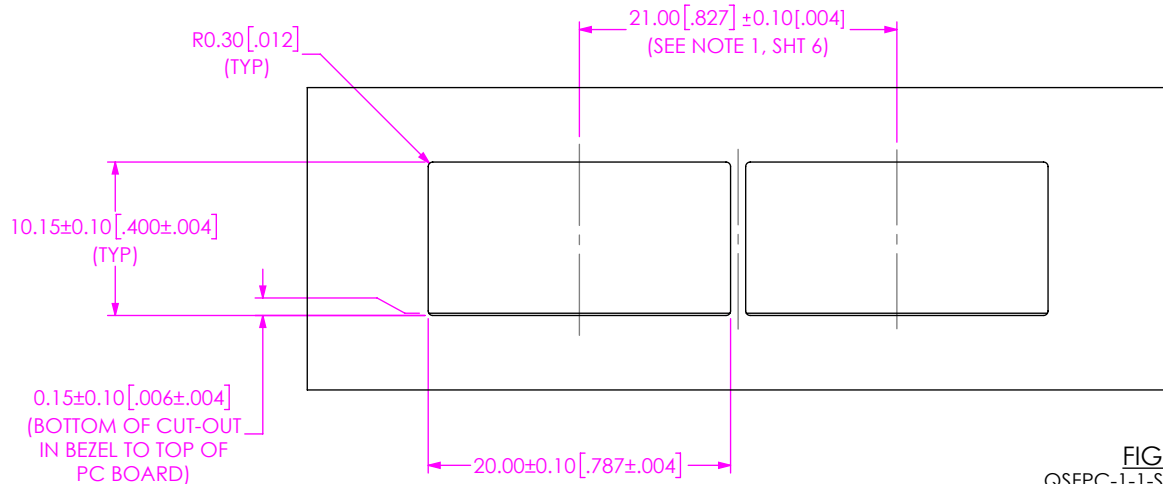

FIG 6
QSFP-1-1-S-F SHOWN

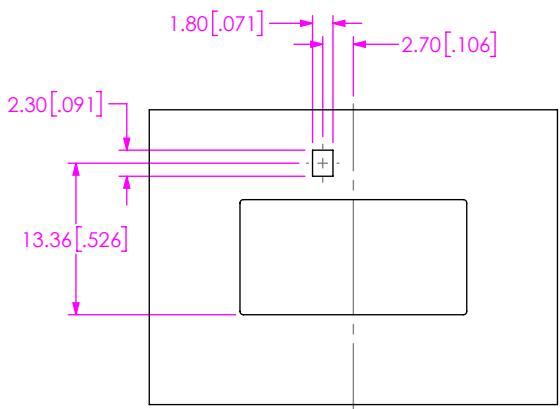
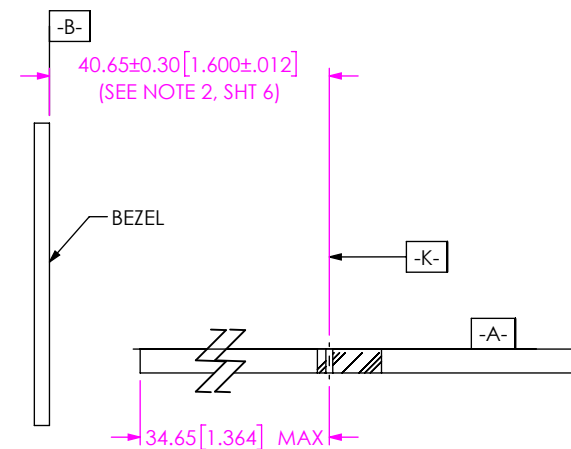

FIG 7
QSFP-1-X-S-LP-F WITH FQSFP-LP-01 SHOWN
(1 LIGHTPIPE)
(DIFFERENT AS SHOWN, OTHERWISE SAME AS FIG 6)

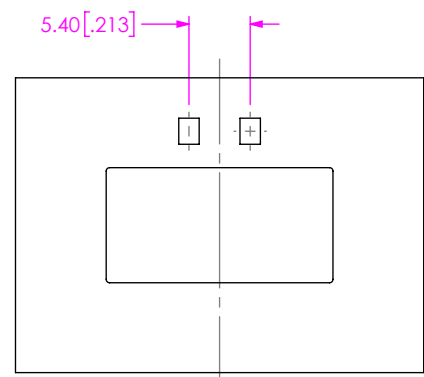

FIG 8
QSFP-1-X-S-LP-F WITH FQSFP-LP-02 SHOWN
(2 LIGHTPIPES)
(DIFFERENT AS SHOWN, OTHERWISE SAME AS FIG 7)

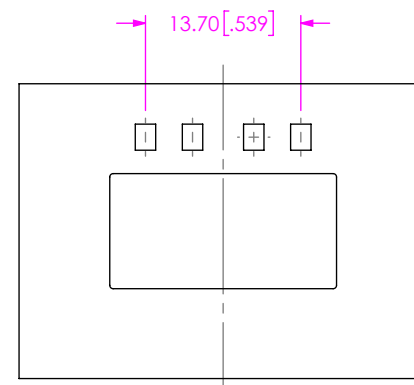
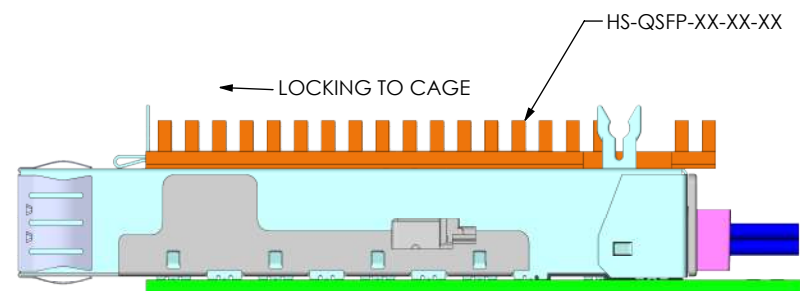
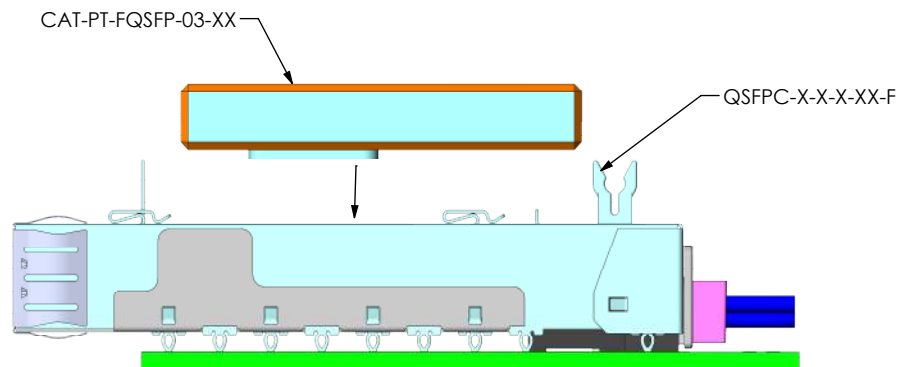
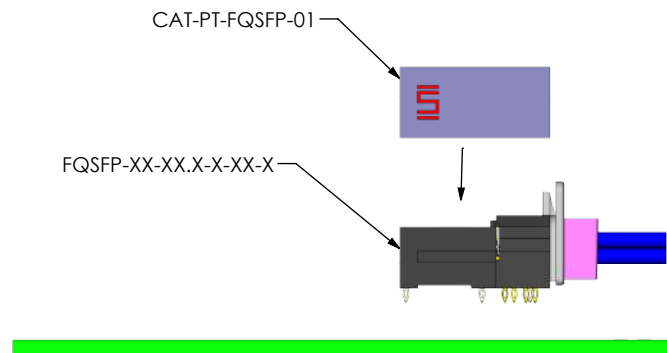
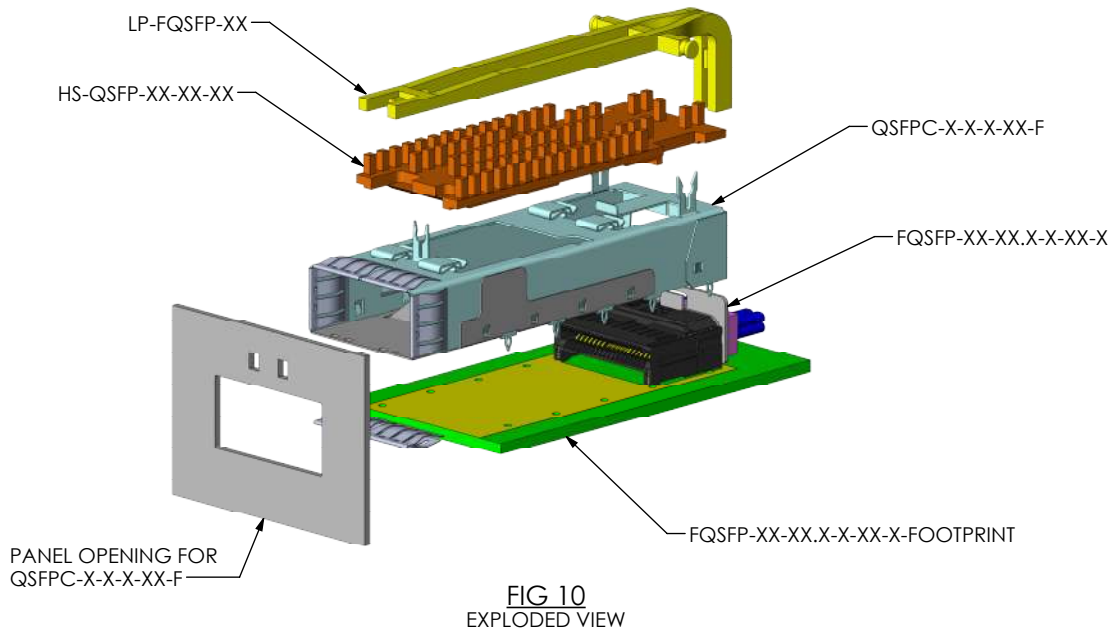

FIG 9
QSFP-1-X-S-LP-F WITH FQSFP-LP-04 SHOWN
(4 LIGHTPIPES)
(DIFFERENT AS SHOWN, OTHERWISE SAME AS FIG 8)

- PANEL NOTES:
1. MINIMUM PITCH DIMENSION FOR INDIVIDUAL GAGES.
 2. DIMENSION BASELINE IS DATUM -K-.
 3. NOT RECOMMENDED FOR PCI APPLICATIONS.

PROPRIETARY NOTE
THIS DOCUMENT CONTAINS CONFIDENTIAL AND PROPRIETARY INFORMATION AND ALL DESIGN, MANUFACTURING, REPRODUCTION, USE, PATENT RIGHTS AND SALES RIGHTS ARE EXPRESSLY RESERVED BY SAMTEC, INC. THIS DOCUMENT SHALL NOT BE DISCLOSED, IN WHOLE OR PART, TO ANY UNAUTHORIZED PERSON OR ENTITY NOR REPRODUCED, TRANSFERRED OR INCORPORATED IN ANY OTHER PROJECT IN ANY MANNER WITHOUT THE EXPRESS WRITTEN CONSENT OF SAMTEC, INC.





PROPRIETARY NOTE
THIS DOCUMENT CONTAINS CONFIDENTIAL AND PROPRIETARY INFORMATION AND ALL DESIGN, MANUFACTURING, REPRODUCTION, USE, PATENT RIGHTS AND SALES RIGHTS ARE EXPRESSLY RESERVED BY SAMTEC, INC. THIS DOCUMENT SHALL NOT BE DISCLOSED, IN WHOLE OR PART, TO ANY UNAUTHORIZED PERSON OR ENTITY NOR REPRODUCED, TRANSFERRED OR INCORPORATED IN ANY OTHER PROJECT IN ANY MANNER WITHOUT THE EXPRESS WRITTEN CONSENT OF SAMTEC, INC.

samtec
520 PARK EAST BLVD, NEW ALBANY, IN 47150
PHONE: 812-944-6733 FAX: 812-948-5047
e-Mail info@SAMTEC.com code 55322

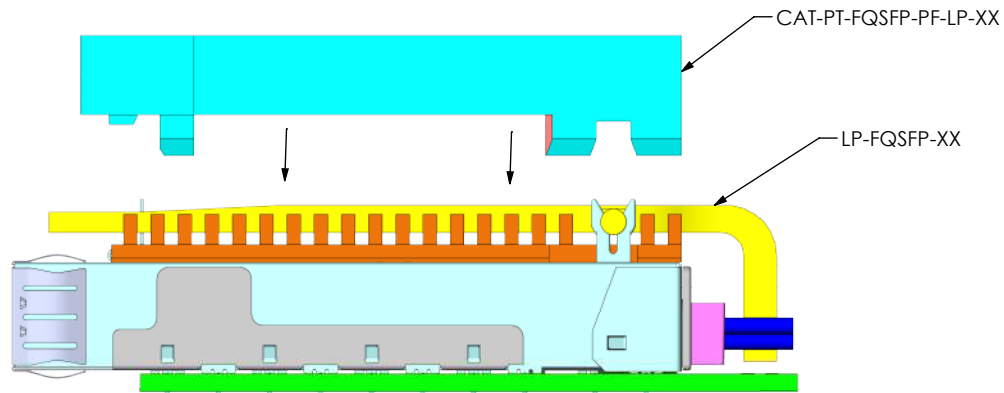
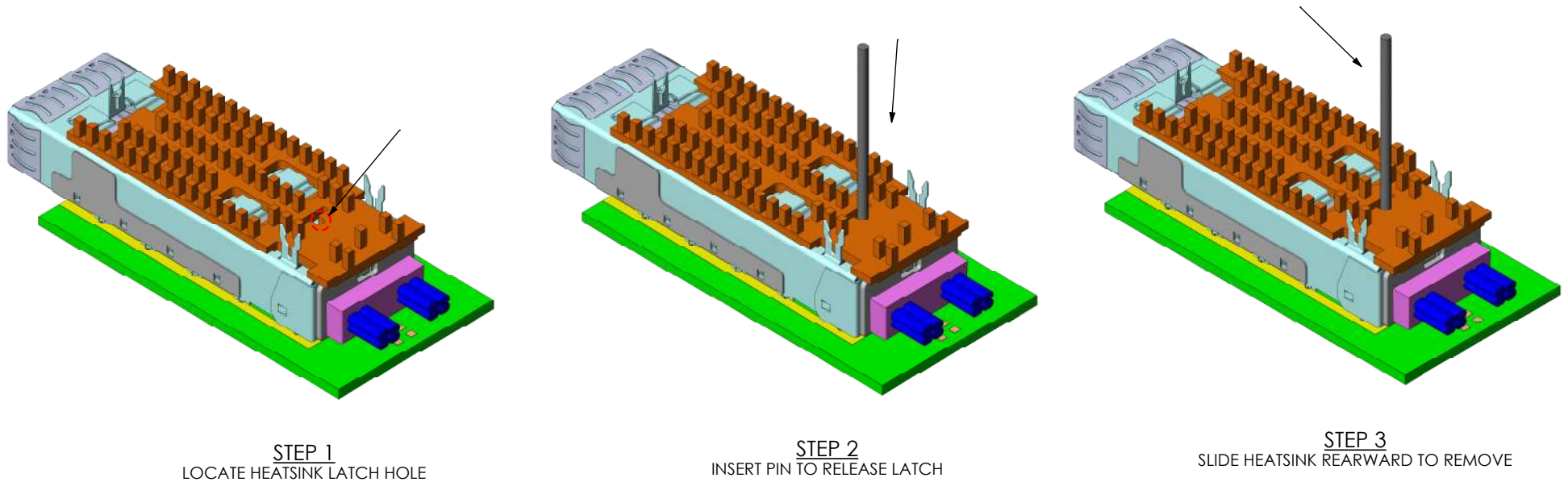

FIG 14
PRESSING LIGHT PIPE TO CAGE



STEP 1
LOCATE HEATSINK LATCH HOLE

STEP 2
INSERT PIN TO RELEASE LATCH

STEP 3
SLIDE HEATSINK REARWARD TO REMOVE

FIG 15
HEAT SINK REMOVAL