

ISO VIEW (参考)

13.5	12.5	15.1	51281-2694	26
12.5	11.5	14.1	51281-2494	24
11.5	10.5	13.1	51281-2294	22
10.5	9.5	12.1	51281-2094	20
9.5	8.5	11.1	51281-1894	18
8.5	7.5	10.1	51281-1694	16
7.5	6.5	9.1	51281-1494	14
6.5	5.5	8.1	51281-1294	12
6.0	5.0	7.6	51281-1194	11
5.5	4.5	7.1	51281-1094	10
5.0	4.0	6.6	51281-0994	9
4.5	3.5	6.1	51281-0894	8
4.0	3.0	5.6	51281-0794	7
3.5	2.5	5.1	51281-0694	6
3.0	2.0	4.6	51281-0594	5
C	B	A	EMBOSSED TAPE	CIRCUIT
			ORDER No. オーダー番号	

CONNECTOR SERIES NO. : 51281-**40

REVISED EC NO: J2011-0538 DRWN: TONO 2010/10/12 CHKD: HIJIMA 2010/10/12 APPR: KMORIKAWA 2010/10/13	GENERAL TOLERANCES (UNLESS SPECIFIED)		DIMENSION STYLE	SCALE	DESIGN UNITS	THIRD ANGLE PROJECTION	
			MM ONLY	---	METRIC		
	10 UNDER	±0.2	DRAWN BY	DATE	TITLE	0.5 FPC CONN NON-ZIF HSG ASSY (HGT=1.2MM)	
	10 OVER 30 UNDER	±0.25	KENSUZUKI	2004/10/19			
30 OVER	±0.3	CHECKED BY	DATE		MOLEX INCORPORATED		
ANGULAR	±3 °	NUKITA	2004/10/19				
DRAFT WHERE APPLICABLE MUST REMAIN WITHIN DIMENSIONS		APPROVED BY	DATE	DOCUMENT NO.		SHEET NO.	
		KMORIKAWA	2010/10/13	SD-51281-011		1 OF 2	
J	REV	SEE TABLE		THIS DRAWING CONTAINS INFORMATION THAT IS PROPRIETARY TO MOLEX INCORPORATED AND SHOULD NOT BE USED WITHOUT WRITTEN PERMISSION			

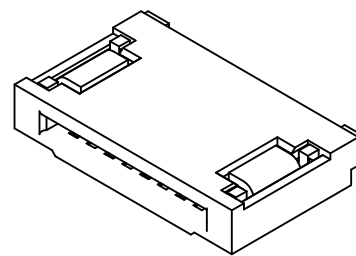
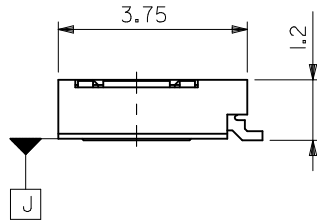
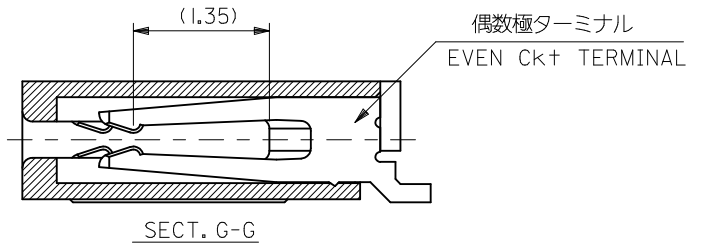
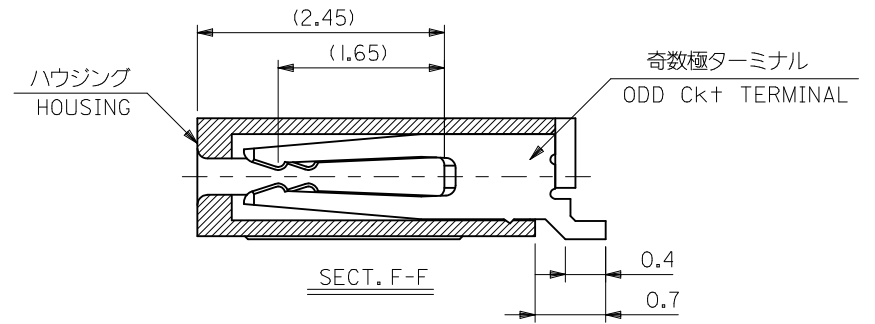
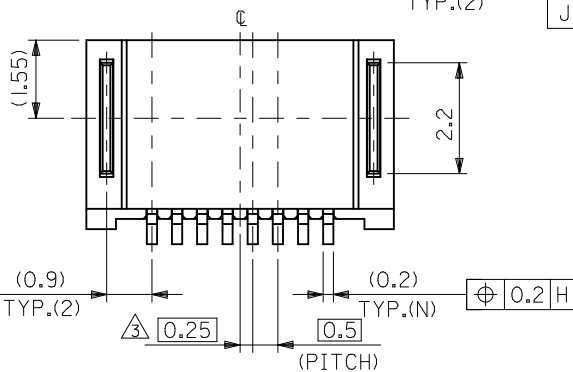
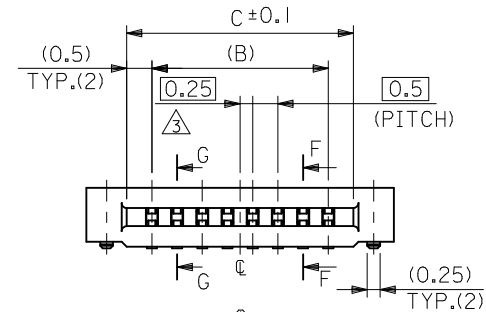
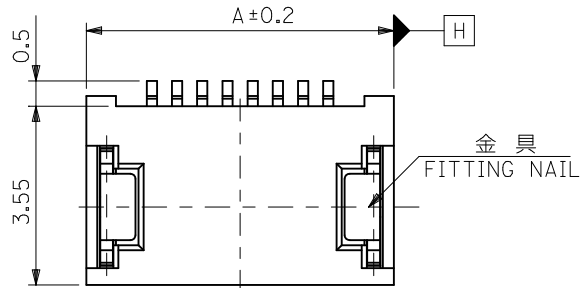

ISO VIEW (参考)

13.5	12.5	15.1	51281-2694	26
12.5	11.5	14.1	51281-2494	24
11.5	10.5	13.1	51281-2294	22
10.5	9.5	12.1	51281-2094	20
9.5	8.5	11.1	51281-1894	18
8.5	7.5	10.1	51281-1694	16
7.5	6.5	9.1	51281-1494	14
6.5	5.5	8.1	51281-1294	12
6.0	5.0	7.6	51281-1194	11
5.5	4.5	7.1	51281-1094	10
5.0	4.0	6.6	51281-0994	9
4.5	3.5	6.1	51281-0894	8
4.0	3.0	5.6	51281-0794	7
3.5	2.5	5.1	51281-0694	6
3.0	2.0	4.6	51281-0594	5

C	B	A	EMBOSSED TAPE	CIRCUIT
			ORDER No. オーダー番号	

CONNECTOR SERIES NO. : 51281-**40

REVISED EC NO: J2011-0538 DRWN: TONO 2010/10/12 CHKD: HIJIMA 2010/10/12 APPR: KMORIKAWA 2010/10/13	GENERAL TOLERANCES (UNLESS SPECIFIED)		DIMENSION STYLE	SCALE	DESIGN UNITS	THIRD ANGLE PROJECTION	
			MM ONLY	---	METRIC		
	10 UNDER	±0.2	DRAWN BY	DATE	TITLE	0.5 FPC CONN NON-ZIF HSG ASSY (HGT=1.2MM)	
	10 OVER 30 UNDER	±0.25	KENSUZUKI	2004/10/19			
30 OVER	±0.3	CHECKED BY	DATE		MOLEX INCORPORATED		
ANGULAR	±3 °	NUKITA	2004/10/19				
DRAFT WHERE APPLICABLE MUST REMAIN WITHIN DIMENSIONS		APPROVED BY	DATE	DOCUMENT NO.		SHEET NO.	
		KMORIKAWA	2010/10/13	SD-51281-011		1 OF 2	
J	REV	SEE TABLE		THIS DRAWING CONTAINS INFORMATION THAT IS PROPRIETARY TO MOLEX INCORPORATED AND SHOULD NOT BE USED WITHOUT WRITTEN PERMISSION			

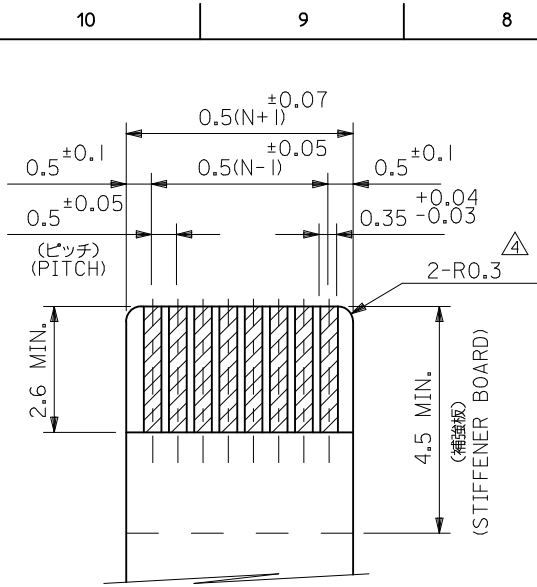

適合FPC推奨寸法
APPLICABLE FPC
RECOMMENDED DIMENSION
(仕上がり厚さ: 0.3 ±0.03)
(THICKNESS: 0.3 ±0.03)

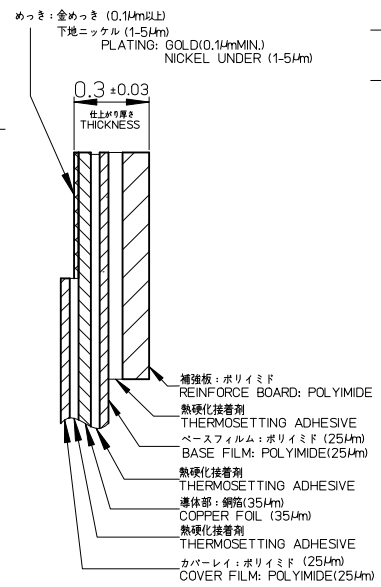

FPC構成推奨仕様
STRUCTURE OF FPC

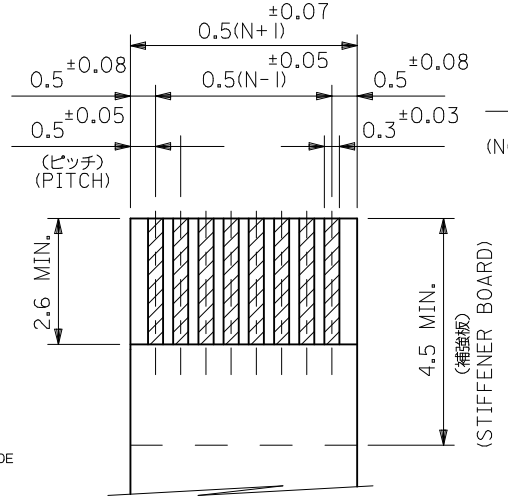

適合FFC推奨寸法
APPLICABLE FFC
RECOMMENDED DIMENSION
(仕上がり厚さ: 0.3 ±0.03)
(THICKNESS: 0.3 ±0.03)

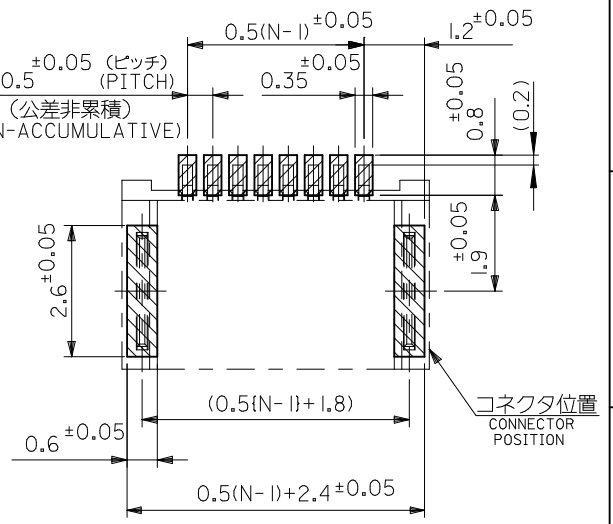

参考基板レイアウト図
RECOMMENDED P.C. BOARD LAYOUT
(マウント面)
(MOUNTING SIDE)

注記 NOTES

- 使用材料 MATERIAL
ハウジング : 液晶ポリマー ガラス充填 UL94V-0
HOUSING : LIQUID CRYSTAL POLYMER (GLASS FILLED) UL94V-0
ターミナル : リン青銅 (t=0.2), ニッケル下地
CONTACT部: 金メッキ
テール部: 錫メッキ
TERMINAL : PHOSPHOR-BRONZE, TAIL : TIN CONTACT : GOLD OVER NICKEL PLATING
金具 : リン青銅 (t=0.25), ニッケル下地 純錫メッキ
FITTING NAIL : PHOSPHOR-BRONZE, PURE-TIN OVER NICKEL PLATING.
- △ ソルダーテール半田付け面のズレ量、及び金具半田付け面のズレ量は、基準面 □ に対し、上方向 0.1 MAXIMUM 下方向 0.15 MAXIMUM とする。又、相互のバラツキ量は 0.1 MAXIMUM とする。
MISALIGNMENT OF SOLDER TAILS AND FITTING NAILS FROM □ UPPER DIRECTION : 0.1 MAXIMUM, LOWER DIRECTION : 0.15 MAXIMUM. OFFSET BETWEEN SOLDER TAILS AND FITTING NAILS : 0.1 MAXIMUM.
- △ 偶数極に適用。
TO BE APPLIED ONLY WHEN ALL CIRCUIT ARE EVEN.
- △ R0.3は、FPCの導体部にかからないこと。
R0.3 MUST NOT BE OVERLAPPED TO PATTERN OF FPC.
- FPC/FFCについて:
打抜き方向は導体側から補強板側を推奨いたします。
導体部については軟銅箔35μmまたは50μm
メッキ厚 0.1μm 以上 金メッキ (電気メッキ)
を推奨いたします。
RECOMMENDED PUNCHER DIRECTION :
FROM CONDUCTOR SIDE TO STIFFENER BOARD SIDE.
RECOMMENDED CONDUCTOR SPEC :
THICKNESS OF SOFT COPPER FOIL : 35 μm or 50 μm
GOLD PLATING : 0.1 μm MIN. (ELECTRICAL PLATING)

6. 本製品は51281-**-**20の鉛フリー品である。
THIS PRODUCT IS LEAD FREE OF 51281-**-**20.
7. ソルダーテールの平坦度は、0.1 MAXIMUMとする。
SOLDER TAIL COPLANARITY IS 0.1 MAXIMUM.
8. ELV 及び RoHS 適合品。
ELV AND RoHS COMPLIANT.

REVISED EC NO: J2011-0538 DRWN: TONO CHKD: HIJIMA APP: KIMORIKAWA 2010/10/12 2010/10/12 2010/10/13	DESCRIPTION	GENERAL TOLERANCES (UNLESS SPECIFIED)		DIMENSION STYLE MM ONLY		SCALE ---	DESIGN UNITS METRIC	THIRD ANGLE PROJECTION	
		10 UNDER ±0.2	10 OVER 30 UNDER ±0.25	30 OVER ±0.3	ANGULAR ±3 °	DRAFT WHERE APPLICABLE MUST REMAIN WITHIN DIMENSIONS	DRAWN BY DATE TITLE KENSUZUKI 2004/10/19 0.5 FPC CONN NON-ZIF HSG ASSY (HGT=1.2MM)		
		CHECKED BY DATE NUKITA 2004/10/19		APPROVED BY DATE KMORIKAWA 2010/10/13		MATERIAL NO. SHEET NO. SEE SHEET 1 OF 2 2 OF 2		DOCUMENT NO. SD-51281-011	
		SIZE A3		THIS DRAWING CONTAINS INFORMATION THAT IS PROPRIETARY TO MOLEX INCORPORATED AND SHOULD NOT BE USED WITHOUT WRITTEN PERMISSION					

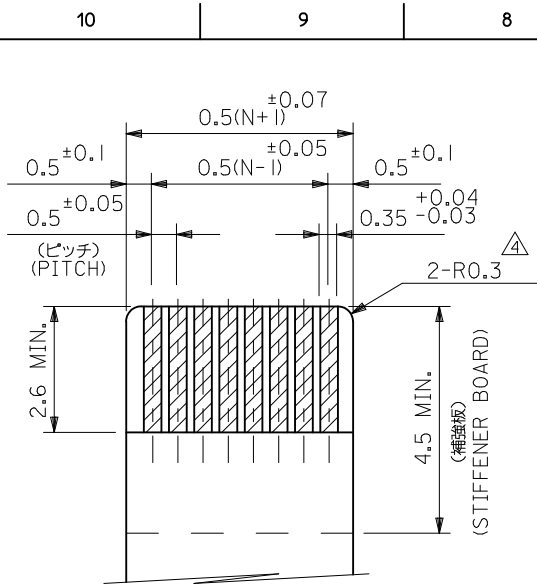

適合FPC推奨寸法
APPLICABLE FPC
RECOMMENDED DIMENSION
(仕上がり厚さ: 0.3 ±0.03)
(THICKNESS: 0.3 ±0.03)

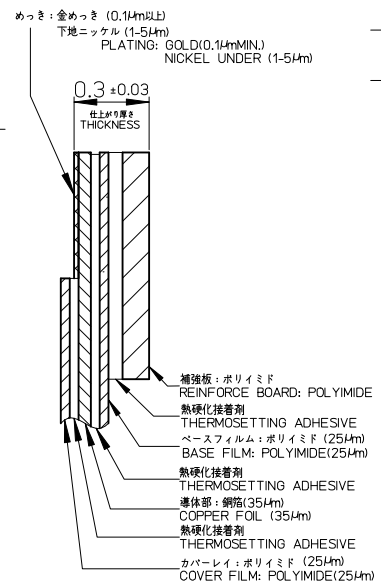

FPC構成推奨仕様
STRUCTURE OF FPC

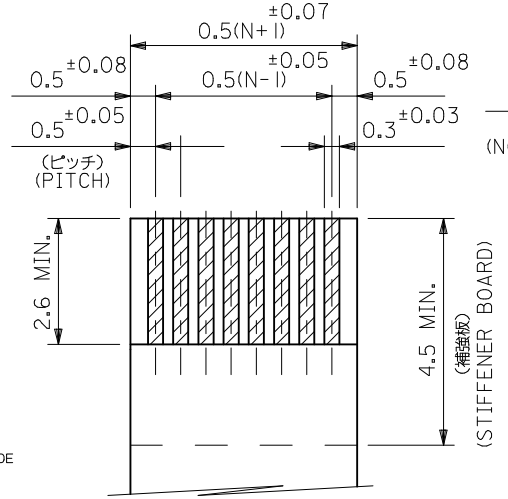

適合FFC推奨寸法
APPLICABLE FFC
RECOMMENDED DIMENSION
(仕上がり厚さ: 0.3 ±0.03)
(THICKNESS: 0.3 ±0.03)

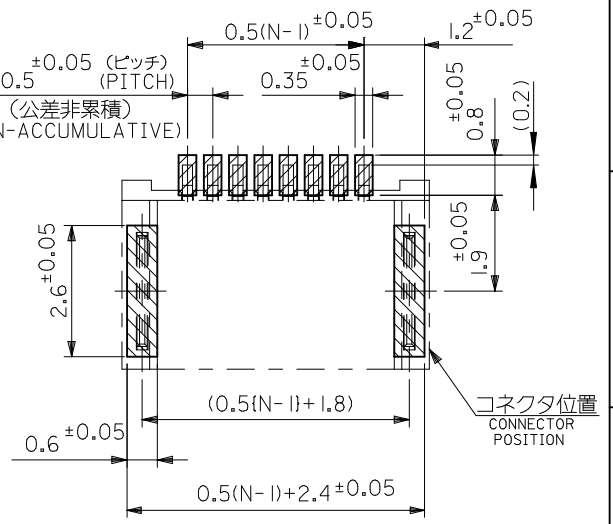

参考基板レイアウト図
RECOMMENDED P.C. BOARD LAYOUT
(マウント面)
(MOUNTING SIDE)

注記 NOTES

- 使用材料 MATERIAL
ハウジング : 液晶ポリマー ガラス充填 UL94V-0
HOUSING : LIQUID CRYSTAL POLYMER (GLASS FILLED) UL94V-0
ターミナル : リン青銅 (t=0.2), ニッケル下地
CONTACT部: 金メッキ
テール部: 錫メッキ
TERMINAL : PHOSPHOR-BRONZE , TAIL : TIN CONTACT : GOLD OVER NICKEL PLATING
金具 : リン青銅 (t=0.25), ニッケル下地 純錫メッキ
FITTING NAIL : PHOSPHOR-BRONZE , PURE-TIN OVER NICKEL PLATING.
- △ ソルダーテール半田付け面のズレ量、及び金具半田付け面のズレ量は、基準面 □ に対し、上方向 0.1 MAXIMUM 下方向 0.15 MAXIMUM とする。
又、相互のバラツキ量は 0.1 MAXIMUM とする。
MISALIGNMENT OF SOLDER TAILS AND FITTING NAILS FROM □
UPPER DIRECTION : 0.1 MAXIMUM , LOWER DIRECTION : 0.15 MAXIMUM.
OFFSET BETWEEN SOLDER TAILS AND FITTING NAILS : 0.1 MAXIMUM.
- △ 偶数極に適用。
TO BE APPLIED ONLY WHEN ALL CIRCUIT ARE EVEN.
- △ R0.3は、FPCの導体部にかからないこと。
R0.3 MUST NOT BE OVERLAPPED TO PATTERN OF FPC.
- FPC/FFCについて:
打抜き方向は導体側から補強板側を推奨いたします。
導体部については軟銅箔35μmまたは50μm
メッキ厚 0.1μm 以上 金メッキ (電気メッキ)
を推奨いたします。
RECOMMENDED PUNCHER DIRECTION :
FROM CONDUCTOR SIDE TO STIFFENER BOARD SIDE.
RECOMMENDED CONDUCTOR SPEC :
THICKNESS OF SOFT COPPER FOIL : 35 μm or 50 μm
GOLD PLATING : 0.1 μm MIN. (ELECTRICAL PLATING)

6. 本製品は51281-**-20の鉛フリー品である。
THIS PRODUCT IS LEAD FREE OF 51281-**-20.
7. ソルダーテールの平坦度は、0.1 MAXIMUMとする。
SOLDER TAIL COPLANARITY IS 0.1 MAXIMUM.
8. ELV 及び RoHS 適合品。
ELV AND RoHS COMPLIANT.

REVISED EC NO: J2011-0538 DRWN: TONO CHKD: HIJIMA APP: K.MORIKAWA 2010/10/12 2010/10/12 2010/10/13	DESCRIPTION	GENERAL TOLERANCES (UNLESS SPECIFIED)		DIMENSION STYLE MM ONLY		SCALE ---	DESIGN UNITS METRIC	THIRD ANGLE PROJECTION	
		10 UNDER	±0.2	DRAWN BY KENSUZUKI	DATE 2004/10/19	TITLE 0.5 FPC CONN NON-ZIF HSG ASSY (HGT=1.2MM)			
		10 OVER 30 UNDER	±0.25	CHECKED BY NUKITA	DATE 2004/10/19	MOLEX INCORPORATED			
		30 OVER	±0.3	APPROVED BY KMORIKAWA	DATE 2010/10/13				
ANGULAR	±3 °	MATERIAL NO. SEE SHEET 1 OF 2	DOCUMENT NO. SD-51281-011	SHEET NO. 2 OF 2					
DRAFT WHERE APPLICABLE MUST REMAIN WITHIN DIMENSIONS		SIZE A3	THIS DRAWING CONTAINS INFORMATION THAT IS PROPRIETARY TO MOLEX INCORPORATED AND SHOULD NOT BE USED WITHOUT WRITTEN PERMISSION						

NOTES

- 製品詳細寸法については図面 SD-51281-011 を参照下さい。
RE DETAILED DIMENSION, SEE SD-51281-011
- 梱包数量：3000個/リール
NUMBER OF CONNECTORS : 3000PCS/REEL
- リードテープ長さ LEAD TAPE LENGTH

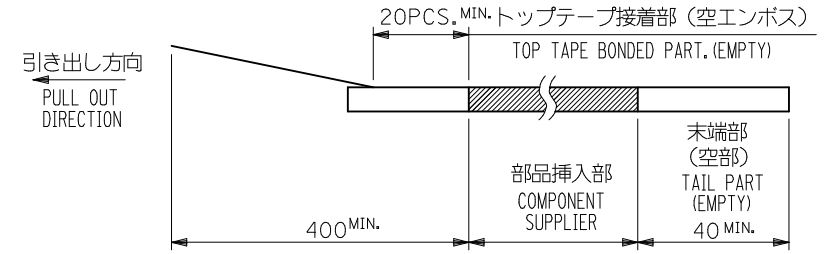

- トップテープの剥離強度：0.1N~1.3N {10gf~130gf}
(剥離方向は下図参照)

尚、本規格値は出荷時に適用。(但し、輸送時に剥離が発生しないこと。)
PEELING OFF FORCE OF TOP TAPE : 0.1N~1.3N {10gf~130gf}
(PEELING DIRECTION AS SHOWN IN FOLLOWING FIG.)
THIS REQUIREMENT SHOULD BE APPLIED AT SHIPMENT.
PEEL OFF SHOULD NOT BE ALLOWED, DURING TRANSPORTATION.

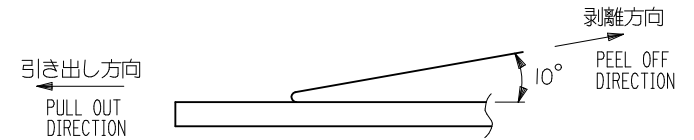

- 材料 (MATERIAL)
キャリアテープ (CARRIER TAPE) : ポリプロピレン (POLYPROPYLENE)
トップテープ (TOP TAPE) : PET, PE, PEF
リール (REEL) : ポリスチレン (PS) <リサイクル材含む>
POLYSTYREN (PS) <RECYCLE MATERIAL CONTAINED>
- C, D 寸法は SHEET 2 ~ 3 を参照下さい。
SEE SHEET 2 ~ 3 (DIMENSION C, D).
- ELV 及び RoHS 適合品。
ELV AND RoHS COMPLIANT.

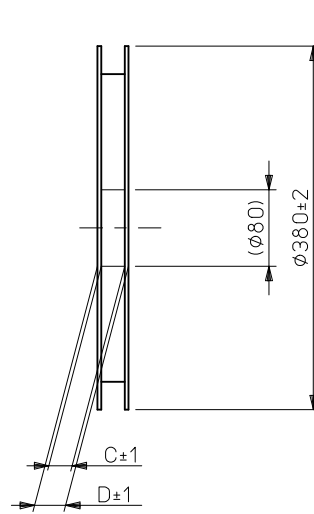
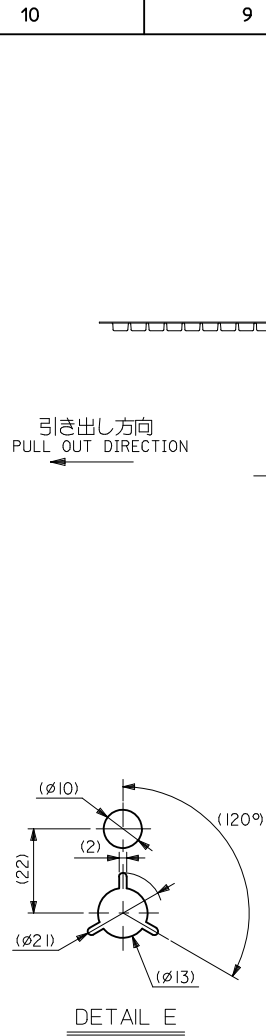

REVISED EC NO: J2010-2187 DRWN: TONO CHKD: HIJIMA APPR: KMORIKAWA REV C	DESCRIPTION 2010/04/30 2010/09/15 2010/10/04	GENERAL TOLERANCES (UNLESS SPECIFIED)		DIMENSION STYLE MM ONLY		SCALE ---	DESIGN UNITS METRIC	THIRD ANGLE PROJECTION		
		10 UNDER	±0.2	DRAWN BY KENSUZUKI	DATE 2004/10/19	TITLE 0.5 FPC CONN NON-ZIF (HGT=1.2MM) EMBSTP PKG				
		10 OVER 30 UNDER	±0.25	CHECKED BY NUKITA	DATE 2004/10/19	MOLEX INCORPORATED				
		30 OVER	±0.3	APPROVED BY NUKITA	DATE 2004/10/19	MATERIAL NO. SEE SHEET 2~4	DOCUMENT NO. SD-51281-012	SHEET NO. 1 OF 4		
ANGULAR ±3 °		DRAFT WHERE APPLICABLE MUST REMAIN WITHIN DIMENSIONS		THIS DRAWING CONTAINS INFORMATION THAT IS PROPRIETARY TO MOLEX INCORPORATED AND SHOULD NOT BE USED WITHOUT WRITTEN PERMISSION						

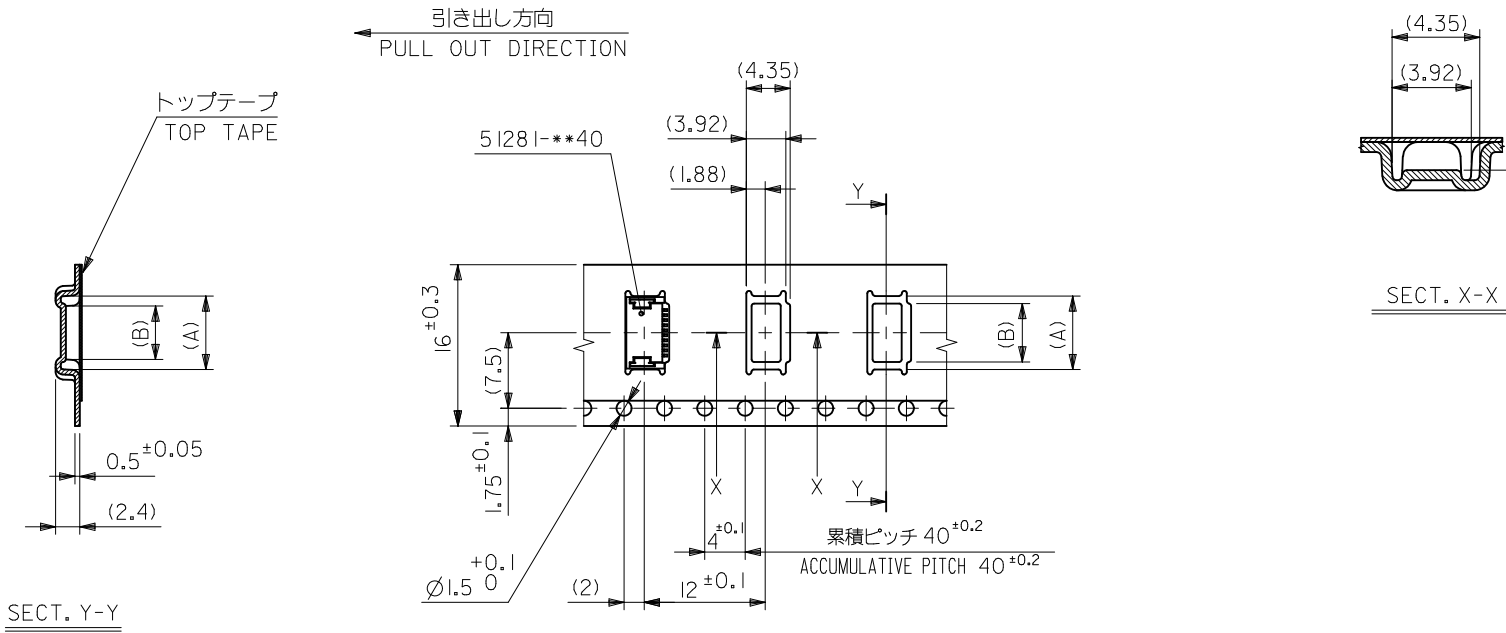

16mm幅キャリアテープ
16mm WIDTH CARRIER TAPE

16	21.4	17.4	4.3	6.3	51281-0894	8
			3.8	5.8	51281-0794	7
			3.3	5.3	51281-0694	6
			2.8	4.8	51281-0594	5
キャリアテープ幅 CARRIER TAPE WIDTH			D	C	(B)	(A)
			製品番号 MATERIAL No.		極数 CIRCUIT	

REVISED EC NO.: J2010-2187 DRWN: TONO 2010/04/30 CHKD: HIJIMA 2010/09/15 APPR: KMORIKAWA 2010/10/04	GENERAL TOLERANCES (UNLESS SPECIFIED)		DIMENSION STYLE MM ONLY		SCALE ---	DESIGN UNITS METRIC	THIRD ANGLE PROJECTION
	10 UNDER	±0.2	DRAWN BY KENSUZUK	DATE 2004/10/19	TITLE 0.5 FPC CONN NON-ZIF (HGT=1.2MM) EMBSTP PKG		
	10 OVER 30 UNDER	±0.25	CHECKED BY NUKITA	DATE 2004/10/19	MOLEX INCORPORATED		
	30 OVER	±0.3	APPROVED BY NUKITA	DATE 2004/10/19	MATERIAL NO. SEE TABLE	DOCUMENT NO. SD-51281-012	SHEET NO. 2 OF 4
	ANGULAR ±3 ° DRAFT WHERE APPLICABLE MUST REMAIN WITHIN DIMENSIONS		THIS DRAWING CONTAINS INFORMATION THAT IS PROPRIETARY TO MOLEX INCORPORATED AND SHOULD NOT BE USED WITHOUT WRITTEN PERMISSION				

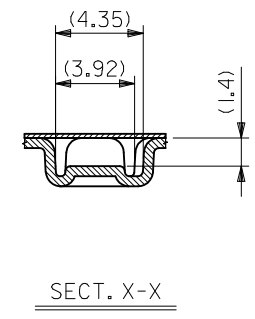
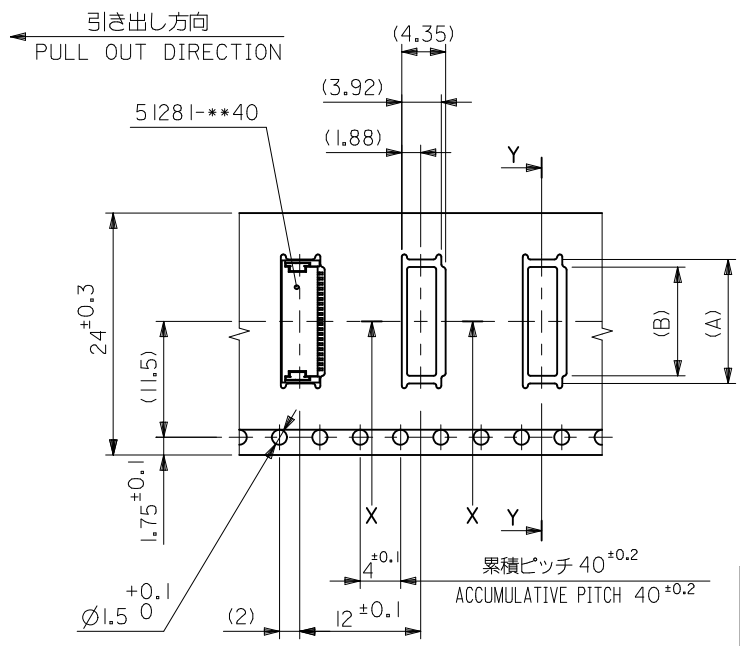
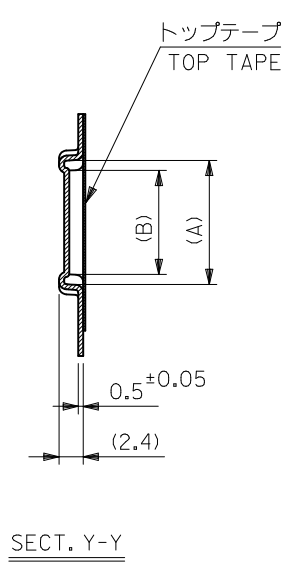

24mm幅キャリアテープ
24mm WIDTH CARRIER TAPE

24	29.4	25.4	12.3	14.3	51281-2494	24		
			11.3	13.3	51281-2294	22		
			10.3	12.3	51281-2094	20		
			9.3	11.3	51281-1894	18		
			8.3	10.3	51281-1694	16		
			7.3	9.3	51281-1494	14		
			6.3	8.3	51281-1294	12		
			5.3	7.3	51281-1094	10		
			4.8	6.8	51281-0994	9		
キャリアテープ幅 CARRIER TAPE WIDTH			D	C	(B)	(A)	製品番号 MATERIAL No.	極数 CIRCUIT

REVISED EC NO.: J2010-2187 DRWN: TONO CHKD: HIJIMA APPR: KMORIKAWA REV C	DESCRIPTION 2010/04/30 2010/09/15 2010/10/04	GENERAL TOLERANCES (UNLESS SPECIFIED)		DIMENSION STYLE MM ONLY		SCALE ---	DESIGN UNITS METRIC	THIRD ANGLE PROJECTION	
		10 UNDER	±0.2	DRAWN BY KENSUZUKI	DATE 2004/10/19	TITLE 0.5 FPC CONN NON-ZIF (HGT=1.2MM) EMBSTP PKG			
		10 OVER 30 UNDER	±0.25	CHECKED BY NUKITA	DATE 2004/10/19	APPROVED BY NUKITA			
		30 OVER	±0.3	MATERIAL NO. SEE TABLE		DOCUMENT NO. SD-51281-012		SHEET NO. 3 OF 4	
ANGULAR ±3 °		DRAFT WHERE APPLICABLE MUST REMAIN WITHIN DIMENSIONS		THIS DRAWING CONTAINS INFORMATION THAT IS PROPRIETARY TO MOLEX INCORPORATED AND SHOULD NOT BE USED WITHOUT WRITTEN PERMISSION					

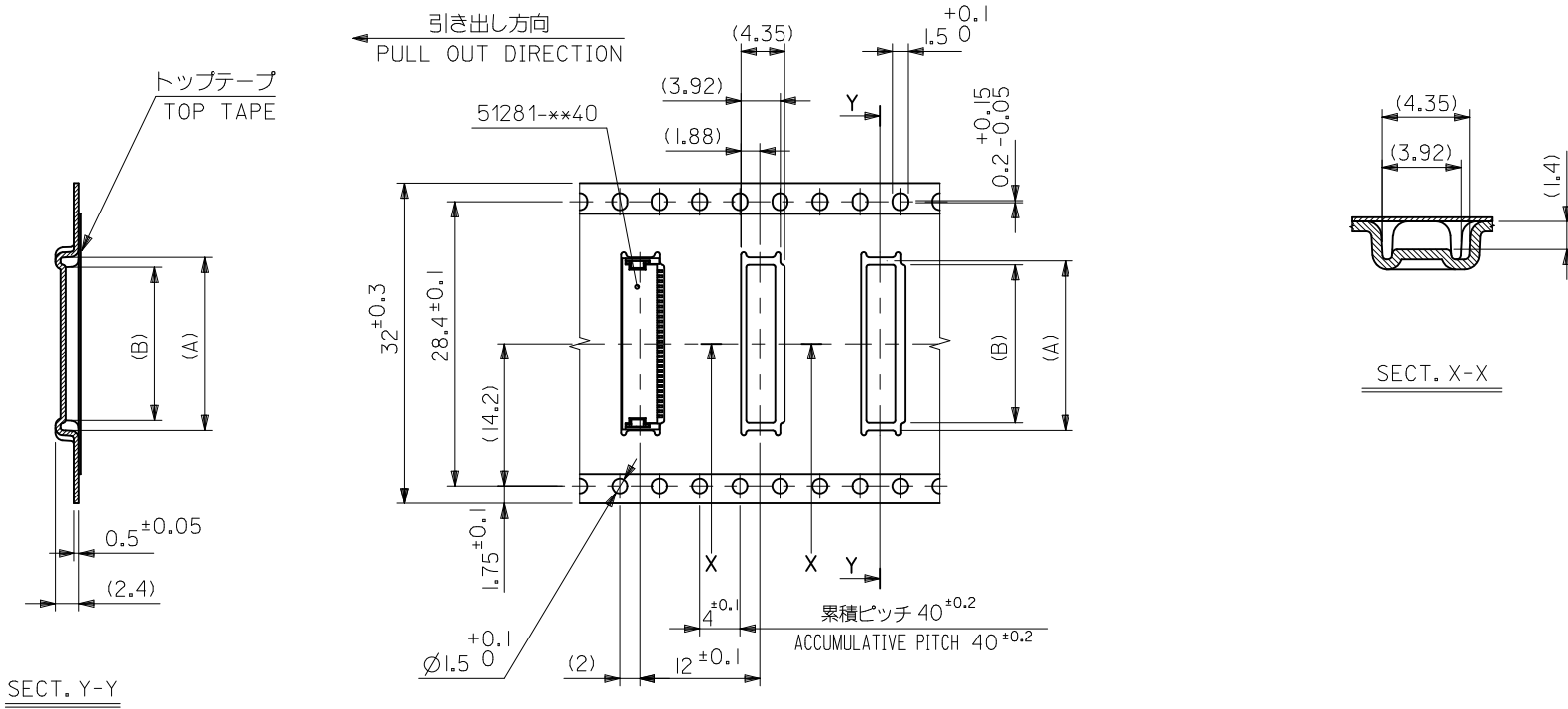

32mm幅キャリアテープ
32mm WIDTH CARRIER TAPE

32	37.4	33.4	13.3	15.3	51281-2694	26
キャリアテープ幅 CARRIER TAPE WIDTH	D	C	(B)	(A)	製品番号 MATERIAL No.	極数 CIRCUIT

REVISED EC NO.: J2010-2187 DRWN: TONO CH'KD: HIJIMA APPR: KMORIKAWA 2010/04/30 2010/09/15 2010/10/04	GENERAL TOLERANCES (UNLESS SPECIFIED)		DIMENSION STYLE MM ONLY		SCALE ---	DESIGN UNITS METRIC	THIRD ANGLE PROJECTION
	10 UNDER	±0.2	DRAWN BY KENSUZUKI	DATE 2004/10/19	TITLE 0.5 FPC CONN NON-ZIF (HGT=1.2MM) EMBSTP PKG		
	10 OVER 30 UNDER	±0.25	CHECKED BY NUKITA	DATE 2004/10/19	APPROVED BY NUKITA 2004/10/19		
	30 OVER	±0.3	MATERIAL NO. SEE TABLE		DOCUMENT NO. SD-51281-012		SHEET NO. 4 OF 4
	ANGULAR ±3 °	THIS DRAWING CONTAINS INFORMATION THAT IS PROPRIETARY TO MOLEX INCORPORATED AND SHOULD NOT BE USED WITHOUT WRITTEN PERMISSION					
	DRAFT WHERE APPLICABLE MUST REMAIN WITHIN DIMENSIONS						