

THIS DRAWING IS UNPUBLISHED. RELEASED FOR PUBLICATION
 © COPYRIGHT - By - ALL RIGHTS RESERVED.

LOC	DIST	REVISIONS			
P	LTR	DESCRIPTION	DATE	DWN	APVD
AF	50	Y3	REVISED PER ECR-20-009164	07AUG2020	MK DH

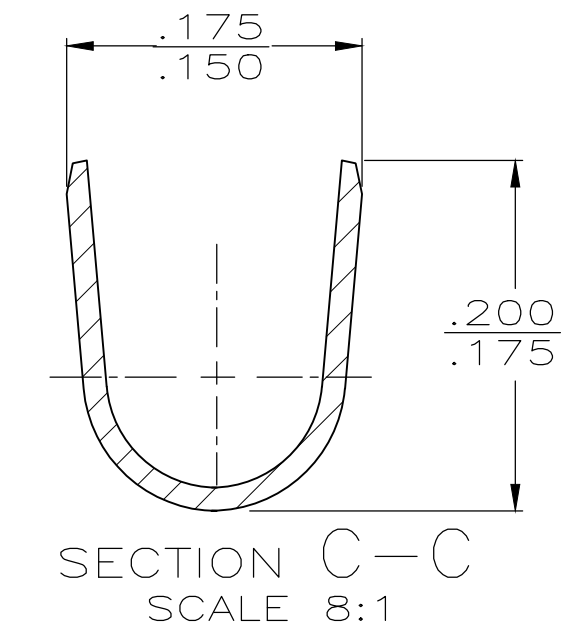
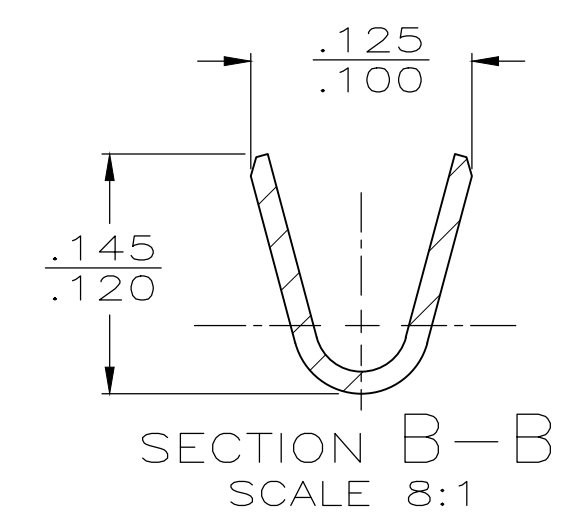
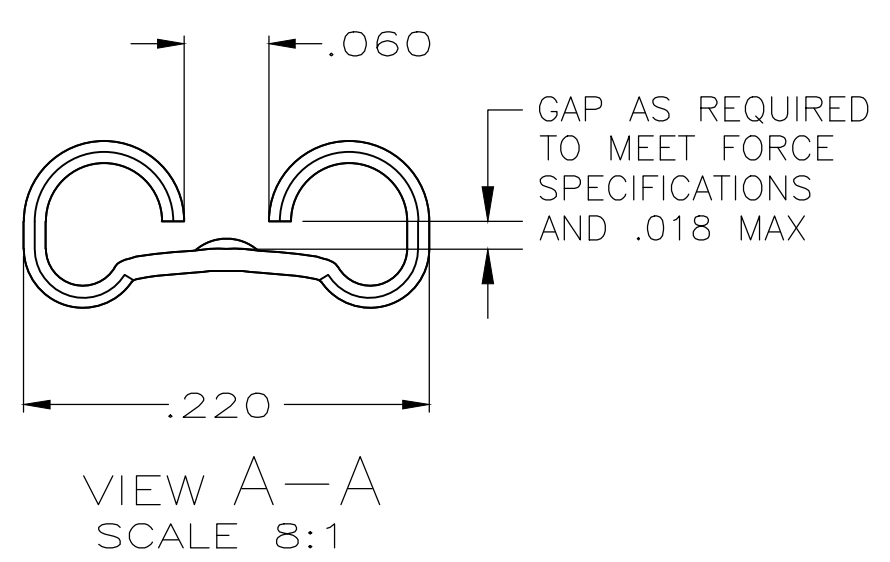
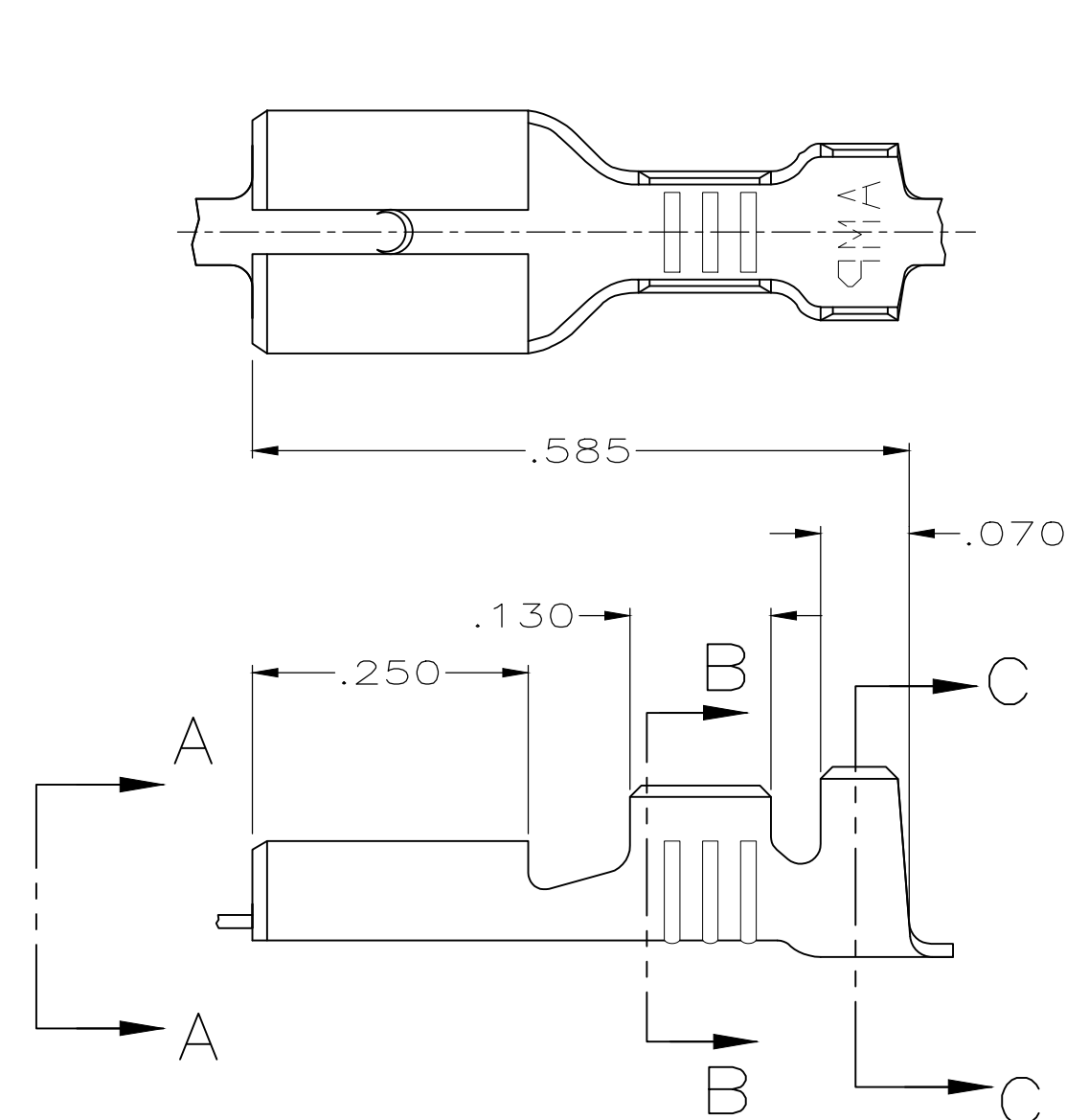

- 1 CONTINUOUS STRIP ON REELS
- 2 MATING TAB THK IS .021-.019
- 3 WIRE SIZE IS #20-#16 AWG
- 4 INSULATION RANGE IS .090-.130 DIA
- △5 60214-3 REFERS TO 60214-1 WITH PAPER INTERLAYER.

-	BRASS	△5 60214-3
TIN	BRASS	60214-2
-	BRASS	60214-1
FINISH	MATERIAL	PART NO.

THIS DRAWING IS A CONTROLLED DOCUMENT.		DWN	JR RUTH	10/27/89	STE TE Connectivity											
DIMENSIONS: INCHES		CHK	MS FEHER	10/27/89												
TOLERANCES UNLESS OTHERWISE SPECIFIED:		APVD	C MEYERS	10/27/89												
<table border="0"> <tr><td>0 PLC</td><td>± -</td></tr> <tr><td>1 PLC</td><td>± -</td></tr> <tr><td>2 PLC</td><td>± -</td></tr> <tr><td>3 PLC</td><td>± .015</td></tr> <tr><td>4 PLC</td><td>± -</td></tr> <tr><td>ANGLES</td><td>± -</td></tr> </table>		0 PLC	± -	1 PLC		± -	2 PLC	± -	3 PLC	± .015	4 PLC	± -	ANGLES	± -	NAME	
0 PLC	± -															
1 PLC	± -															
2 PLC	± -															
3 PLC	± .015															
4 PLC	± -															
ANGLES	± -															
MATERIAL SEE TABLE		FINISH SEE TABLE		PRODUCT SPEC	SIZE	CAGE CODE	DRAWING NO	RESTRICTED TO								
				APPLICATION SPEC	A3	00779	C-60214	-								
				WEIGHT	CUSTOMER DRAWING		SCALE	SHEET	REV							
							6:1	1 OF 1	Y3							