

Product Specification

CWDM Pluggable SFP Transceiver

FWLF15197Dxx

PRODUCT FEATURES

- Up to 1.25 Gb/s bi-directional data links
- Hot-pluggable SFP footprint
- Built-in digital diagnostic functions
- Uncooled DFB laser transmitter in 8 possible CWDM wavelengths
- Duplex LC connector
- Very low jitter
- Metal enclosure, for lower EMI
- Single 3.3V power supply
- Low power dissipation <700mW
- Operating temperature range: 0°C to 70°C



APPLICATIONS

- Metro Access Rings and Point-to-Point networking for Gigabit Ethernet and Fibre Channel

Finisar's FWLF15197Dxx CWDM Small Form Factor Pluggable (SFP) transceivers are designed for operation in Metro Access Rings and Point-to-Point networks using Gigabit Ethernet and Fibre Channel networking equipment. They are available in eight different CWDM wavelengths. Digital diagnostics functions are available via a two wire serial bus. In addition, the transceivers comply with the Small Form Factor Pluggable Multi-Sourcing Agreement (MSA)⁴. The optical transceiver is compliant per the RoHS Directive 2011/65/EU⁵. See Finisar Application Note AN-2038 for more details⁶.

PRODUCT SELECTION

FWLF15197Dxx

xx : (See next page)

Wavelength	xx	Clasp Color Code
1471 nm	47	Gray
1491 nm	49	Violet
1511 nm	51	Blue
1531 nm	53	Green
1551 nm	55	Yellow
1571 nm	57	Orange
1591 nm	59	Red
1611 nm	61	Brown

I. Pin Descriptions

Pin	Symbol	Name/Description	Ref.
1	V _{EET}	Transmitter Ground (Common with Receiver Ground)	1
2	T _{FAULT}	Transmitter Fault. Not supported.	
3	T _{DIS}	Transmitter Disable. Laser output disabled on high or open.	2
4	MOD_DEF(2)	Module Definition 2. Data line for Serial ID.	3
5	MOD_DEF(1)	Module Definition 1. Clock line for Serial ID.	3
6	MOD_DEF(0)	Module Definition 0. Grounded within the module.	3
7	Rate Select	No connection required	4
8	LOS	Loss of Signal indication. Logic 0 indicates normal operation.	5
9	V _{EER}	Receiver Ground (Common with Transmitter Ground)	1
10	V _{EER}	Receiver Ground (Common with Transmitter Ground)	1
11	V _{EER}	Receiver Ground (Common with Transmitter Ground)	1
12	RD-	Receiver Inverted DATA out. AC Coupled	
13	RD+	Receiver Non-inverted DATA out. AC Coupled	
14	V _{EER}	Receiver Ground (Common with Transmitter Ground)	1
15	V _{CCR}	Receiver Power Supply	
16	V _{CCT}	Transmitter Power Supply	
17	V _{EET}	Transmitter Ground (Common with Receiver Ground)	1
18	TD+	Transmitter Non-Inverted DATA in. 100 ohm termination between TD+ and TD-, AC Coupled thereafter.	
19	TD-	Transmitter Inverted DATA in. See TD+	
20	V _{EET}	Transmitter Ground (Common with Receiver Ground)	1

Notes:

- Circuit ground is internally isolated from chassis ground.**
- Laser output disabled on T_{DIS} >2.0V or open, enabled on T_{DIS} <0.8V.
- Should be pulled up with 4.7k – 10kohms on host board to a voltage between 2.0V and 5.5V. MOD_DEF(0) pulls line low to indicate module is plugged in.
- Finisar 2x receiver achieves simultaneous 1x and 2x operation without active control.
- LOS is open collector output. Should be pulled up with 4.7k – 10kohms on host board to a voltage between 2.0V and 5.5V. Logic 0 indicates normal operation; logic 1 indicates loss of signal.

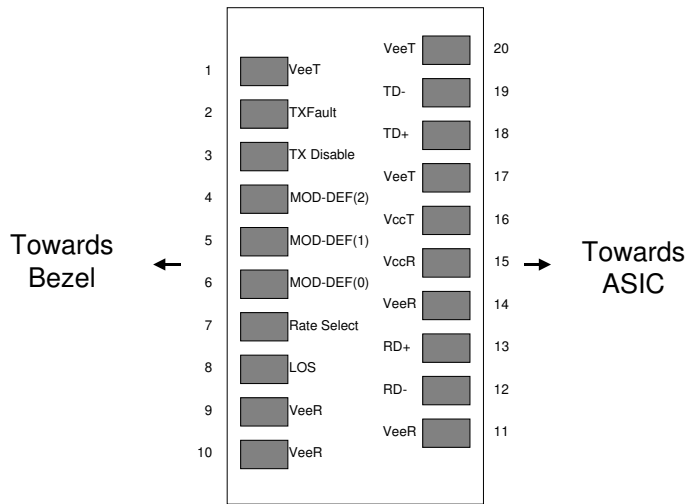

Diagram of Host Board Connector Block Pin Numbers and Names

II. Absolute Maximum Ratings

Parameter	Symbol	Min	Typ	Max	Unit	Ref.
Maximum Supply Voltage	V _{CC}	-0.5		4.7	V	
Storage Temperature	T _S	-40		85	°C	
Case Operating Temperature	T _{OP}	0		70	°C	

III. Electrical Characteristics (T_{OP} = 0 to 70 °C, V_{CC} = 3.15 to 3.60 Volts)

Parameter	Symbol	Min	Typ	Max	Unit	Ref.
Supply Voltage	V _{CC}	3.15		3.60	V	
Supply Current	I _{CC}		200	300	mA	
Transmitter						
Input differential impedance	R _{in}		100		Ω	1
Single ended data input swing	V _{in,pp}	250		1200	mV	
Transmit Disable Voltage	V _D	V _{CC} - 1.3		V _{CC}	V	
Transmit Enable Voltage	V _{EN}	V _{EE}		V _{EE} + 0.8	V	2
Transmit Disable Assert Time				10	us	
Receiver						
Single ended data output swing	V _{out,pp}	250		800	mV	3
Data output rise time	t _r		100	175	ps	4
Data output fall time	t _f		100	175	ps	4
LOS Fault	V _{LOS fault}	V _{CC} - 0.5		V _{CC HOST}	V	5
LOS Normal	V _{LOS norm}	V _{EE}		V _{EE} +0.5	V	5
Power Supply Rejection	PSR	100			mVpp	6

Notes:

1. Connected directly to TX data input pins. AC coupled thereafter.

2. Or open circuit.
3. Into 100 ohms differential termination.
4. 20 – 80 %
5. Loss Of Signal is LVTTTL. Logic 0 indicates normal operation; logic 1 indicates no signal detected.
6. Receiver sensitivity is compliant with power supply sinusoidal modulation of 20 Hz to 1.5 MHz up to specified value applied through the recommended power supply filtering network.

IV. Optical Characteristics ($T_{OP} = 0$ to 70 °C, $V_{CC} = 3.15$ to 3.60 Volts)

Parameter	Symbol	Min	Typ	Max	Unit	Ref.
Transmitter						
Output Opt. Pwr (End of Life)	P_{OUT}	+0		+5	dBm	1
Optical Wavelength	λ	(x-6.5)	(x)	(x+6.5)	nm	2
Wavelength Temperature Dependence			0.08	0.125	nm/°C	
Spectral Width (-20dB)	σ			1	nm	
Optical Extinction Ratio	ER	9			dB	
Sidemode Suppression ratio	SSR_{min}	30			dB	
Optical Rise/Fall Time	t_r/t_f			180	ps	3
RIN	RIN			-120	dB/Hz	
Transmitter Jitter (peak to peak)				100	ps	
Receiver						
Average Rx Sensitivity @ Gigabit Ethernet	R_{SENS3}			-23.0	dBm	4
Maximum Input Power	P_{MAX}	0			dBm	
Optical Center Wavelength	λ_C	1260		1620	nm	
LOS De-Assert	LOS_D			-19	dBm	
LOS Assert	LOS_A	-30			dBm	
LOS Hysteresis			1.0		dB	
Receiver Jitter Generation @ 1.25Gbps				160	ps	5

Notes:

1. Class 1 Laser Safety per FDA/CDRH and IEC-825-1 regulations.
2. Over case temperature of 0 to 70 °C. The Transmitter Center Wavelength “x” is as specified by the customer. The current available wavelengths are: 1471, 1491, 1511, 1531, 1551, 1571, 1591, and 1611 nm. Please see the “Product Selection” section on page 1.
3. Unfiltered
4. With worst-case extinction ratio. Measured with a PRBS 2^7-1 test pattern, @ 1.25Gb/s, BER < 10^{-12} .
5. Jitter added by receiver (peak to peak). Measured at -23dBm average Rx sensitivity, PRBS 2^7-1 test pattern.

V. General Specifications

Parameter	Symbol	Min	Typ	Max	Units	Ref.
Data Rate	BR	0.622		1.25	Gb/sec	
Total System Budget	--	23.0	25.0		dB	@1.25 Gb/s, BER < 10 ⁻¹² w/ PRBS 2 ⁷ -1.

VI. Environmental Specifications

Finisar CWDM SFP transceivers have an operating temperature range from 0°C to +70°C case temperature.

Parameter	Symbol	Min	Typ	Max	Units	Ref.
Case Operating Temperature	T _{op}	0		70	°C	
Storage Temperature	T _{sto}	-40		85	°C	

VII. Regulatory Compliance

Finisar CWDM SFP transceivers are Class 1 Laser Products. They are certified per the following standards:

Feature	Agency	Standard	Certificate Number
Laser Eye Safety	FDA/CDRH	CDRH and IEC-825 Class 1 Laser Product. See Note 1	
Laser Eye Safety	TÜV	EN 60950 EN 60825-1 EN 60825-2	
Electrical Safety	CSA	CLASS 3862.07 CLASS 3862.87	

Note 1: Complies with FDA performance standards for laser products except for deviations pursuant to Laser Notice No. 50, dated July 26, 2001.

VIII. Digital Diagnostic Functions

Finisar FWLF15197Dxx SFP transceivers support the 2-wire serial communication protocol as defined in the draft SFP MSA¹. It is very closely related to the E²PROM defined in the GBIC standard, with the same electrical specifications.

The standard SFP serial ID provides access to identification information that describes the transceiver's capabilities, standard interfaces, manufacturer, and other information.

Additionally, Finisar SFP transceivers provide a unique enhanced digital diagnostic monitoring interface, which allows real-time access to device operating parameters such as transceiver temperature, laser bias current, transmitted optical power, received optical power and transceiver supply voltage. It also defines a sophisticated system of alarm and warning flags, which alerts end-users when particular operating parameters are outside of a factory set normal range.

The SFP MSA defines a 256-byte memory map in E²PROM that is accessible over a 2-wire serial interface at the 8 bit address 1010000X (A0h). The digital diagnostic monitoring interface makes use of the 8 bit address 1010001X (A2h), so the originally defined serial ID memory map remains unchanged. The interface is identical to, and is thus fully backward compatible with both the GBIC Specification and the SFP Multi Source Agreement. The complete interface is described in Finisar Application Note AN-2030: "Digital Diagnostics Monitoring Interface for SFP Optical Transceivers".

IX. Mechanical Specifications

Finisar's Multi-rate CWDM Small Form Factor Pluggable (SFP) transceivers are compatible with the dimensions defined by the SFP Multi-Sourcing Agreement (MSA).

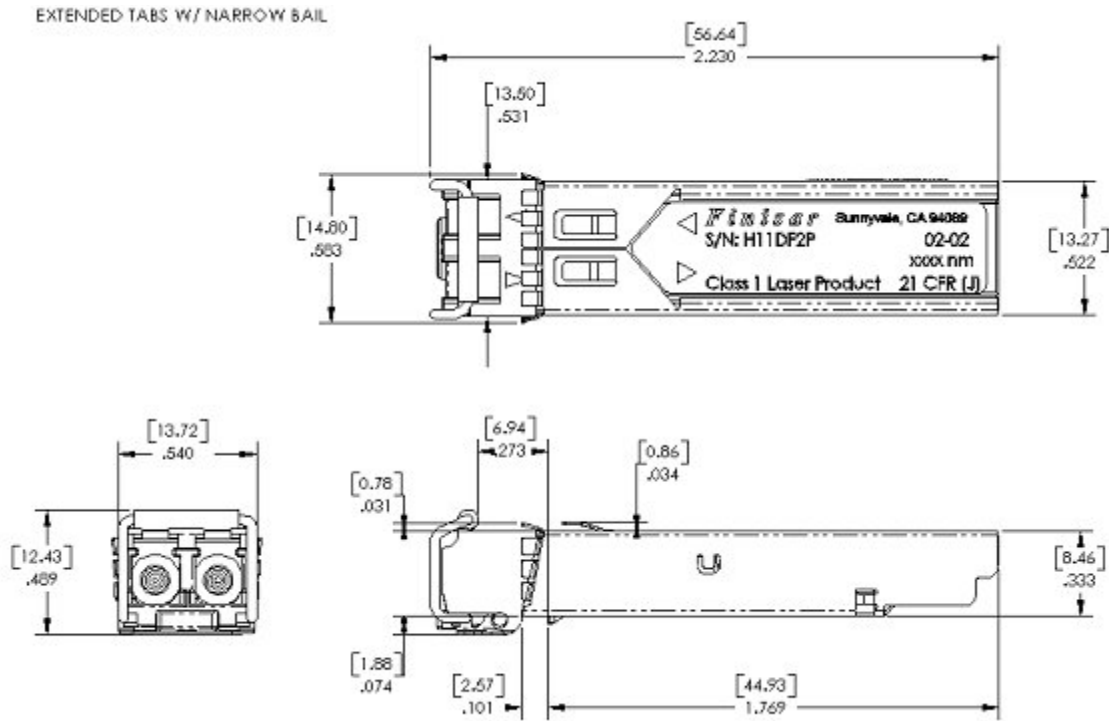

FWLF-1519-7D-xx (dimensions are in inches)

XI. References

1. Small Form Factor Pluggable (SFP) Transceiver Multi-Source Agreement (MSA), September 2000. Documentation is currently available at Finisar upon request.
2. Bellcore GR-253 and ITU-T G.957 Specifications.
3. IEEE Std 802.3. IEEE Standards Department, 2000.^(*)
4. “Fibre Channel Draft Physical Interface Specification (FC-PI 10.0)”. American National Standard for Information Systems.^(*)
5. Directive 2011/65/EU of the European Council Parliament and of the Council, “on the restriction of the use of certain hazardous substances in electrical and electronic equipment”. Certain products may use one or more exemptions as allowed by the Directive.
6. “Application Note AN-2038: Finisar Implementation of RoHS Compliant Transceivers”.

(*) Neither IEEE 802.3 nor FC-PI 10.0 specifies a 15xx nm DFB single mode interface. The FWLF15197Dxx complies with these specifications except for the following optical parameters, which have different values: transmitter wavelength, receiver sensitivity, and transmit output power. See Section IV for details.

XII. For More Information

Finisar Corporation
1308 Moffett Park Drive
Sunnyvale, CA 94089-1133
Tel. 1-408-548-1000
Fax 1-408-541-6138
sales@finisar.com
www.finisar.com