



1087.5 MHz Ceramic Bandpass Filter

Part Number: AM1087B1576

ANATECH ELECTRONICS INC
RF & Microwave Filters & Products



Electrical specifications

- Center Frequency:** 1087.5MHz
- Bandwidth:** 20MHz min
- Insertion loss:** 5.0 dB Max
- Ripple in BW:** 1.0 dB Max
- VSWR in BW:** 1.5:1 Min
- Attenuation:** 20dBc Min@1062.5MHz
20dBc Min@1112.5MHz
60dB Min@1037.5MHz
55dB Min@1137.5MHz
60dB Min@dc~1077.5MHz
50dB Min@1200~3000MHz
- Obsolute Group Delay at center Frequency:** 45 nsec Max
- Group Delay Vibration across Fc±10MHz:** 10 nsec max
- In/Out Impedance:** 50Ω

Mechanical

- Mounting Method:** SMT
- Dimensions:** 1.03" x 0.55" x 0.18" in

Environmental

- Operating Temperature:** -40°C to +85°C
- Storage Temperature:** -55°C to +100°C
- Moisture Resistance:** Leave the product in the test bath at temperatures -40°C ±2°C and humidity 90 to 95% for 48±2hours. Take it out leave it in a stationary state for 1 to 2 hours
- Vibration Resistance:** Test the product by vibration of full amplitude 1.5 mm at 5Hz ~ 55Hz and acceleration 49m/s² at 55 ~ 150 Hz by sweep 0.1 oct/min. for 2 hours each in the direction of x, y, z

This product is RoHs compliant.

Outline Drawing:

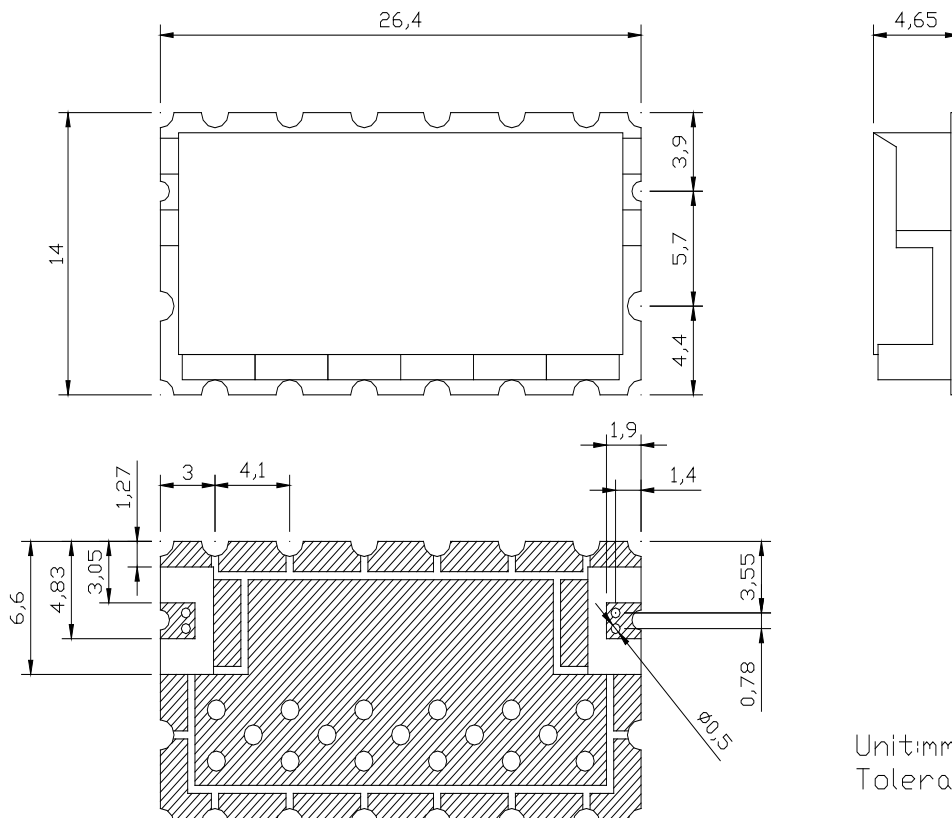

Unit:mm
Tolerance:±0.3