

NCS2561, NCV2561

Video Amplifier, 1-Channel, With Reconstruction Filter and SAG Correction

The NCS2561 is a single high speed video driver including a 2-pole reconstruction filter and SAG correction capability. The NCS2561 is available in a space saving SC-88 package optimized for low voltage, portable applications. It is designed to be compatible with Digital-to-Analog Converters (DAC) embedded in most video processors.

The NCS2561 internally integrates an 8 MHz 2-pole video DAC reconstruction filter with a fixed gain of 2. The NCS2561 also has a built-in SAG correction circuit when used at the output in an AC-coupled mode. To further reduce power consumption, an enable pin is provided.

Features

- Internal 8 MHz 2-Pole Reconstruction Filter
- Internal Fixed Gain: 6 dB
- Integrated Level Shifter
- SAG Correction Circuit for Reducing Coupling Capacitor Size
- Low Quiescent Current: 6 mA Typ
- Shutdown Current < 5 μ A
- Wide Input Voltage Range
- Capability to Drive 2 CVBS Video Signals Together (2x150 Ω Loads)
- Excellent Video Performance
- Operating Supply Voltage Range: +2.7 V to +3.3 V
- NCV Prefix for Automotive and Other Applications Requiring Unique Site and Control Change Requirements; AEC-Q100 Qualified and PPAP Capable
- These Devices are Pb-Free and are RoHS Compliant

Applications

- Portable Video, Digital Cameras & Camera Phones
- Set-Top Box Video Filters
- NTSC and PAL

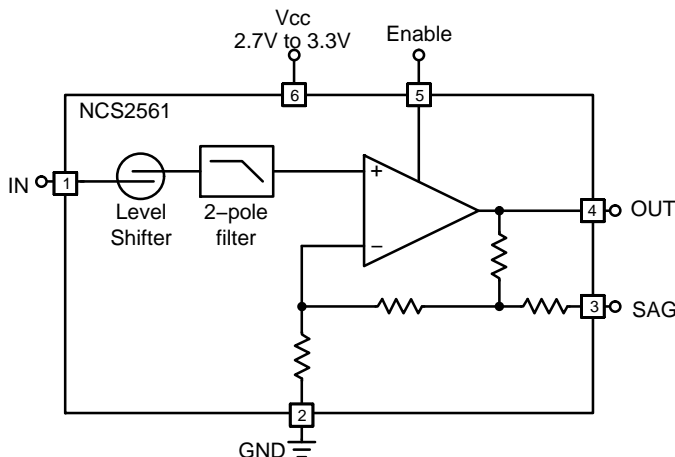

Figure 1. Block Diagram



ON Semiconductor®

www.onsemi.com



SC-88
SQ SUFFIX
CASE 419B

MARKING DIAGRAMS

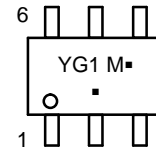

YG1 = Specific Device Code

M = Date Code*

• = Pb-Free Package

(Note: Microdot may be in either location)

*Date Code orientation and/or position may vary depending upon manufacturing location.

PIN CONNECTIONS

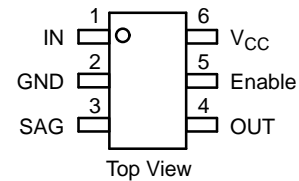

ORDERING INFORMATION

Device	Package	Shipping†
NCS2561SQT1G	SC-88 (Pb-Free)	3000 / Tape & Reel
NCV2561SQT1G	SC-88 (Pb-Free)	3000 / Tape & Reel

†For information on tape and reel specifications, including part orientation and tape sizes, please refer to our Tape and Reel Packaging Specifications Brochure, BRD8011/D.

Related Resource:

Refer to Application Note AND8457/D for details regarding SAG Correction

NCS2561, NCV2561

PIN FUNCTION AND DESCRIPTION

Pin	Name	Type	Description
1	IN	Input	Video Input
2	GND	Ground	Ground
3	SAG	Output	Sag Compensation
4	OUT	Output	Video Output
5	Enable	Input	Enable / Disable Function: High = Enable, Low = Disable. When left open the default state is High.
6	V _{CC}	Power	Power Supply / $2.7\text{ V} \leq V_{CC} \leq 3.3\text{ V}$

ATTRIBUTES

Characteristic	Value
ESD Protection (Note 1)	Human Body Model Machine Model
Latch-up Current (Note 2)	75 mA
Moisture Sensitivity (Note 3)	Level 1
Flammability Rating	Oxygen Index: 28 to 34 UL 94 V-0 @ 0.125 in

- This device series incorporates ESD protection and is tested by the following methods:
ESD Human Body Model tested per JEDEC standard JS-001-2017 (AEC-Q100-002)
ESD Charged Device Model tested per JEDEC standard JS-002-2014 (AEC-Q100-011).
- Latch-up Current tested per JEDEC standard JESD78E (AEC-Q100-004).
- For additional Moisture Sensitivity information, refer to Application Note AND8003/D.

MAXIMUM RATINGS

Rating	Symbol	Value	Unit
Power Supply Voltages	V _{CC}	3.6	Vdc
Input Voltage Range	V _I	-0.5 to V _{CC} + 0.5	Vdc
Output Short-Circuit to GND thru 75 Ω	I _{SC}	Continuous	-
Maximum Junction Temperature (Note 4)	T _J	150	°C
Operating Ambient Temperature	T _A	-40 to +125 -40 to +125	°C
Storage Temperature Range	T _{stg}	-60 to +150	°C
Thermal Resistance, Junction-to-Air	R _{θJA}	250	°C/W

Stresses exceeding those listed in the Maximum Ratings table may damage the device. If any of these limits are exceeded, device functionality should not be assumed, damage may occur and reliability may be affected.

- Power dissipation must be considered to ensure maximum junction temperature (T_J) is not exceeded.
- NCV prefix is for automotive and other applications requiring site and change control.

MAXIMUM POWER DISSIPATION

The maximum power that can be safely dissipated is limited by the associated rise in junction temperature. For the plastic packages, the maximum safe junction temperature is 150°C. If the maximum is exceeded momentarily, proper circuit operation will be restored as

soon as the die temperature is reduced. Leaving the device in the “overheated” condition for an extended period can result in device burnout. To ensure proper operation, it is important to observe the de-rating curves.

NCS2561, NCV2561

DC ELECTRICAL CHARACTERISTICS with $V_{CC} = 2.7\text{ V to }3.3\text{ V}$ ($T_A = +25^\circ\text{C}$, $R_L = 150\ \Omega$ to GND, unless otherwise specified)

Symbol	Characteristic	Conditions	Min	Typ	Max	Unit
DC PERFORMANCE						
V_{OLS}	Offset Level–Shift Output Voltage $T_A = -40^\circ\text{C to }+125^\circ\text{C}$ (Note 6)	$V_{CC} = 3.3\text{ V}$, $V_{IN} = 0\text{ V}$	10	60 60	80	mV
I_{IB}	Input Bias Current			± 3		pA
V_{IN}	Input Voltage Range (Note 7)	$V_{CC} = 3.3\text{ V}$	GND		$V_{CC} - 1.5$	V
A_V	Voltage Gain	$V_{CC} = 3.3\text{ V}$, $0 < V_{IN} < 1.5\text{ V}$ 40 IRE Sync, 100 IRE White Level	5.8	6.0	6.2	dB
V_{IH}	Enable Input High Level Voltage		1.6		V_{CC}	V
V_{IL}	Enable Input Low Level Voltage		GND		0.8	V

OUTPUT CHARACTERISTICS

V_{OH}	Output High Level Voltage	$R_L = 150\ \Omega$ to GND $R_L = 75\ \Omega$ to GND	$V_{CC} - 0.3$	$V_{CC} - 0.1$ $V_{CC} - 0.3$		V
V_{OL}	Output Low Level Voltage (Note 8)			60		mV
I_O	Output Current	$V_{CC} = 3.3\text{ V}$		± 50		mA

POWER SUPPLY

V_{CC}	Operating Voltage Range		2.7		3.3	V
$I_{CC, ON}$	Power Supply Current – Enabled $T_A = -40^\circ\text{C to }+125^\circ\text{C}$ (Note 6)	$V_{IN} = 0\text{ V}$, $V_{CC} = 3.3\text{ V}$, $I_O = 0\text{ mA}$		6.0	7.5 9.0	mA
$I_{CC, OFF}$	Power Supply Current – Disabled	$V_{IN} = 0\text{ V}$, $V_{CC} = 3.3\text{ V}$, $I_O = 0\text{ mA}$		1.5	5.0	μA
PSRR	Power Supply Rejection Ratio	$V_{CC} = 2.7\text{ V to }3.3\text{ V}$		± 80		$\mu\text{V/V}$

6. Guaranteed by design and/or characterization.
 7. Limited by output swing and internal gain.
 8. Output low voltage level is limited by the internal level shift circuitry.

AC ELECTRICAL CHARACTERISTICS with $V_{CC} = 2.7\text{ V to }3.3\text{ V}$ ($T_A = +25^\circ\text{C}$, $R_L = 150\ \Omega$ to GND, unless otherwise specified)

Symbol	Characteristic	Conditions	Min	Typ	Max	Unit
FREQUENCY DOMAIN PERFORMANCE						
A_n	Normalized Passband Gain (Note 9)	$V_{CC}=3.3\text{ V}$, $f=1.0\text{ MHz}$, $V_O=2\text{ V}_{p-p}$ $V_{CC}=3.3\text{ V}$, $f=4.5\text{ MHz}$, $V_O=2\text{ V}_{p-p}$ $f = 27\text{ MHz}$, $V_O = 2\text{ V}_{p-p}$	-0.4 -0.2 -18	0 +0.4 -22	+0.4 +0.8	dB
dG	Differential Gain	$V_{CC} = 3.3\text{ V}$, $A_V = +2$, $R_L = 150\ \Omega$, $f = 3.58\text{ MHz}$, 4.43 MHz		0.5		%
dP	Differential Phase	$V_{CC} = 3.3\text{ V}$, $A_V = +2$, $R_L = 150\ \Omega$, $f = 3.58\text{ MHz}$, 4.43 MHz		1.0		$^\circ$
SNR	Signal to Noise Ratio	$V_{CC} = 3.3\text{ V}$, 100% White Signal		70		dB

TIME DOMAIN RESPONSE

ΔT_g	Group Delay Variation	$V_{CC} = 3.3\text{ V}$, 100 kHz to 5.0 MHz		15		ns
t_{ON}	Turn ON Time			1.5		μs
t_{OFF}	Turn OFF Time			50		ns

9. The normalized gain is guaranteed by design and characterization. The max normalized gain of +0.8 dB is the result of smooth peaking (pre-emphasis, see figure 2) taking into account the increase of the losses at the highest frequencies into connectors and cable at the output. For frequencies lower than 2 MHz the max normalized gain is 0.4 dB.

NCS2561, NCV2561

TYPICAL CHARACTERISTICS (At $T_A = +25^\circ\text{C}$ and $R_L = 150 \Omega$, unless otherwise specified)

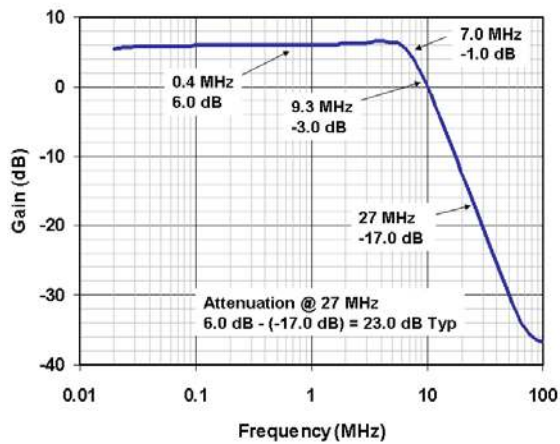

Figure 2. Frequency Response

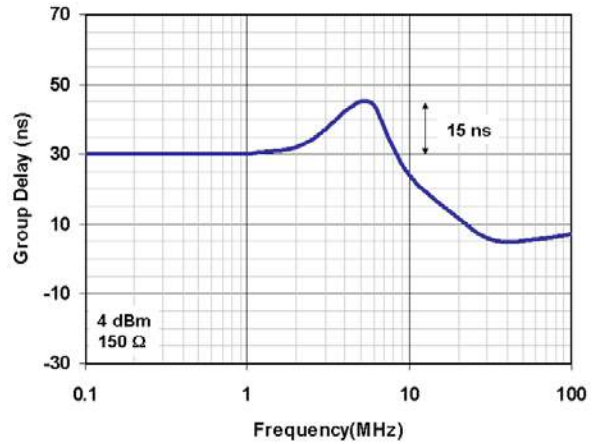

Figure 3. Group Delay vs. Frequency

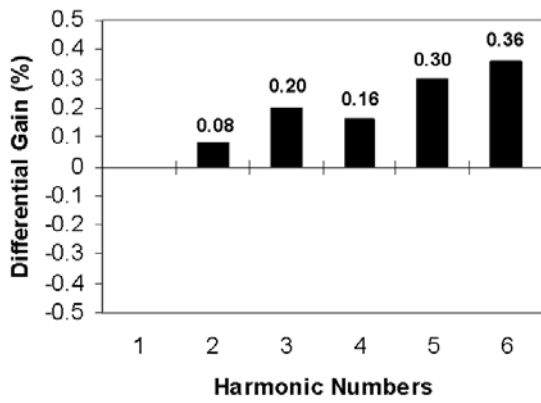

Figure 4. Differential Gain

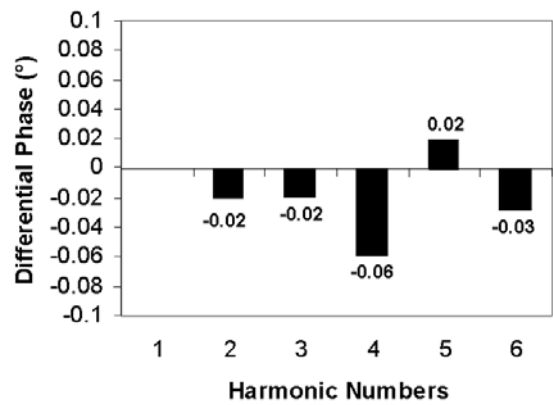

Figure 5. Differential Phase

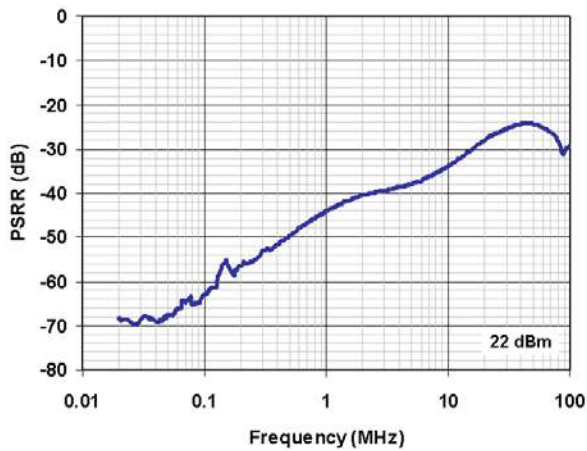

Figure 6. PSRR vs. Frequency

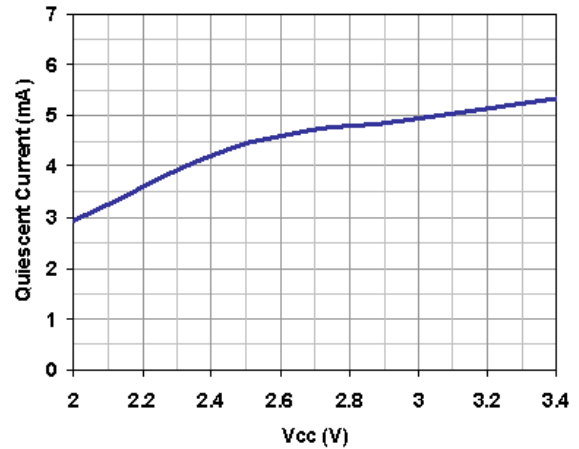

Figure 7. Quiescent Current vs. Supply Voltage

NCS2561, NCV2561

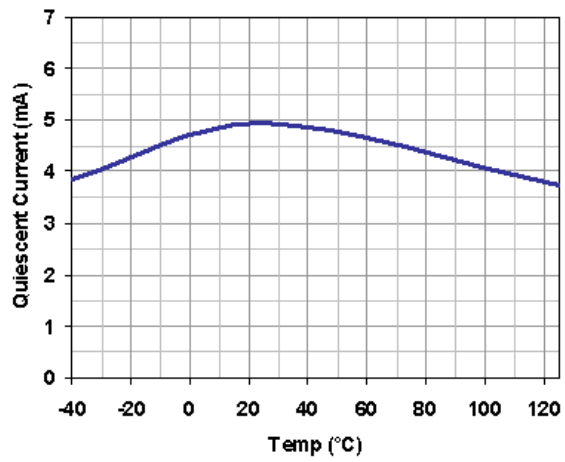

Figure 8. Quiescent Current vs. Temperature
($V_{CC} = 3.0\text{ V}$)

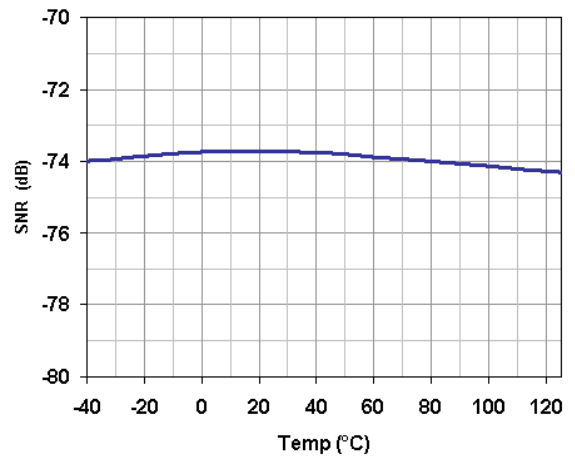

Figure 9. Signal-to-Noise Ratio vs. Temperature

APPLICATIONS INFORMATION

The NCS2561 is a single video driver optimized for portable applications with low power consumption in a space saving SC-88 package. It includes sag correction circuitry allowing significant reduction of the AC-coupled output capacitor.

Internal Level Shift

The input common mode voltage range (see specifications V_{IN}) of the NCS2561 includes the lower rail (GND) and extends to $V_{CC} - 1.5V$ on a power supply range of 2.7 V to 3.3 V. Many video processors operate with a supply ranging from 0 V to a positive supply (typically 3.3 V), so the lowest voltage of the video signal provided by the DAC is 0 V. Although a 0 V (GND) signal is within the input common-mode range of the NCS2561, the output signal will be limited, specifically at the lower rail. Op amps use transistors with saturation voltage (V_{sat}) higher than 0 V. If the lowest level of the input voltage is lower than V_{sat} the signal will be clipped at the output.

To ensure the output signal is not clipped due to the lower rail limit, the NCS2561 has built-in level shift circuitry. The role of this circuitry is to avoid clipping of the sync signal at the output by shifting up the video signal by about 60 mV. The level shift circuitry level shifts the sync signal above the internal op amp transistor saturation limit. This function is particularly useful when the video signal is DC-coupled at the output.

Built-in 2-Pole Reconstruction Filter

The NCS2561 has a 2-pole reconstruction filter with a -3 dB cut-off frequency at 8 MHz. The filter serves as an anti-alias filter removing the unwanted over-sampling effects produced by the video DAC. The 27 MHz over-sampling frequency from the video DAC is attenuated by 22 dB typical. In order to improve the stop-band attenuation a small capacitor (C_s) of a few tenths pico Farads can be added in parallel with the source resistor (R_s) (See Figure 10).

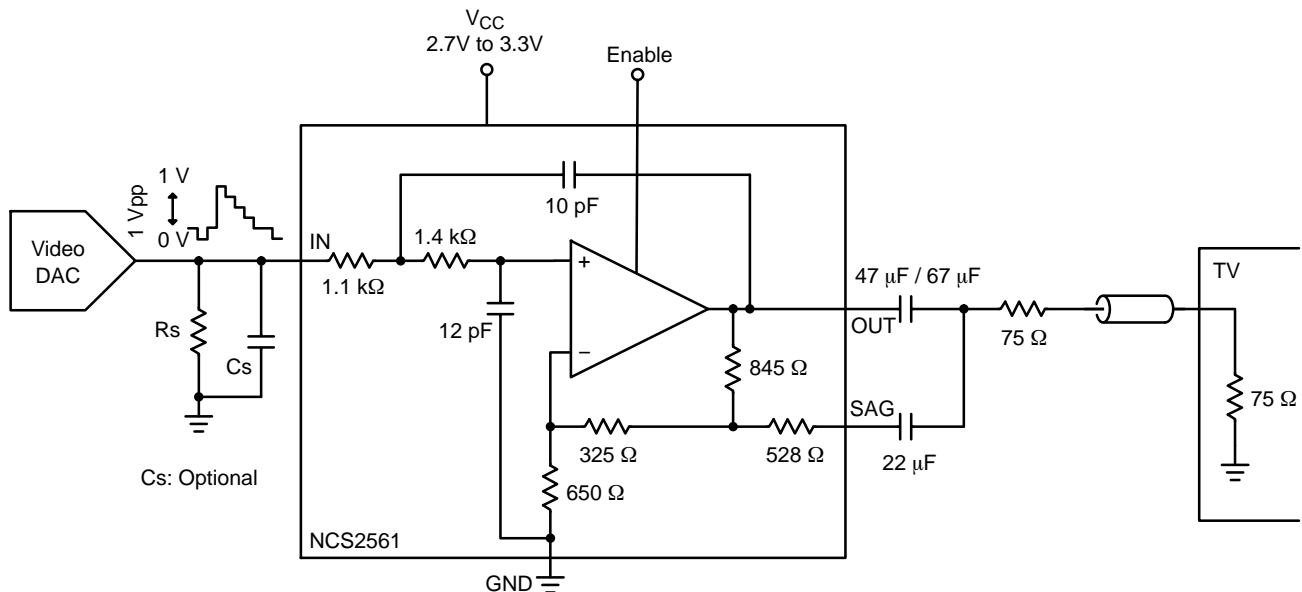

Figure 10. Block Diagram Showing Filter and Sag Correction Circuits

Shutdown Mode

If the Enable pin is left open by default the circuit will be enabled. The Enable pin offers a shutdown function, so the NCS2561 can consequently be disabled when not used. This is particularly important for digital still cameras or cell phones with camera having a video output feature. Indeed

this video output is not permanently used and actually used in very specific period of time when pictures or small movies want to be displayed on a bigger screen. The device's quiescent current drops typically down to 2.7 μA when the device is in the shutdown mode.

Sag Correction

Video drivers that do not incorporate sag compensation traditionally recommend a large coupling capacitor (220 μ F) on the output of the video driver. Larger output coupling capacitors ($\geq 470 \mu$ F) are often chosen by design engineers when the application allows this (Set-Top Box). A larger output coupling capacitor allows a lower cut-off frequency to avoid field tilt effects; however in portable applications there is a trade-off between large and expensive coupling

capacitors, and a coupling configuration to saving space. The sag compensation circuitry allows the reduction of this output coupling capacitor value by inducing peaking at the lower cutoff frequency of the high pass filter. The high-pass filter is created by the coupling capacitor and the load resistor ($1/(2\pi R_L C_{out})$), and this peaking lowers the cutoff frequency. Simulation results provided in Figure 11 show the effect of the sag compensation at the low cut-off frequency.

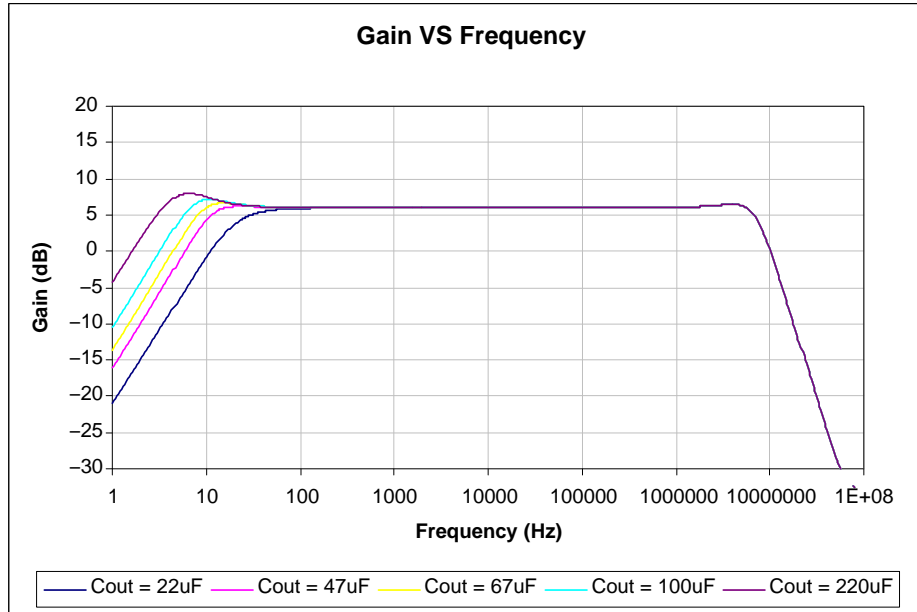

Figure 11. Simulation Results with Csag = 22 μ F and Variable Cout

Calculations show that a 220 μ F output capacitor produces a low cutoff frequency of 5 Hz, and a 470 μ F capacitor will give a low cutoff frequency at 2.6 Hz. The cutoff frequency (-3 dB) is defined by the equation: $1/(2\pi R_L C_{out})$. In the case where no sag is used (Figure 14), a low Cout value can adversely affect the low cutoff

frequency; the cut-off frequency will be in the critical 50 Hz or 60 Hz frequencies. This undesirable affect will manifest itself as field tilt. Due to the SAG correction the large output capacitor is reduced without degrading the video performances by the use of two smaller and cheaper output capacitors.

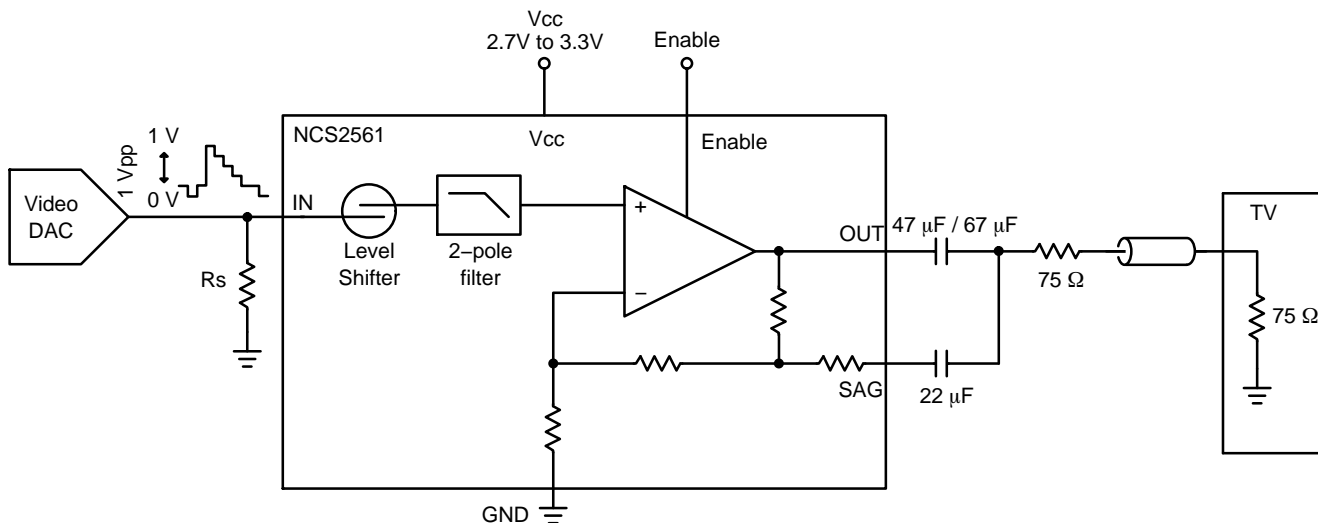

Figure 12. Sag Correction Configuration

NCS2561, NCV2561

The Csag value has no significant impact on the coupling even as the value increases. A value of 22 μF is recommended for optimal performance.

To achieve similar behavior to an output coupling capacitor value $C_{out} = 220 \mu\text{F}$ (no sag) the nominal equivalent sag combination is $C_{sag} = 22 \mu\text{F}$ and $C_{out} = 67 \mu\text{F}$. A value of 47 μF for C_{out} will yield equivalent results. If we consider a coupling cap of 470 μF , the best compromise for sag combination is $C_{sag} = 22 \mu\text{F}$ and $C_{out} = 100 \mu\text{F}$. A value of 67 μF for C_{out} will yield equivalent results.

Figures 13 and 14 show the impact of the output coupling capacitor on a video signal corresponding to a worst case situation regarding the low frequency bandwidth. The video signal used is a 50 Hz 1/2 black – 1/2 white video pattern. This signal is obtained using the PAL Flat Field Square wave signal option available with the video generator TG700 from Tektronix. These measurements show how the sag function can help to reduce the field tilt problem using lower value coupling capacitor than traditional approach.

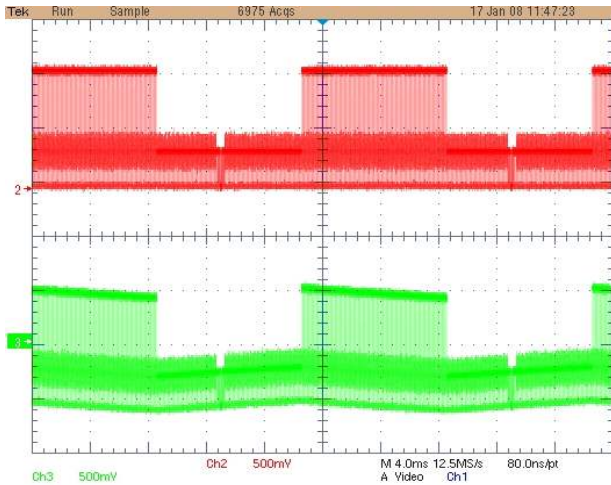

Figure 13. No sag, $C_{out} = 220 \mu\text{F}$
(Top : Input, Bottom : Output)

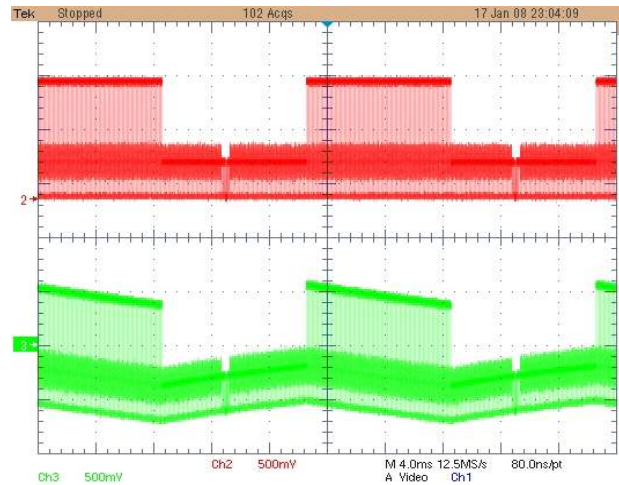

Figure 14. $C_{sag} = 22 \mu\text{F}$, $C_{out} = 47 \mu\text{F}$
(Top : Input, Bottom : Output)

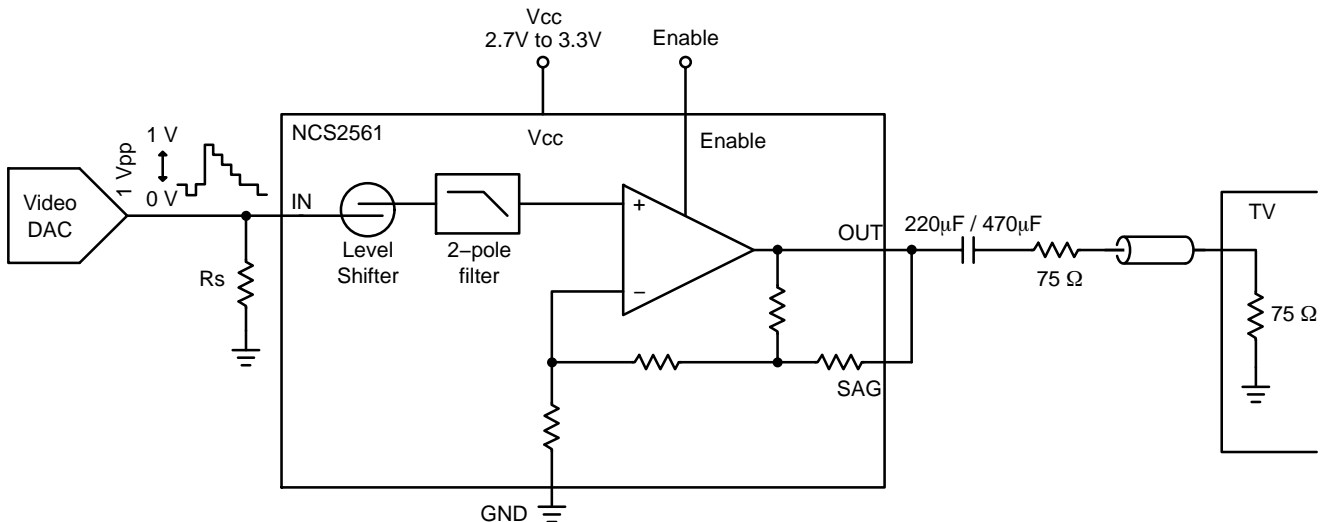

Figure 15. NCS2561 in an AC-Coupled Configuration with no sag

NCS2561, NCV2561

DC-Coupled Output

Having efficient output AC-coupled capability thanks to the sag correction option, with the built-in level shifter, the NCS2561 can also be DC-coupled to a 150 Ω load. This has the advantage of eliminating the AC-coupling capacitors at the output by reducing the number of external components and saving space on the board. This can be a key advantage for some portable applications with limited space.

The problems of field tilt effects on the video signal are also eliminated providing the best video quality with optimal dynamic or peak-to-peak amplitude of the video signal allowing operating at the lower power supply voltage (2.7 V) without risk of signal clipping. In this coupling configuration the average output voltage is higher than 0 V and the power consumption can be a little higher than with an AC-coupled configuration.

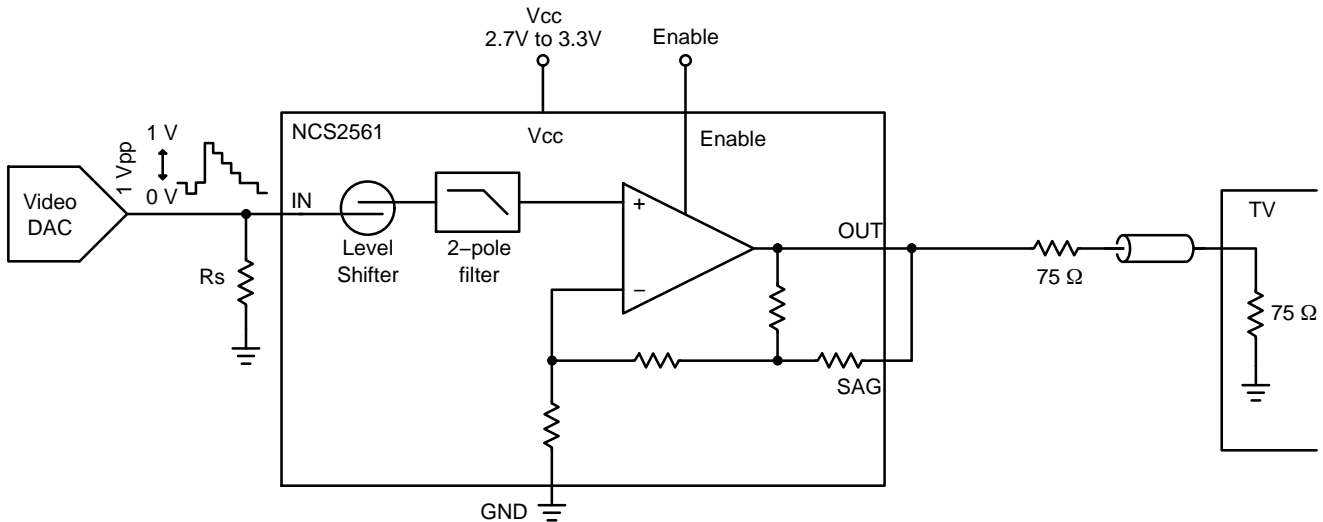

Figure 16. DC-Coupled Input and Output Configuration

Video Driving Capability

With an output current capability of ± 50 mA the NCS2561 was designed to be able to drive at least 2 video display loads in parallel (2 different display or 1 display + 1 VCR). This

applications is illustrated in the Figure 17. Figure 18 (multiburst) and Figure 19 (linearity) show that the video signal can efficiently drive a 75 Ω equivalent load and not degrade the video performance.

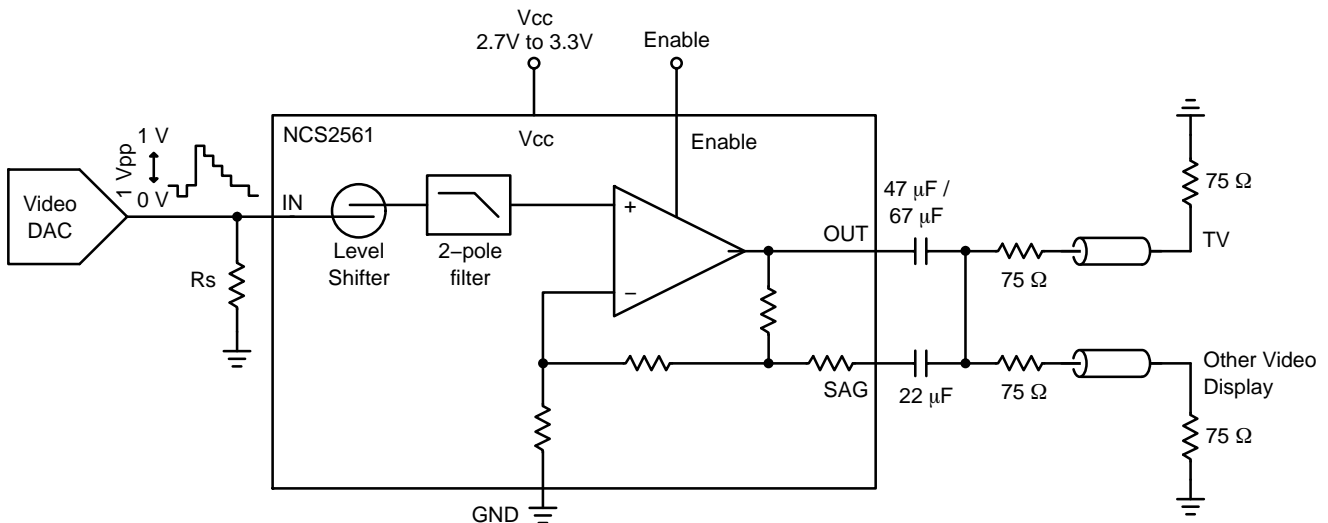

Figure 17. NCS2561 Driving 2 Video Display (two 150 Ω loads)

NCS2561, NCV2561

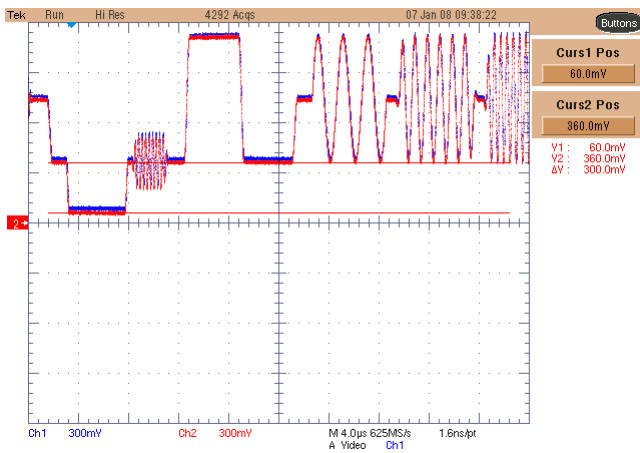

Figure 18. Multiburst Test with two 150 Ω loads

ESD Protection

All the device pins are protected against electrostatic discharge at a level of 2 kV HBM. The output has been considered with a particular attention with ESD structure able to sustain typically more than 2 kV HBM. Actually

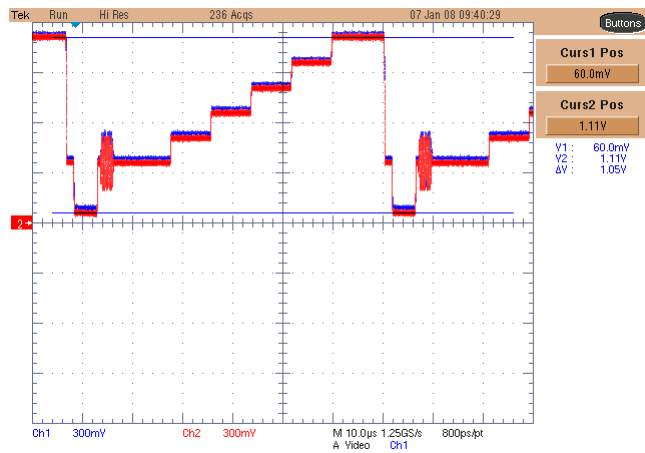

Figure 19. Linearity Test with two 150 Ω loads

more than 4 kV has been measured on this specific output pin. This feature is particularly important for video driver which usually constitutes the last stage in the video chain before the video output connector.

MECHANICAL CASE OUTLINE PACKAGE DIMENSIONS



1
SCALE 2:1

SC-88/SC70-6/SOT-363
CASE 419B-02
ISSUE Y

DATE 11 DEC 2012

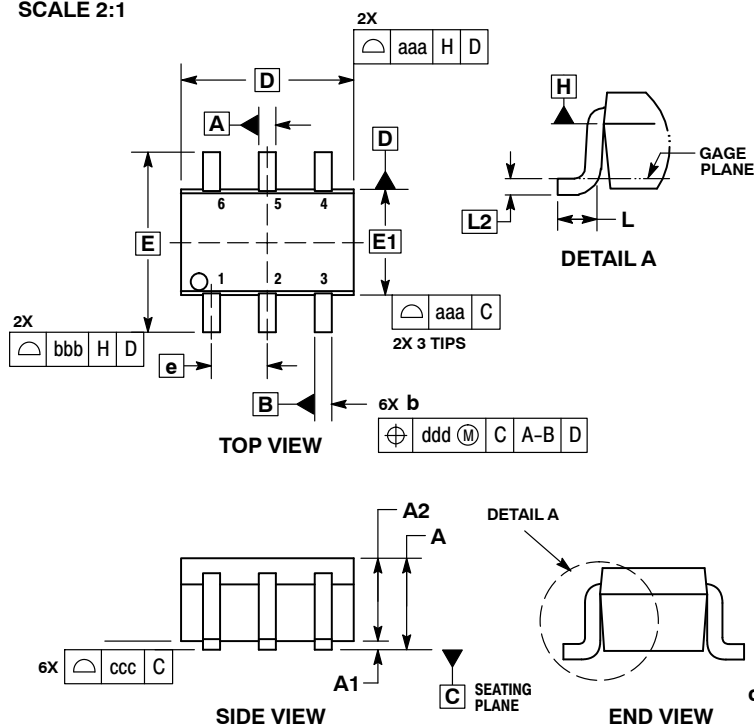

- NOTES:
1. DIMENSIONING AND TOLERANCING PER ASME Y14.5M, 1994.
 2. CONTROLLING DIMENSION: MILLIMETERS.
 3. DIMENSIONS D AND E1 DO NOT INCLUDE MOLD FLASH, PROTRUSIONS, OR GATE BURRS. MOLD FLASH, PROTRUSIONS, OR GATE BURRS SHALL NOT EXCEED 0.20 PER END.
 4. DIMENSIONS D AND E1 AT THE OUTERMOST EXTREMES OF THE PLASTIC BODY AND DATUM H.
 5. DATUMS A AND B ARE DETERMINED AT DATUM H.
 6. DIMENSIONS b AND c APPLY TO THE FLAT SECTION OF THE LEAD BETWEEN 0.08 AND 0.15 FROM THE TIP.
 7. DIMENSION b DOES NOT INCLUDE DAMBAR PROTRUSION. ALLOWABLE DAMBAR PROTRUSION SHALL BE 0.08 TOTAL IN EXCESS OF DIMENSION b AT MAXIMUM MATERIAL CONDITION. THE DAMBAR CANNOT BE LOCATED ON THE LOWER RADIUS OF THE FOOT.

DIM	MILLIMETERS			INCHES		
	MIN	NOM	MAX	MIN	NOM	MAX
A	---	---	1.10	---	---	0.043
A1	0.00	---	0.10	0.000	---	0.004
A2	0.70	0.90	1.00	0.027	0.035	0.039
b	0.15	0.20	0.25	0.006	0.008	0.010
C	0.08	0.15	0.22	0.003	0.006	0.009
D	1.80	2.00	2.20	0.070	0.078	0.086
E	2.00	2.10	2.20	0.078	0.082	0.086
E1	1.15	1.25	1.35	0.045	0.049	0.053
e	0.65 BSC			0.026 BSC		
L	0.26	0.36	0.46	0.010	0.014	0.018
L2	0.15 BSC			0.006 BSC		
aaa	0.15			0.006		
bbb	0.30			0.012		
ccc	0.10			0.004		
ddd	0.10			0.004		

GENERIC MARKING DIAGRAM*

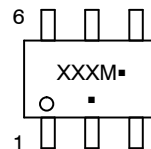

- XXX = Specific Device Code
- M = Date Code*
- = Pb-Free Package

(Note: Microdot may be in either location)

*Date Code orientation and/or position may vary depending upon manufacturing location.

*This information is generic. Please refer to device data sheet for actual part marking. Pb-Free indicator, "G" or microdot "▪", may or may not be present. Some products may not follow the Generic Marking.

RECOMMENDED SOLDERING FOOTPRINT*

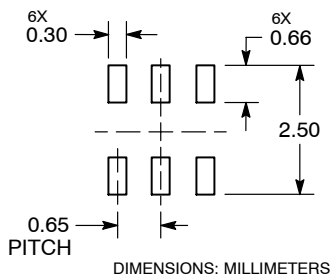

*For additional information on our Pb-Free strategy and soldering details, please download the ON Semiconductor Soldering and Mounting Techniques Reference Manual, SOLDERRM/D.

STYLES ON PAGE 2

DOCUMENT NUMBER:	98ASB42985B	Electronic versions are uncontrolled except when accessed directly from the Document Repository. Printed versions are uncontrolled except when stamped "CONTROLLED COPY" in red.
DESCRIPTION:	SC-88/SC70-6/SOT-363	PAGE 1 OF 2

onsemi and onsemi are trademarks of Semiconductor Components Industries, LLC dba onsemi or its subsidiaries in the United States and/or other countries. onsemi reserves the right to make changes without further notice to any products herein. onsemi makes no warranty, representation or guarantee regarding the suitability of its products for any particular purpose, nor does onsemi assume any liability arising out of the application or use of any product or circuit, and specifically disclaims any and all liability, including without limitation special, consequential or incidental damages. onsemi does not convey any license under its patent rights nor the rights of others.

SC-88/SC70-6/SOT-363
CASE 419B-02
ISSUE Y

DATE 11 DEC 2012

STYLE 1: PIN 1. EMITTER 2 2. BASE 2 3. COLLECTOR 1 4. EMITTER 1 5. BASE 1 6. COLLECTOR 2	STYLE 2: CANCELLED	STYLE 3: CANCELLED	STYLE 4: PIN 1. CATHODE 2. CATHODE 3. COLLECTOR 4. EMITTER 5. BASE 6. ANODE	STYLE 5: PIN 1. ANODE 2. ANODE 3. COLLECTOR 4. EMITTER 5. BASE 6. CATHODE	STYLE 6: PIN 1. ANODE 2 2. N/C 3. CATHODE 1 4. ANODE 1 5. N/C 6. CATHODE 2
STYLE 7: PIN 1. SOURCE 2 2. DRAIN 2 3. GATE 1 4. SOURCE 1 5. DRAIN 1 6. GATE 2	STYLE 8: CANCELLED	STYLE 9: PIN 1. EMITTER 2 2. EMITTER 1 3. COLLECTOR 1 4. BASE 1 5. BASE 2 6. COLLECTOR 2	STYLE 10: PIN 1. SOURCE 2 2. SOURCE 1 3. GATE 1 4. DRAIN 1 5. DRAIN 2 6. GATE 2	STYLE 11: PIN 1. CATHODE 2 2. CATHODE 2 3. ANODE 1 4. CATHODE 1 5. CATHODE 1 6. ANODE 2	STYLE 12: PIN 1. ANODE 2 2. ANODE 2 3. CATHODE 1 4. ANODE 1 5. ANODE 1 6. CATHODE 2
STYLE 13: PIN 1. ANODE 2. N/C 3. COLLECTOR 4. EMITTER 5. BASE 6. CATHODE	STYLE 14: PIN 1. VREF 2. GND 3. GND 4. IOUT 5. VEN 6. VCC	STYLE 15: PIN 1. ANODE 1 2. ANODE 2 3. ANODE 3 4. CATHODE 3 5. CATHODE 2 6. CATHODE 1	STYLE 16: PIN 1. BASE 1 2. EMITTER 2 3. COLLECTOR 2 4. BASE 2 5. EMITTER 1 6. COLLECTOR 1	STYLE 17: PIN 1. BASE 1 2. EMITTER 1 3. COLLECTOR 2 4. BASE 2 5. EMITTER 2 6. COLLECTOR 1	STYLE 18: PIN 1. VIN1 2. VCC 3. VOUT2 4. VIN2 5. GND 6. VOUT1
STYLE 19: PIN 1. IOUT 2. GND 3. GND 4. V CC 5. V EN 6. V REF	STYLE 20: PIN 1. COLLECTOR 2. COLLECTOR 3. BASE 4. EMITTER 5. COLLECTOR 6. COLLECTOR	STYLE 21: PIN 1. ANODE 1 2. N/C 3. ANODE 2 4. CATHODE 2 5. N/C 6. CATHODE 1	STYLE 22: PIN 1. D1 (i) 2. GND 3. D2 (i) 4. D2 (c) 5. VBUS 6. D1 (c)	STYLE 23: PIN 1. Vn 2. CH1 3. Vp 4. N/C 5. CH2 6. N/C	STYLE 24: PIN 1. CATHODE 2. ANODE 3. CATHODE 4. CATHODE 5. CATHODE 6. CATHODE
STYLE 25: PIN 1. BASE 1 2. CATHODE 3. COLLECTOR 2 4. BASE 2 5. EMITTER 6. COLLECTOR 1	STYLE 26: PIN 1. SOURCE 1 2. GATE 1 3. DRAIN 2 4. SOURCE 2 5. GATE 2 6. DRAIN 1	STYLE 27: PIN 1. BASE 2 2. BASE 1 3. COLLECTOR 1 4. EMITTER 1 5. EMITTER 2 6. COLLECTOR 2	STYLE 28: PIN 1. DRAIN 2. DRAIN 3. GATE 4. SOURCE 5. DRAIN 6. DRAIN	STYLE 29: PIN 1. ANODE 2. ANODE 3. COLLECTOR 4. EMITTER 5. BASE/ANODE 6. CATHODE	STYLE 30: PIN 1. SOURCE 1 2. DRAIN 2 3. DRAIN 2 4. SOURCE 2 5. GATE 1 6. DRAIN 1

Note: Please refer to datasheet for style callout. If style type is not called out in the datasheet refer to the device datasheet pinout or pin assignment.

DOCUMENT NUMBER:	98ASB42985B	Electronic versions are uncontrolled except when accessed directly from the Document Repository. Printed versions are uncontrolled except when stamped "CONTROLLED COPY" in red.
DESCRIPTION:	SC-88/SC70-6/SOT-363	PAGE 2 OF 2

onsemi and **ONSEMI** are trademarks of Semiconductor Components Industries, LLC dba **onsemi** or its subsidiaries in the United States and/or other countries. **onsemi** reserves the right to make changes without further notice to any products herein. **onsemi** makes no warranty, representation or guarantee regarding the suitability of its products for any particular purpose, nor does **onsemi** assume any liability arising out of the application or use of any product or circuit, and specifically disclaims any and all liability, including without limitation special, consequential or incidental damages. **onsemi** does not convey any license under its patent rights nor the rights of others.

onsemi, **Onsemi**, and other names, marks, and brands are registered and/or common law trademarks of Semiconductor Components Industries, LLC dba "**onsemi**" or its affiliates and/or subsidiaries in the United States and/or other countries. **onsemi** owns the rights to a number of patents, trademarks, copyrights, trade secrets, and other intellectual property. A listing of **onsemi**'s product/patent coverage may be accessed at www.onsemi.com/site/pdf/Patent-Marking.pdf. **onsemi** reserves the right to make changes at any time to any products or information herein, without notice. The information herein is provided "as-is" and **onsemi** makes no warranty, representation or guarantee regarding the accuracy of the information, product features, availability, functionality, or suitability of its products for any particular purpose, nor does **onsemi** assume any liability arising out of the application or use of any product or circuit, and specifically disclaims any and all liability, including without limitation special, consequential or incidental damages. Buyer is responsible for its products and applications using **onsemi** products, including compliance with all laws, regulations and safety requirements or standards, regardless of any support or applications information provided by **onsemi**. "Typical" parameters which may be provided in **onsemi** data sheets and/or specifications can and do vary in different applications and actual performance may vary over time. All operating parameters, including "Typicals" must be validated for each customer application by customer's technical experts. **onsemi** does not convey any license under any of its intellectual property rights nor the rights of others. **onsemi** products are not designed, intended, or authorized for use as a critical component in life support systems or any FDA Class 3 medical devices or medical devices with a same or similar classification in a foreign jurisdiction or any devices intended for implantation in the human body. Should Buyer purchase or use **onsemi** products for any such unintended or unauthorized application, Buyer shall indemnify and hold **onsemi** and its officers, employees, subsidiaries, affiliates, and distributors harmless against all claims, costs, damages, and expenses, and reasonable attorney fees arising out of, directly or indirectly, any claim of personal injury or death associated with such unintended or unauthorized use, even if such claim alleges that **onsemi** was negligent regarding the design or manufacture of the part. **onsemi** is an Equal Opportunity/Affirmative Action Employer. This literature is subject to all applicable copyright laws and is not for resale in any manner.

ADDITIONAL INFORMATION

TECHNICAL PUBLICATIONS:

Technical Library: www.onsemi.com/design/resources/technical-documentation
onsemi Website: www.onsemi.com

ONLINE SUPPORT: www.onsemi.com/support

For additional information, please contact your local Sales Representative at www.onsemi.com/support/sales