



Feature

- Max.Switching Capability:35A , Low Power 0.6W/0.8W
- Microminiature, Standard PCB Type
- High Vibration and Shock Resistance

Contact Capacity

Model	SARD
Nominal Load(Res.)	20A 14VDC
Max.Switching Current	35A (14VDC)
Max.Switching Voltage	30VDC

Characteristic Data

Contact Material	Silver Alloy	
Initial Contact Resistance	100mΩ Max. (AT 1A/6VDC)	
Operate Time	10msec. Max.	
Release Time	5msec. Max.	
Initial Insulation Resistance	100MΩ Min.(DC500V)	
Initial Dielectric Strength	OP/OP :	AC500V , 50/60Hz 1min.
	IP/OP :	AC500V , 50/60Hz 1min.
Vibration Resistance	Misoperation	10 ~ 500Hz , NO-10g 10 ~ 500Hz , NC-5g
	Functional	100g Min.
Shock Resistance	Functional	100g Min.
	Misoperation	20g for NO/11ms. 5g for NC/11ms.
Endurance(operations)	Mechanical (10,800ops./h)	10,000,000
	Electrical (720ops./h)	100,000
Ambient Temperature	-40°C ~ +125°C (no condensation)	
Unit Weight	ca 6.0g	

Contact Data

Contact Voltage	Load Type		Contact Current(A)		Duty Factor		Electrical Endurance
			NO	NC	on (S)	off (S)	
14VDC	Res.	on	20	10	2	2	2x10 ⁵
		off	20	10			
	Res. ⁽¹⁾	on	30	—	2	2	1x10 ⁵
		off	30	—			
	Motor ⁽¹⁾	on	40 ⁽²⁾	—	0.2	2	2x10 ⁵
		off	15 ⁽²⁾	—			

Contact Voltage	Load Type		Contact Current(A)		Duty Factor		Electrical Endurance
			NO	NC	on (S)	off (S)	
			14VDC	Lamp ⁽¹⁾	on	90 ⁽³⁾	
off	8.8						
Lamp ⁽¹⁾	on	6x21W		—	1	6	1x10 ⁵
	off						
Flashlight ⁽¹⁾	on	3x21W		—	0.365	0.365	2x10 ⁶
	off						

Note: (1) Material of spring is high conductive
 (2) It means the surge current of motor LRA
 (3) Initial peak current of filament

Coil Data (at 20°C)

Nominal Voltage (VDC)	Nominal Current (VDC)	Coil Resistance ± 10% (Ω)	Max continuous Voltage	Pick-up Voltage (Max.)	Drop-out Voltage (Min.)	Nominal Operating Power
5	120.00	42	130% of nominal voltage	60% of nominal voltage	10% of nominal voltage	ca 0.60W
6	100.00	60				
9	66.67	135				
12	50.00	240				
18	33.33	540				
24	25.00	960				
5	160.00	31	130% of nominal voltage	57.5% of nominal voltage	10% of nominal voltage	ca 0.80W
6	133.33	45				
9	89.00	101				
12	66.67	180				
18	44.44	405				
24	33.33	720				

Ordering Information

Nomenclature						
SARD	-S	-1	12	D	M	1-XX
Special Parameter : Nil-Standard Type, Letter or Number-Special requirement						
Contact Material :						
Form C		Form A		Form B		
Nil-AgSnO2	φ3.0	Nil-AgSnO2	φ3.2	Nil-AgSnO2	φ3.2	
1-AgCdO	φ2.8	1-AgCdO	φ3.2	1-AgCdO	φ3.2	
2-AgSnO2	φ2.8	2-AgSnO2	φ2.8	2-AgSnO2	φ2.8	
3-AgCdO	φ3.0	3-AgCdO	φ2.8	3-AgCdO	φ2.8	
4-3 Compounds φ3.0						
5-Cu plated with La φ3.0						
1.stationary contact specified:φ3.0 φ2.8moveable contact fit with φ2.8 stationary contact, other moveable contacts are all suitable with φ3.0 stationary contacts.						
2.moveable contact of AgCdO fit with AgCdO, other moveable contacts are all suitable with AgSnO2.						
Contact Form : Nil-Form C , B-Form B , M-Form A						
Coil Power : D-0.6W , H-0.8W						
Coil Voltage(VDC) : 05 , 06 , 09 , 12 , 24						
Number of Poles : 1-1Pole						
Protective Construction : S-Fluxproof , SH-sealed type washable						
Type Designation : SARD						

Outline Dimensions, Wiring Diagram, PCB Layout (Unit:mm)

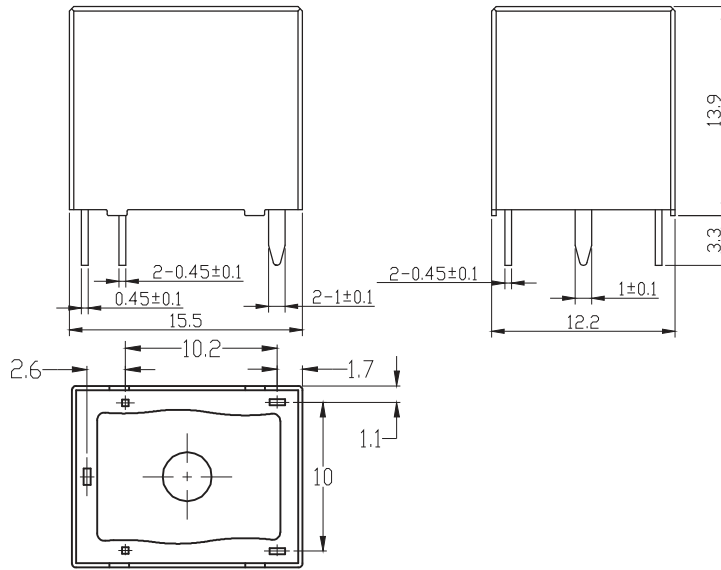

Unless otherwise specified:
 If dimension < 1 mm, tolerance: ±0.2 mm;
 If dimension 1-5 mm, tolerance: ±0.3 mm;
 If dimension > 5 mm, tolerance: ±0.4 mm;
 Note: 1, Extended terminal dimension is dimension before soldering.
 2, Tolerance of mounting holes: ±0.1mm

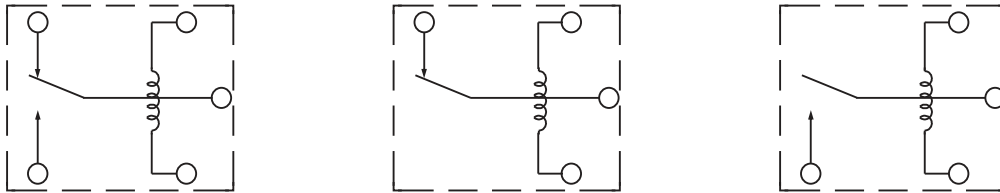

Wiring Diagram(Bottom View)

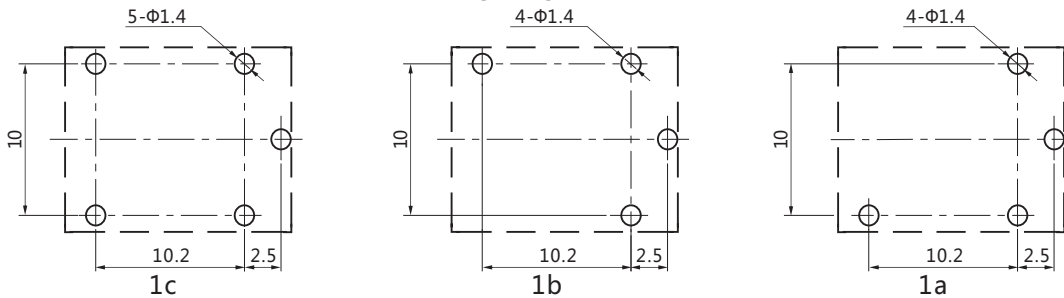

PCB Layout(Bottom View)

Typical Applications

- Auto door lock motor control, home appliances, office equipments, anti-thief system, etc.

Characteristic Curves

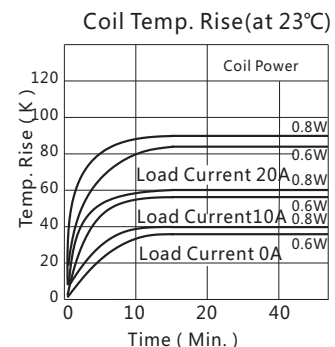
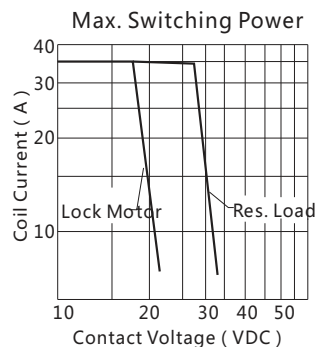
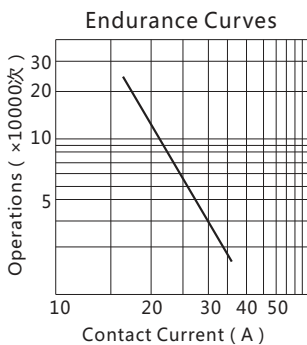

Disclaimer :

This datasheet is the customers' reference. All the specification are subject to change without notice.
 We could not evaluate all the performance and parameters for every possible application. Thus the users should be in a right position to choose the suitable product for their own application. If there is any query, please contact Sanyou for technical service.
 However it is the users' responsibility to determine which product should be used only.