

成型尺寸	公差
5mm 以下	±0.2
5~20mm	±0.3
20~40mm	±0.4
40~60mm	±0.5
60~100mm	±0.8
100mm 以上	±1.0

REVISIONS			
REV	DESCRIPTION	DATE	BY

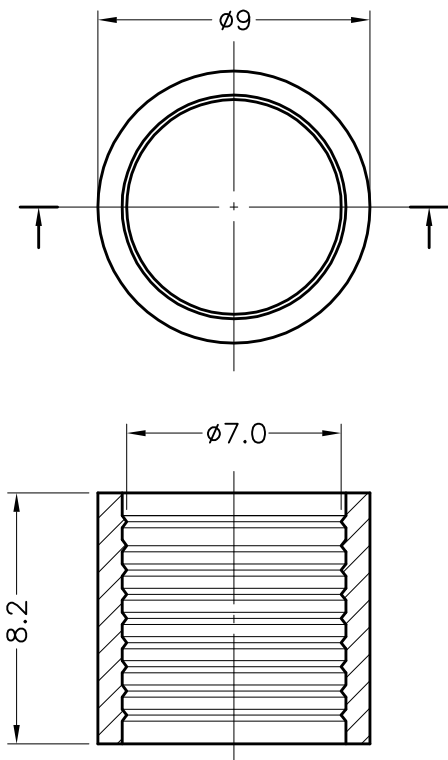

PART NO.	COLOR
LC5-1T	BLACK
LC5-1T(N)	NATURAL

QMF22 Component - Plastics

Wednesday, September 15, 2004

B4 1938

E I DUPONT DE NEMOURS & CO INC

ENGINEERING POLYMERS CHESTNUT RUN PLAZA PO BOX 80713 WILMINGTON DE 19880

Material Designation: **101(+)(F1), 101F(+)(F1), 101L(+)(F1), E101(+)(F1), E101L(F1), 132F(+)(F1), 135F(+)(F1)**

Product Description: Polyamide 66 (PA66), designated "Zytel" furnished as pellets.

Color	Min. Thick (mm)	Flame Class	HWI	HAI	RTI Elec	RTI Imp	RTI Str	IBC GWIT	IBC GWFI
ALL	0.71	V-2	4	0	130	75	85	725	960
	1.5	V-2	3	0	130	75	85	750	960
	3	V-2	2	0	130	75	85	800	960
	6	V-2	2	0	130	75	85	800	960

CTI: 0

HVTR: 0

D495: 6

IBC Bell Pressure (CC):

Delicate Strength (GV/mm): 13

Volume Ratio (V/V): (0.01mm³/mm³): 14

Dimensional Stability (%):

ISO Tensile Strength (MPa):

ISO Flexural Strength (MPa):

ISO Heat Deflection (CC):

ISO Tensile Impact (kJ/m²):

ISO Izod Impact (kJ/m²):

ISO Charpy Impact (kJ/m²):

(1) Virgin and regrind up to 50% by weight inclusive, have the same basic material characteristics.

(1) Suitable for outdoor use with respect to exposure to Ultraviolet Light, Water Exposure and Immersion in accordance with UL 746C.

NOTE (1) Material designations that are color pigmented may be followed by suffix letters and numbers. (2) Material designations may be prefixed by "ZY1" or "MIN" or "ZEN" or "DEL" or "CRA" or "RYN".

Report Date: 7/29/1996

Underwriters Laboratories Inc®

UL94 small-scale test data does not pertain to building materials, furnishings and related contents. UL 94 small-scale test data is intended solely for determining the flammability of plastic materials used in components and parts of end product designs and assemblies, where the acceptability of the combination is determined by UL.

<p>康揚企業股份有限公司 KANG YANG HARDWARE ENTERPRISE CO., LTD. 東莞康揚塑膠五金電子廠 DONG GUAN KANG YANG PLASTIC HARDWARE COMPANY 康哲電腦配件(吳江)有限公司 KANG CHE COMPUTER COMPONENTS(WUJIANG) CO.,LTD.</p>	TITLE	LED座套	產品規格圖面	
	MATERIAL	NYLON 66 UL94V-2	DATE	2002.02.27
	FINISH		DRAWN	S.J.C.
	COLOR	SEE ABOVE	CHECK	
PART NUMBER	SEE ABOVE	DRAWING NUMBER	LC5-1T	
UNLESS OTHERWISE SPECIFIED TOLERANCE	SEE ABOVE	APPROVED		
SIZE	A4	SCALE	4:1	
UNIT	mm	REV	A	