

PAGE 1/2

ISSUE 22-03-22

SERIE : SPnT

PART NUMBER : R574102435

## RF CHARACTERISTICS

Number of ways : **4**  
 Frequency range : **0 - 12.4 GHz**  
 Impedance : **50 Ohms**

Frequency (GHz)	DC - 3	3 - 8	8 - 12.4
VSWR max	<b>1.20</b>	<b>1.35</b>	<b>1.50</b>
Insertion loss max	<b>0.20 dB</b>	<b>0.35 dB</b>	<b>0.50 dB</b>
Isolation min	<b>80 dB</b>	<b>70 dB</b>	<b>60 dB</b>
Average power (*)	<b>400 W</b>	<b>250 W</b>	<b>200 W</b>

TERMINATION IMPEDANCE : **50 Ohms**  
 TERM. AVG. POWER AT 25° C : **1 W per termination / 3 W total power**

## ELECTRICAL CHARACTERISTICS

Actuator : **NORMALLY OPEN**  
 Nominal current \*\* : **250 mA**  
 Actuator voltage (Vcc) : **12V (10.2 to 13V) / NEGATIVE COMMON**  
 Terminals : **25 pins D-SUB male connector**

## MECHANICAL CHARACTERISTICS

Connectors : **N female per MIL-C 39012**  
 Life : **2 million cycles per position**  
 Switching Time\*\*\* : **< 15 ms**  
 Construction : **Splashproof**  
 Weight : **< 460 g**

## ENVIRONMENTAL CHARACTERISTICS

Operating temperature range : **-40°C to +85°C**  
 Storage temperature range : **-55°C to +85°C**

(\* Average power at 25°C per RF Path)

(\*\* At 25° C ±10%)

(\*\*\* Nominal voltage ; 25° C)



PAGE 2/2

ISSUE 22-03-22

SERIE : SPnT

PART NUMBER : R574102435

**DRAWING**

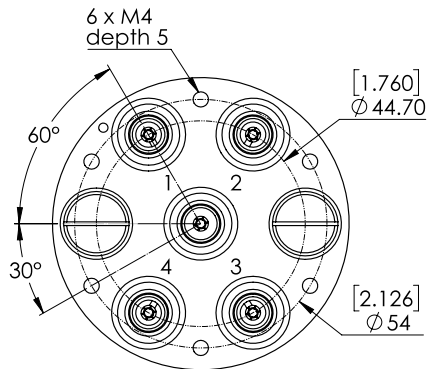

Voltage	RF Continuity
-C +1	IN ↔ 1
-C +2	IN ↔ 2
-C +3	IN ↔ 3
-C +4	IN ↔ 4

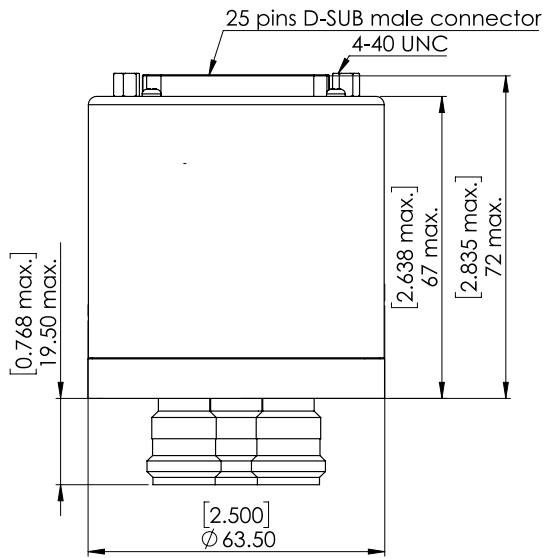

General tolerances : ±0,5 mm [0,02 in]

**LABEL**

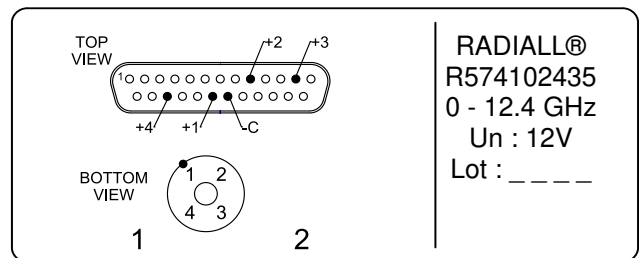

RADIALL®  
 R574102435  
 0 - 12.4 GHz  
 Un : 12V  
 Lot : \_ \_ \_ \_



**SCHEMATIC DIAGRAM**

