

Miniature linear battery management chip

Summary

TP4054 is a perfect single-chip constant current / constant voltage linear power management chip for lithium-ion batteries. It's portable and small in size. Use. What's more, TP4054 is specially designed for USB power supply specifications. Due to the internal MOSFET structure, external resistance and blocking diode are not required in application. In high energy operation and high peripheral temperature, the thermal feedback can control the charging current to reduce the chip temperature.

The charging voltage is limited to 4.2V and the charging current is regulated by resistance. After reaching the target charging voltage, when the charging current is reduced to 1 / 10 of the set value, The TP4054 will automatically end the charging process. TP4054 can also be set in the stop working state to reduce the power supply current to  $\mu A 25$ .

TP4054 ensures that the chip will automatically enter the protection state when the battery is connected reversely, so as to ensure that the IC will not be broken down and lead to battery self discharge accidents. Other features include: charging current monitoring, input low voltage blocking, automatic recharging and signs of full and start charging.

Characteristic

- ◆ Instantaneous withstand voltage 11V
- ◆ The charging current can reach 500mA by programming
- ◆ No MOSFET, sensing resistor and blocking diode are required
- ◆ Full linear charging management of lithium-ion battery with small size
- ◆ The constant current / constant voltage operation and thermal regulation make the battery management more effective, and there is no danger of excessive heat
- ◆ Single chip lithium ion battery management from USB interface
- ◆ 4.2V preset charging voltage with an accuracy of  $\pm 1\%$
- ◆ Monitoring of charging current output
- ◆ Charging status indicator
- ◆ 1 / 10 charging current termination  
Stop work at  $25 \mu A$  current
- ◆ 2.9v trickle charging threshold voltage  
Soft start limits surge current  
Battery reverse connection protection

Application

- ◆ Mobile phone, PDA, MP3
- ◆ Bluetooth application

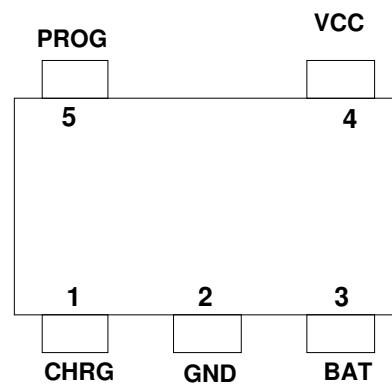

TP4054 is packaged in SOT-23-5L

Typical application circuit

Basic circuit

Single lithium battery charger

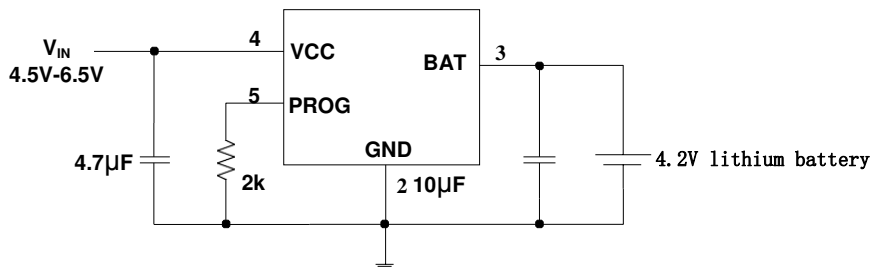

Typical circuit

USB / adapter power lithium charger

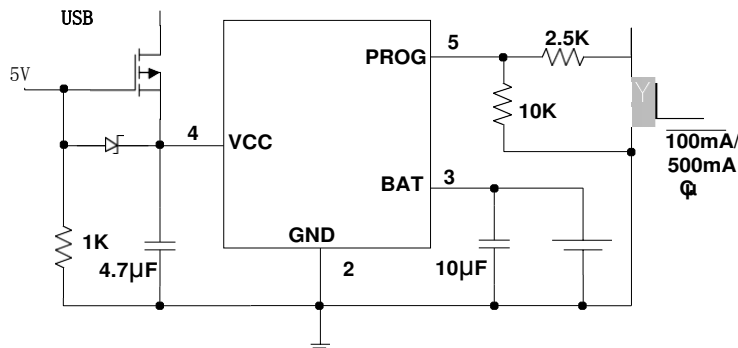

Fully functional single lithium battery charger

Lithium charger with reverse input protection

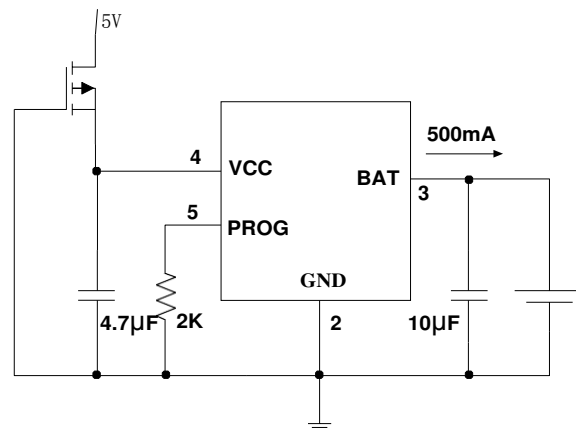
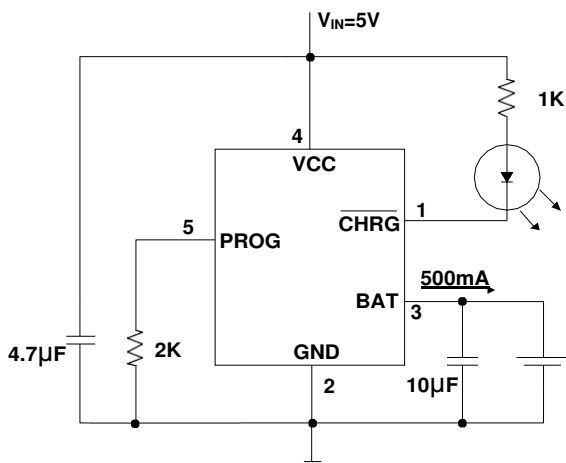

Miniature linear battery management chip

Pin description

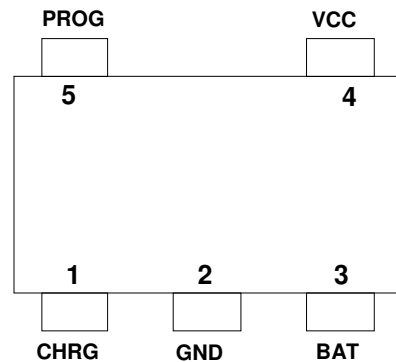

Pin number	Pinname	describe
1	CHRG	Open drain state of charge output.
2	GND	Ground terminal.
3	BAT	Charging current output.
4	VCC	Positive input voltage.
5	PROG	Charging current programming, charging current monitoring and closing terminal.

Pin function

**CHRG (pin 1):** open drain state output. When charging, the CHRG port is placed at low potential by a built-in n-channel MOSFET. When the charging is completed, the CHRG shows a high resistance state. When TP4054 detects low electrical locking condition, CHRG presents high resistance state. When a 1 is connected between bat pin and ground  $\mu\text{F}$  capacitance, you can complete the battery is connected to good indication, when there is no battery, LED light will flash quickly.

**GND (pin 2):** ground terminal.

**Bat (pin 3):** charging current output. The charging current is supplied to the battery and the floating voltage is controlled to reach 4.2V. When the battery is reversely connected, the internal protection circuit protects the ESD diode of Vbat from being burnt out, and a current of about 0.7mA is formed between GND and bat.

**VCC (pin 4):** provides positive voltage input. Power the charger. VCC can be 4.25v to 6.5V and must have at least 1 $\mu\text{B}$ ypass capacitance of F. If

When the voltage difference between bat pin end voltage and VCC is less than 30mV, TP4054 enters shutdown state and bat current drops to 2 $\mu\text{A}$  Below a.

**Prog (pin 5):** charging current programming, charging current monitoring and closing terminal. The charging current is controlled by a resistance connected to the ground with an accuracy of 1%. This port provides 1V voltage at constant charging current. 80)llowing formula can be used to calculate the voltage of  $R = 80$ ) in all charging states  $\times 1000$ . The prog port can also be used to turn off the charger. The programming resistor can be separated from the ground terminal through the pull-up 2 $\mu\text{A}$  current source raises prog Port voltage. When the limit shutdown voltage of 1.21v is reached, the actuator will stop working, and the charging will end, and the input current will drop to 25 $\mu\text{A}$ . The clamp off voltage of this port is about 2.4V. Supplying this port with a voltage above the pinch off voltage will result in a high current of 1.5 ma. The combination of prog and ground terminal will make the charger return to normal state.

characteristic curve

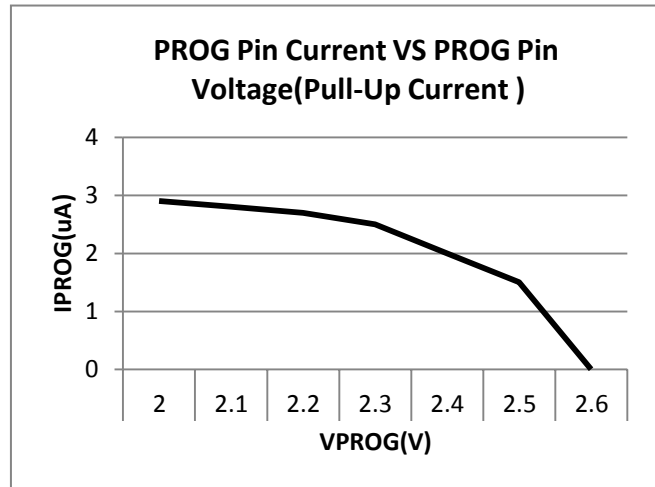
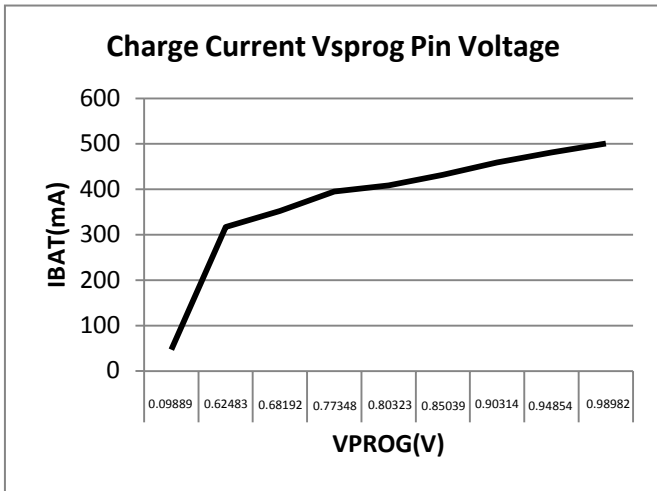

Relation curve between charging current and prog pin voltage      Relation between prog pin and pull current

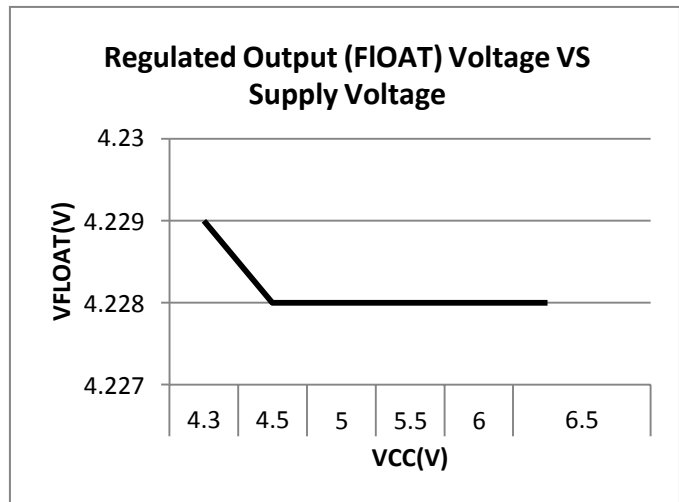
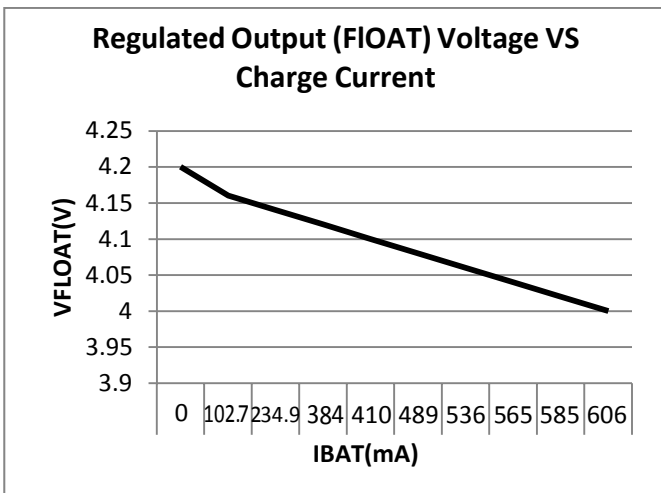

Relationship between floating charging voltage and charging current

Relationship between floating charge voltage and power supply voltage

Miniature linear battery management chip

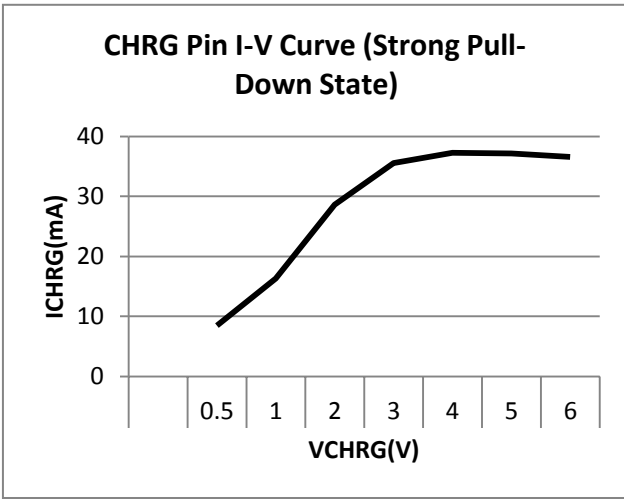

I-V curve

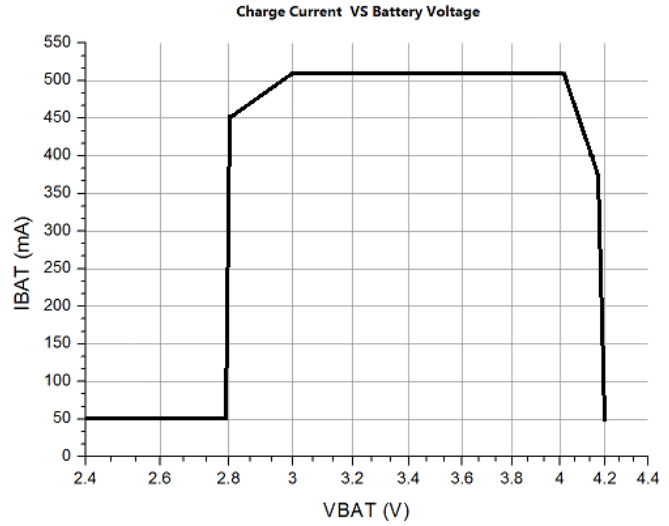

Relationship between charging voltage and charging current

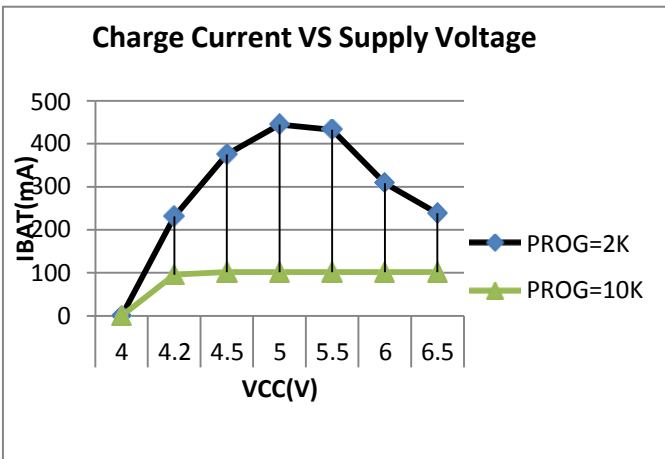

Relationship between charging current and supply voltage

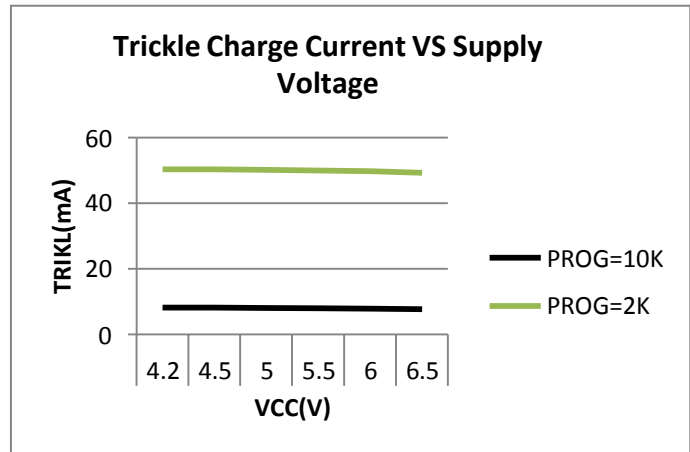

Relationship between trickle current and supply voltage

### Working principle

TP4054 is a single lithium ion battery charger with constant current / constant voltage algorithm. It can provide a maximum charging current of about 500mA (with the help of a thermally designed PCB layout) and an internal p-channel power MOSFET and thermal regulation circuit. There is no need to isolate diodes or external current detection resistors.

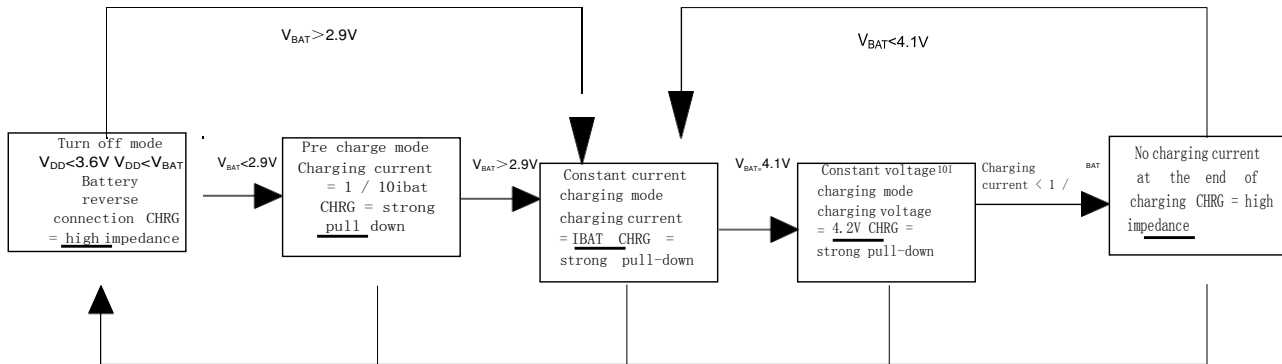

### Normal charging cycle

A charging cycle begins when the VCC pin voltage rises above the UVLO threshold level and a set resistor with an accuracy of 1% is connected between the prog pin and the ground, or when a battery is connected to the charger output. If the bat pin level is lower than 2.9v, the charger enters trickle charging mode. In this mode, TP4054 provides about 1 / 10 of the set charging current, In order to raise the current to a safe level to achieve full current charging.

When the bat pin voltage rises to more than 2.9v, the charger will enter the constant current mode and provide the battery with a constant warm current. When the bat pin voltage reaches the final floating charge voltage (4.2V), it enters the constant voltage mode and the charging current begins to decrease. When the charging current drops to 1 / 10 of the set value, the charging cycle ends.

### Setting of charging current

The charging current is set using a resistor connected between the prog pin and ground. Current charging current is 1000 times of the output current of prog pin. The following formula is used to calculate the resistor and charge current:

$$R_{PROG} = \frac{1000V}{I_{CHG}} \cdot I_{CHG} = \frac{1000V}{R_{PROG}}$$

The charging current output from bat pin can be determined at any time by monitoring the voltage of prog pin. The formula is as follows:

$$I_{BAT} = \frac{V_{PROG}}{R_{PROG}} \cdot 1000$$

## Miniature linear battery management chip

The relationship between rprog and charging current is determined as follows:

RPROG(K)	IBAT(mA)
1.4	600
2	500
2.2	400
3	300
5	200
10	100

### Battery reverse connection protection function

P4054 has the function of lithium battery reverse connection protection. The positive and negative poles of the gear lithium battery are reversely connected to the current output pin of ltc4054es5-4.2tr. TP4054 will shut down to display the fault status, without charging current. In the case of reverse connection, the power supply voltage should be about 5V of standard voltage and should not exceed 8V. If the power supply voltage is too high, the chip voltage difference will exceed 10V when the battery voltage is reversed.

### State of charge indicator (CHRG)

TP4054 has an open drain state indicating the output "CHRG". When the charger is in charge, the CHRG is pulled to low power.

In other states, CHRG is in high resistance state. When the battery is not connected to the charger, the CHRG output pulse signal indicates that no battery is installed. When the external capacitance of bat pin at the battery connection terminal is 10uF, the CHRG flicker cycle is about 0.5-2 seconds. When the state indication function is not used, the unused state indication output terminal is connected to the ground.

Status of charging indicator with	CHRG
Normal state of	Everbright
Battery full state	Extinguish
Battery reverse connection, power supply under voltage	Extinguish
No battery power on	twinkle

### Thermal limit

If the chip temperature attempts to rise above the preset value of about 120 °C, an internal thermal feedback loop will reduce the set charging current. This function prevents

The TP4054 overheats and allows the user to increase the upper limit of the power handling capacity of a given circuit board without the risk of damaging the TP4054.

Under the premise that the charger will automatically reduce the current under the worst-case conditions, the charging current can be set according to the typical (not the worst-case) ambient temperature. Power considerations for SOT-23 will be further discussed in the "thermal considerations" section.

Miniature linear battery management chip

Structure diagram

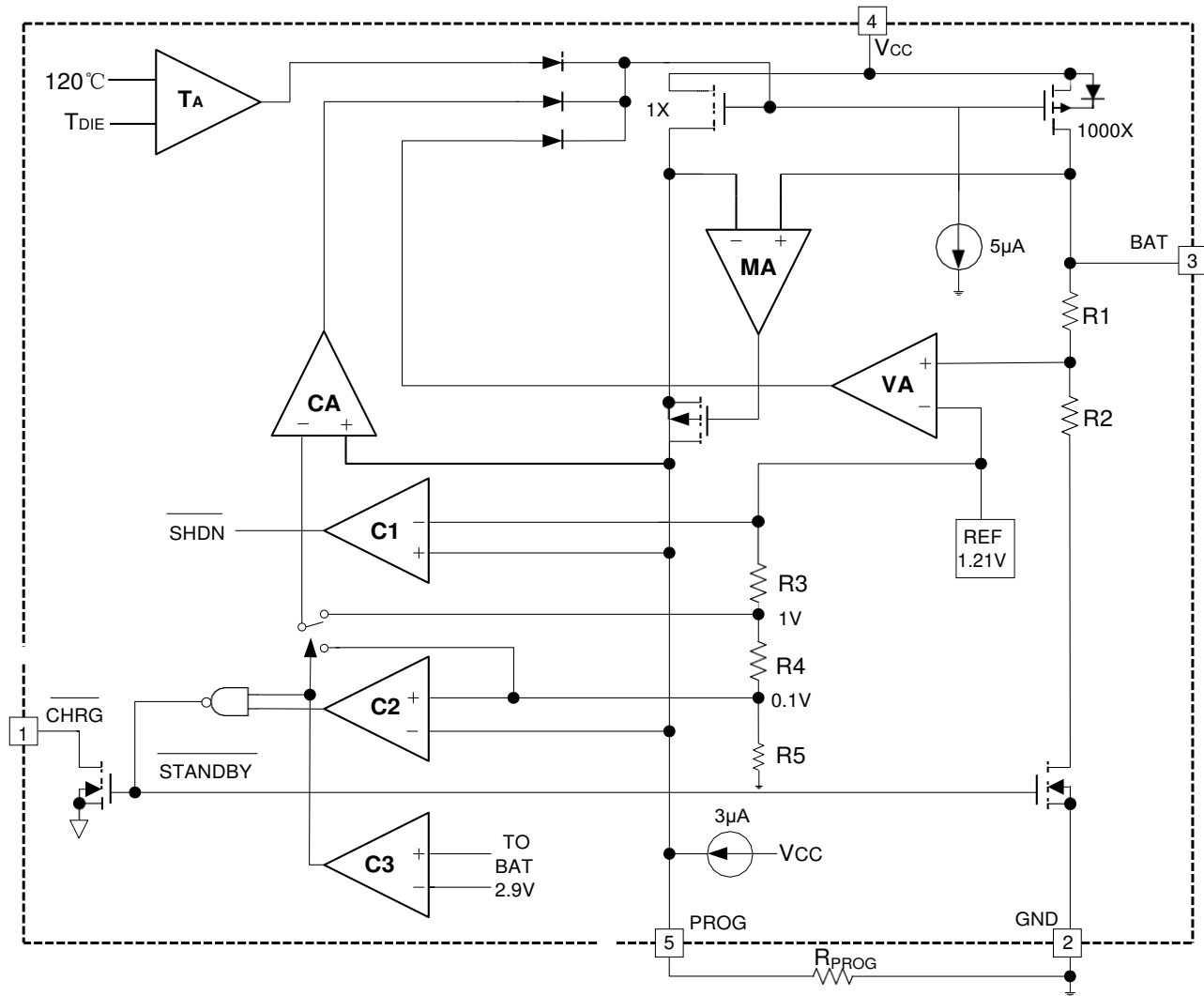



Miniature linear battery management chip

Maximum rating (Note 1)

Symbol	Symbol description	Range	Company
V <sub>CC</sub>	input voltage	V <sub>SS</sub> -0.3~V <sub>SS</sub> +7	V
V <sub>PROG</sub>	Prog terminal voltage	V <sub>SS</sub> -0.3~V <sub>SS</sub> +0.3	V
V <sub>BAT</sub>	Bat terminal voltage	V <sub>SS</sub> -0.3~7	V
V <sub>CHRG</sub>	CHRG terminal voltage	V <sub>SS</sub> -0.3~V <sub>SS</sub> +10	V
P <sub>DMAX</sub>	power waste	250	mW
I <sub>BAT</sub>	Bat terminal current	500	mA
I <sub>PROG</sub>	Prog terminal current	800	μA
V <sub>ESD</sub>	ESD capability in human mode	4	kV
Latch-Up	Impedance current between pin pins	400	mA
T <sub>OPA</sub>	Working peripheral temperature	-40~+85	°C
T <sub>STR</sub>	Storage temperature	-65~+125	°C

Note 1: devices beyond the maximum range may be damaged. The device can work within the recommended operating range, but its characteristics are not guaranteed. The DC and AC characteristics indicated by electrical characteristics are measured under specific conditions, and their characteristics can be guaranteed. This characteristic assumes that the device operates within the recommended operating range. The performance is not guaranteed if the characteristics are not shown. The typical value is the best performance point.

## Miniature linear battery management chip

### Electrical characteristics

The test condition was 25 °C

Symbol	Symbol description	condition	minimum value	Typical value	Maximum	Company
V <sub>CC</sub>	input voltage		4.2		6.5	V
I <sub>CC</sub>	Input current	Charging mode (R <sub>PROG</sub> = 10K Ω)		300	2000	μA
		standby mode		200	500	μA
		Turn off mode (R <sub>PROG</sub> is not connected, V <sub>CC</sub> < V <sub>bat</sub> or V <sub>CC</sub> < V <sub>UV</sub> )		25	50	μA
V <sub>FLOAT</sub>	Output control voltage	0°C<Ta<85°C, I <sub>bat</sub> =40mA	4.158	4.2	4.242	V
I <sub>BAT</sub>	Bat terminal current	R <sub>PROG</sub> = 10K, current mode	93	100	107	mA
		R <sub>PROG</sub> = 2K, current mode	465	500	535	mA
		V <sub>BAT</sub> = 4.2V, standby mode	0	-2.5	-6	μA
		Turn off mode		6	10	μA
		V <sub>BAT</sub> = - 4V, battery reverse mode		0.7		mA
V <sub>CC</sub> = 0V, sleep mode		6	10	μA		
I <sub>TRIKL</sub>	trickle charge current	V <sub>BAT</sub> <V <sub>TRIKL</sub> , R <sub>PROG</sub> =2K	40	50	60	mA
V <sub>TRIKL</sub>	Trickle charging limit voltage	R <sub>PROG</sub> = 10K, V (m244) increased	2.8	2.9	3.0	V
V <sub>TRHYS</sub>	Trickle charge hysteresis voltage	R <sub>PROG</sub> =10K	60	80	110	mV
V <sub>UV</sub>	Low power blocking threshold voltage of power supply	increased from low	3.7	3.8	3.93	V
V <sub>UVHYS</sub>	Low threshold hysteresis voltage of power supply		150	200	300	mV
V <sub>MSD</sub>	Manual turn off threshold voltage	Prog feet up	1.15	1.21	1.30	V
		Prog feet up	0.9	1.0	1.1	V
V <sub>ASD</sub>	threshold value of the working voltage of the machine is (V) - 44	V <sub>BAT</sub> from low to high	70	100	140	mV
		I <sub>BAT</sub> from high to low	5	30	50	mV
I <sub>TERM</sub>	C / 10 terminal threshold current	R <sub>PROG</sub> =10K	0.085	0.10	0.115	mA/
		R <sub>PROG</sub> =2K	0.085	0.10	0.115	mA
V <sub>PROG</sub>	Prog terminal voltage	R <sub>PROG</sub> = 10K, current mode	0.93	1.0	1.07	V
V <sub>CHRG</sub>	Minimum output voltage at CHRG terminal	I <sub>CHRG</sub> =5mA		0.35	0.6	V
ΔV <sub>RECG</sub>	Battery recharge hysteresis voltage	V <sub>FLOAT</sub> -V <sub>RECHRG</sub>		100	200	mV
t <sub>RECHG</sub>	Filtering time of charging comparator	V <sub>BAT</sub> from high to low	0.8	1.8	4	mS
t <sub>TERM</sub>	Stop comparator filtering time	I <sub>BAT</sub> fell below I <sub>TC</sub> / 10	0.63	1.4	3	mS
I <sub>PROG</sub>	Pull up current of prog pin			2		μA

Miniature linear battery management chip

Package description: SOT23-5L

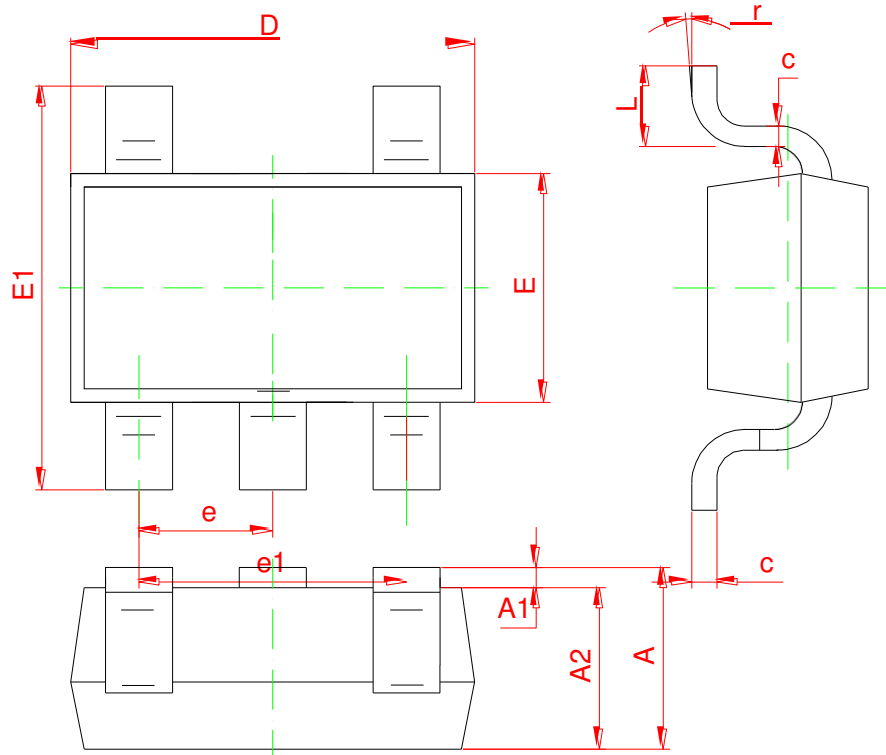

Symbol	Dimensions In Millimeters		Dimensions In Inches	
	Min	Max	Min	Max
A	1.050	1.250	0.041	0.049
A1	0.000	0.100	0.000	0.004
A2	1.050	1.150	0.041	0.045
b	0.300	0.500	0.012	0.020
c	0.100	0.200	0.004	0.008
D	2.820	3.020	0.111	0.119
E	1.500	1.700	0.059	0.067
E1	2.650	2.950	0.104	0.116
e	0.950 (BSC)		0.037 (BSC)	
e1	1.800	2.000	0.071	0.079
L	0.300	0.600	0.012	0.024
r	0°	8°	0°	8°