

# TeraRanger Hub Evo

by TERABEE 

---

---

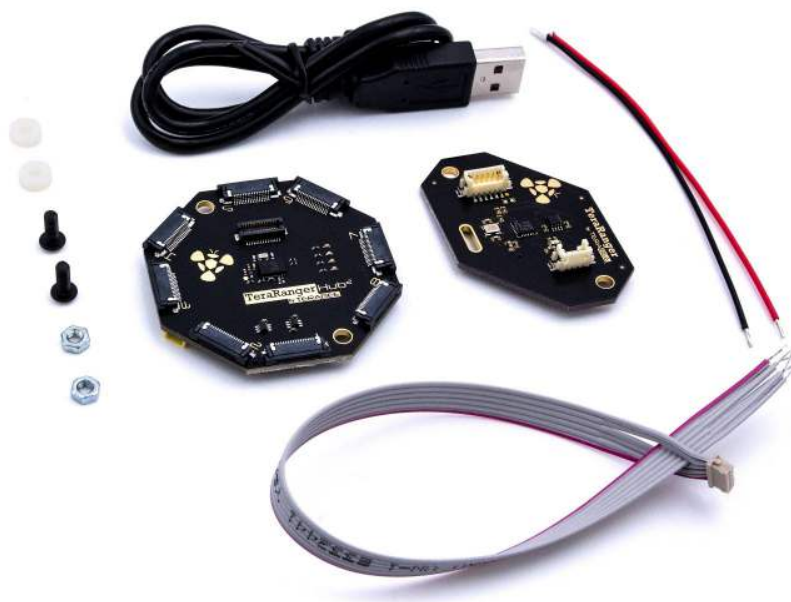

TeraRanger Hub Evo is a **compact and lightweight (13g)** board that enables you to connect up to 8 Evo sensors (Evo 60m, Evo 3m, Evo 600Hz) and stream **distance data in millimeters via USB or UART interfaces**. Readings from each sensor can be synchronized to **avoid cross-talk** making it super easy to setup ‘plug and play’ **sensor arrays!** It is the ideal solution for **selective point cloud creation and rapid prototyping** of multi-sensor configurations. In addition, an **onboard Inertial Measurement Unit (IMU)** provides data on the hub’s spatial orientation.

Hub Evo comes with a **UART board** - a clip-on accessory that enables users to stream distance readings via UART interface. The UART board also provides an interface to control an **intelligent multi-colored LED light source** when navigating close to hazards.

A **Graphical User Interface (GUI)** is available for download and provides easy visualization of sensor readings on PC for demonstrations and testing purposes. **Drivers for ROS** (Robot Operating System) are also available, adding to the plug and play convenience!

Just some of the many **use cases** for the Hub Evo include: robot navigation and collision avoidance; point cloud generation; presence, proximity and position detection; object and people counting; speed and velocity sensing.

## Technical Specifications

	TeraRanger Hub Evo	UART board (accessory)
Dimensions:	∅55mm x 9.2mm (H)	51mm x 36mm x 9mm (H)
Weight:	13g	7g
Mounting:	2 x M3 holes	2 x M3 holes
Supply voltage:	12V DC recommended	Powered by Hub Evo
Supply current:	25mA (plus consumption of each TeraRanger Evo sensor)	Powered by Hub Evo
Interfaces:	USB 2.0 Micro-B	UART, +3,3V level, 921600, 8, N, 1
		WS2812B LED serial control output
Connectors:	Micro USB	6pin Hirose DF13
	Proprietary extension connector	4pin Hirose DF13
Onboard IMU:	Bosch BN055	-
Update Rate modes:	50Hz; 100Hz; 250Hz; 500Hz; 600Hz ASAP	50Hz; 100Hz; 250Hz; 500Hz; 600Hz ASAP
Embedded Processing Unit:	ARM Cortex-M7 32-bit RISC core	-
Compatible with:	Evo 60m, Evo 3m, Evo 600Hz	TeraRanger Hub Evo

## In the box

- TeraRanger Hub Evo
- UART board
- Micro-USB cable (50cm)
- UART cable: DF13 6pin to open ended cable (22cm)
- Power cable with open ends (10cm)
- M3 screws x 2pcs
- M3, 3mm spacers x 2pcs
- M3 nuts x 2pcs



Compatible with Evo sensors

	Range	Update rate	Accuracy	FOV (per sensor)
Evo 60m	0.5m to 60m	Up to 240Hz	±4cm below 14m, 1.5% above 14m	Approx. 2°
Evo 3m	0.1m to 3m	Fixed 100Hz	±2cm	Approx. 2°
Evo 600Hz	0.75m to 8m	Fixed 600Hz	±12cm	Approx. 2°

## Dimensions

### TeraRanger Hub Evo

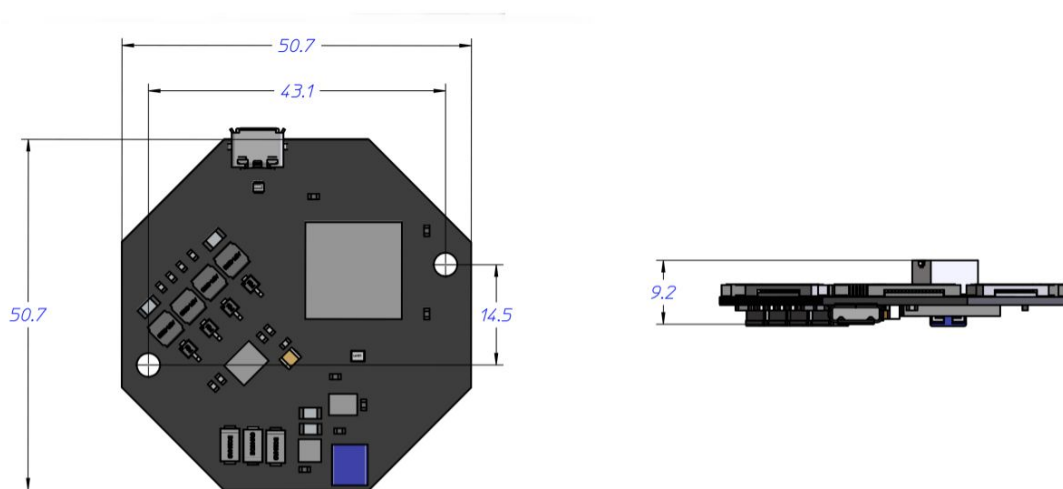

### UART board

