

LOC AF DIST 50

REVISIONS

P	LTR	DESCRIPTION	DATE FECHA	DWN DIBUJO	APVD APROBADO
	AC	REVISED PER DG3A-0609-02	11OCT2002	MF	DD
-	-	-	-	-	-

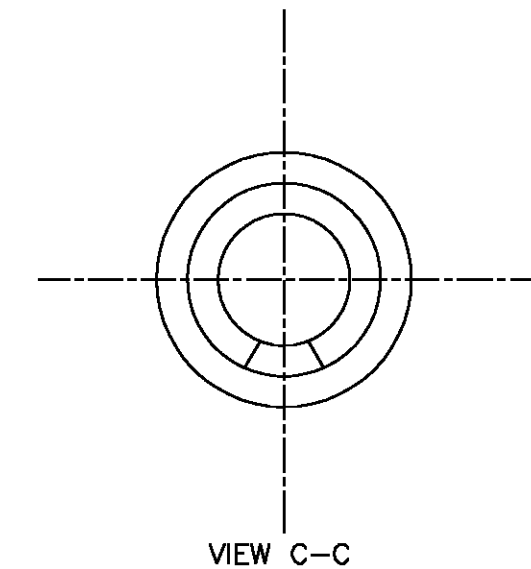
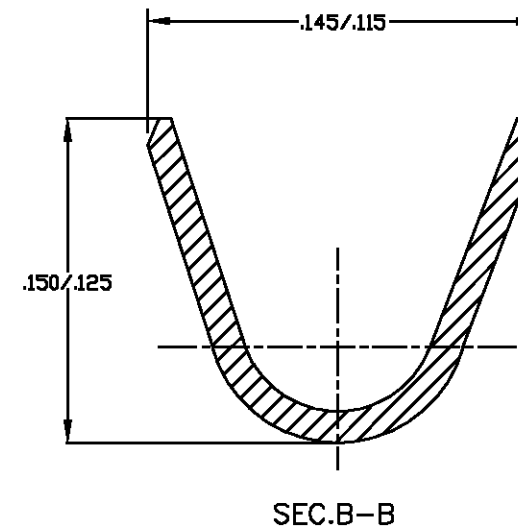
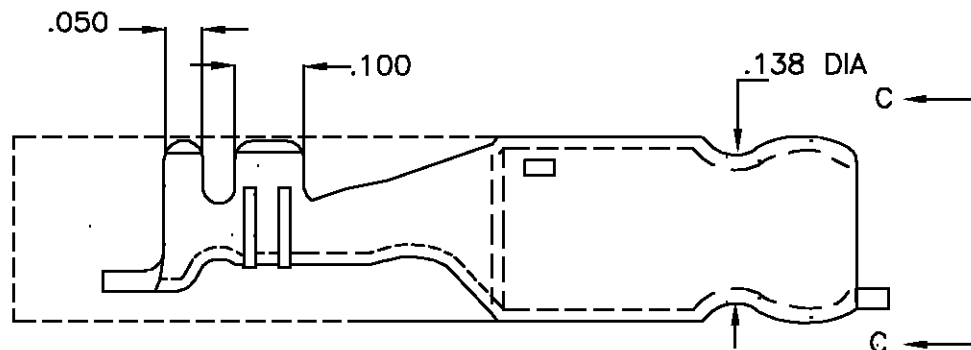
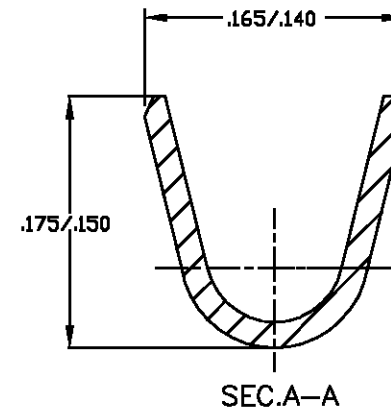
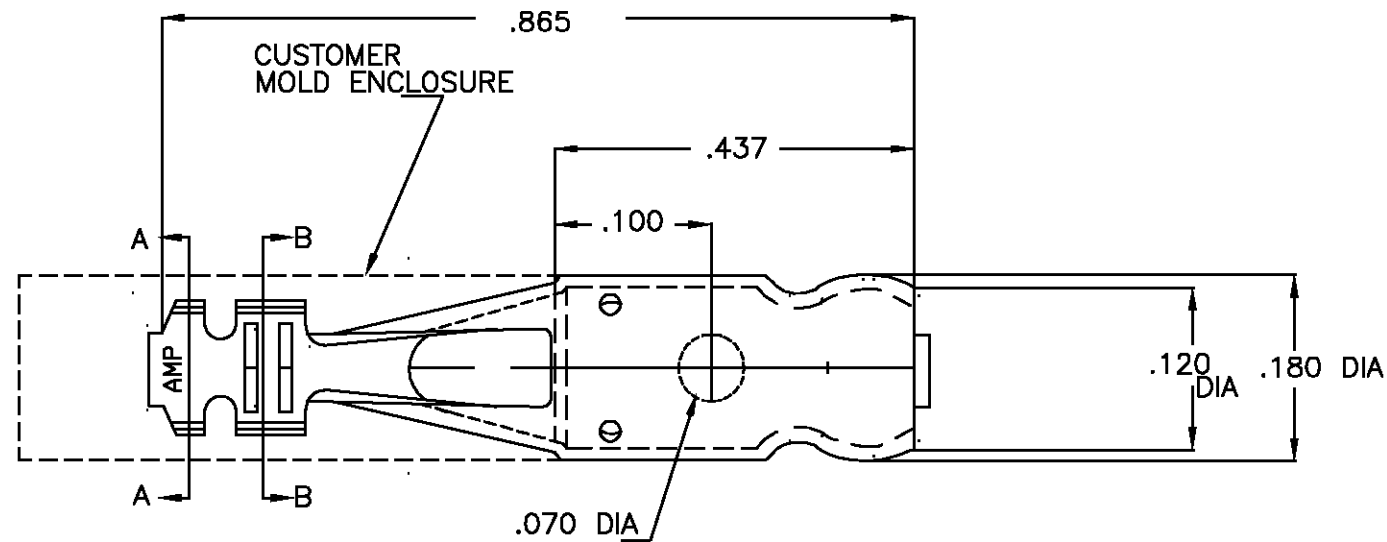

PART NUMBER	MATERIAL FINISH	REMARKS
42530-1	.018 BRASS-NONE	REVERSE REEL OF 60597-2
42530-2	.018 BRASS-TIN	STD REEL
42530-3	.018 BRASS-TIN/NI	REVERSE REEL OF 60597-4

OBSOLETE.

THIS DRAWING IS A CONTROLLED DOCUMENT FOR AMP INCORPORATED. IT IS SUBJECT TO CHANGE AND THE CONTROLLING ENGINEERING ORGANIZATION SHOULD BE CONTACTED FOR THE LATEST REVISION. ESTE PLANO ES UN DOCUMENTO CONTROLADO POR AMP INCORPORATED. ESTA SUJETO A CAMBIOS Y HAY QUE CONTACTAR AL DEPT. DE INGENIERIA POR LA ULTIMA REVISION.		DWN/DIBUJO EDUARDO VILLAR		AMP de Mexico S.A. Tlalnepantla, Mexico.	
DIMENSIONS: MEDIDAS, INCHES		CHK/CONTROLADO MAURICIO ALVARADO			
		TOLERANCES UNLESS OTHERWISE SPECIFIED: TOLERANCIAS SALVO OTRA INDICACION.		NAME NOMBRE	
		0 PLC/LUG ± 1 PLC/LUG ± 2 PLC/LUG ± ±.013 3 PLC/LUG ± 4 PLC/LUG ± ANGLES/ANGULOS ± 1°0'		PRODUCT SPEC ESPEC. DE PRODUCTO	
MATERIAL SEE TABLE		FINISH ACABADO		APPLICATION SPEC ESPEC. DE APLICACION	
		WEIGHT PESO		SIZE TAMAÑO A3	CAGE CODE CODIGO DE CELDA 00779
				DRAWING NO PLANO NO 42530	SCALE ESCALA s/e
				SHEET HOJA 1	OF 1 DE 1
				REV AC	