

PART NUMBER	REVISION	DESCRIPTION	FEED TYPE
2151957-1	B	FINE CRIMP HEIGHT ADJUST	MECHANICAL
2151957-2	B	FINE CRIMP HEIGHT ADJUST	PNEUMATIC
7-2151957-1	B	MECHANICAL AND CRIMP TOOLING KIT	MECHANICAL
7-2151957-2	B	PNEUMATIC AND CRIMP TOOLING KIT	PNEUMATIC
7-2151957-7	A	CRIMP TOOLING KIT	-

ATLANTIC VERSION TERMINATOR INTERFACE ADAPTER

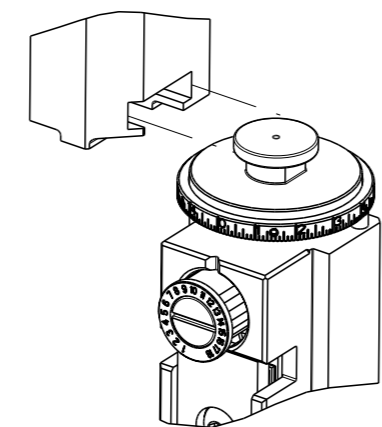

APPLICATOR DATA		
CRIMP	SIZE	TYPE
WIRE	2.70 mm [.106]	F
INSUL	3.30 mm [.130]	F

APPLICATOR INSTRUCTIONS  
408-35042

TERMINAL DATA: YAZAKI TERMINAL YAZAKI CRIMP SPECIFICATION			
TERMINAL NAME: TERMINAL, BLADE			
WIRE STRIP LENGTH	INSULATION DIAMETER RANGE		
4.00-5.00 mm [.157-.197 IN]	2.79mm MAX [.110 IN]		
TERMINAL APPLICATION SPECIFICATION	72-WT08-046		
TERMINALS APPLIED			
TE TERMINAL	YAZAKI TERMINAL	TE TERMINAL	YAZAKI TERMINAL
286816-1	7114-1231		

WIRE SIZE	CRIMP HEIGHT mm [INCH]	CRIMP HEIGHT REFERENCE SETTING
2.00mm2	1.95+/-0.05 [.077+/-0.002]	3.6
1.25mm2	1.65+/-0.05 [.065+/-0.002]	7.0
0.85mm2	1.55+/-0.05 [.061+/-0.002]	8.1

- ⚠ RECOMMENDED SPARE PARTS
- ⚠ REFER TO SUPPLIED INSTRUCTION SHEET FOR CLEANING, LUBRICATION AND STORAGE OF APPLICATOR.
- ⚠ APPLY PART NUMBER 2-23419-6 LOCTITE TO THREADS OF ITEM 242.
- ⚠ CRIMP HEIGHT REFERENCE SETTING WAS THE SETTING USED WHEN THE APPLICATOR WAS QUALIFIED AT THE FACTORY. ADJUSTMENT MAY BE NECESSARY WHEN RUNNING APPLICATOR IN THE FIELD.
- 5. UNLESS SPECIFIED OTHERWISE TORQUE VALUES SHALL BE USED PER DOCUMENT, 101-35000.

**\*WARNING**  
ON INSTALLATION, SET WIRE DISC TO CRIMP HEIGHT REFERENCE SETTING FOR LARGEST WIRE SIZE. CRIMP HEIGHT REFERENCE SETTINGS GREATER THAN THE VALUE SHOWN MAY CAUSE DAMAGE TO THE CRIMP TOOLING, REFER TO THE INSTRUCTION SHEET FOR PROPER SETUP AND ADJUSTMENTS.

**ATLANTIC VERSION**  
Shown on sheets 1 of 4 & 2 of 4  
(Pacific version shown on sheets 3 of 4 & 4 of 4)

LOC	DIST	REVISIONS					
		P	LY#	DESCRIPTION	DATE	OWN	APVD
A	66			RELEASED	03JUL2013	LG	TE
				ECR-20-011626	18AUG2020	FJ	TE

-	1	-	1	-	2119641-1	FEED CAM, AIR FEED	248	
-	1	1	1	1	2119082-8	CAM, SNAIL, INSULATION ADJUSTMENT	244	
-	1	1	1	1	2079764-1	WASHER, WAVE SPRING, CREST-TO-CREST	243	
-	1	1	1	1	2119083-1	RETAINER, INSULATION DIAL	242	
-	1	1	1	1	7-18023-7	SCR, SKT HD CAP M3 X 4.0	241	
-	-	1	-	1	2119580-1	MECHANICAL FEED ASSEMBLY	239	
-	-	-	-	-	2844940-1	AIR FEED MODULE	238	
-	REF	REF	REF	REF	994970-2	COUNTER, MAGNETIC	164	
-	1	1	1	1	1-22281-8	SPRING, COMPRESSION	121	
-	1	1	1	1	1803117-1	GUARD, FRONT CHIP	119	
-	1	1	1	1	2844908-1	SCREW, LOCKING	99	
-	1	1	1	1	2844907-1	POST, LOCKING	98	
-	1	1	1	1	2-690438-5	FRONT STRIP GUIDE	96	
-	2	2	2	2	2168083-1	SCR, SKT HD CAP, RoHS, M3 X 8.0	95	
-	1	1	1	1	2168083-6	SCR, SKT HD CAP, RoHS, M5 X 65	93	
-	1	1	1	1	455888-5	SPACER, CRIMPER	82	
-	1	1	1	1	1803607-3	DOCUMENTATION PACKAGE	71	
-	1	1	1	1	2119740-1	TAG, IDENTIFICATION	67	
-	2	2	2	2	2168078-1	SCREW, DRIVE, RH, RoHS, 2 x .188	66	
-	2	2	2	2	2-18032-5	SCR, SET, FLT PNT, M5 X 20.0	61	
-	1	1	1	1	2168083-2	SCR, SKT HD CAP, RoHS, M4 X 8.0	60	
-	1	1	1	1	5-18022-5	SCR, HEX HD CAP, M4 X 6.0	59	
-	1	1	1	1	1338685-1	PAWL, FEED	56	
-	4	4	4	4	2168083-3	SCR, SKT HD CAP, RoHS, M4 X 12.0	54	
-	2	2	2	2	2168083-8	SCR, SKT HD CAP, RoHS, M4 X 16	53	
-	1	1	1	1	5018030-1	NUT, HEX, REG, RoHS, M3	52	
-	1	1	1	1	811242-5	BUMPER, HOLD DOWN	51	
-	1	1	1	1	690753-2	SPACER, TONKER	50	
-	1	2	1	2	18023-9	SCR, SKT HD CAP M4 X 6.0	49	
-	-	1	-	1	2119652-1	FEED CAM, PRE FEED	48	
-	-	1	-	1	2119653-1	FEED CAM, POST FEED	47	
-	1	1	1	1	1803583-9	APPLICATOR BASIC ASSEMBLY, SF	46	
-	1	1	1	1	1803515-1	RAM ASSEMBLY, SF ATLANTIC	44	
-	1	1	1	1	1803602-1	SCR, BHSC, RoHS (M8 X 25)	41	
-	1	1	1	1	3-1752356-4	SUPPORT, TERMINAL	34	
-	2	2	2	2	2079383-5	SCR, BHSC, RoHS (M4 X 20)	33	
-	2	2	2	2	2-2844962-8	SPACER, CYLINDRICAL, STRIP GUIDE	30	
-	1	1	1	1	2844938-1	PLATE, STRIP GUIDE	29	
-	1	1	1	1	1-455888-0	SPACER, CRIMPER	28	
-	2	2	2	2	22283-1	SPRING, COMPRESSION	27	
-	1	1	1	1	356835-1	LEVER, DRAG RELEASE	26	
-	1	1	1	1	240792-1	DRAG, TERMINAL	25	
-	1	1	1	1	1320928-2	STRIP GUIDE	24	
-	1	1	1	1	980371-4	SCR, SKT HD SHLDR 5.0 DIA X 6.0	23	
-	1	1	1	1	2168083-2	SCR, SKT HD CAP, RoHS, M4 X 8.0	21	
-	1	1	1	1	1-18028-2	WASHER, FLAT, REG M4	20	
-	1	1	1	1	2119533-1	STRIPPER, SIDE FEED	19	
-	1	1	1	1	2119806-1	INSERT, SHEAR	13	
-	1	1	1	1	3-22280-3	SPRING, COMPRESSION	12	
-	1	1	1	1	1-356885-3	STOP, SHEAR	11	
-	1	1	1	1	2119805-1	SHEAR HOLDER, FRONT	10	
-	1	1	1	1	1803119-1	FLOATING SHEAR, FRONT	9	
-	1	2	2	1	1	2-1633928-3	ANVIL, COMBINATION	8
-	1	1	1	1	1	1-240641-0	SPACER	7
-	-	-	-	-	-	-	6	
-	1	1	1	1	2119757-8	DEPRESSOR, SHEAR	5	
-	1	1	1	1	1-238011-7	BLOCK, CRIMPER SPACER	4	
-	1	2	2	1	1	1-1633961-5	CRIMPER, INSULATION F PREMIUM	3
-	1	1	1	1	455888-7	SPACER, CRIMPER	2	
-	1	2	2	1	1	5-1633609-6	CRIMPER, WIRE	1
-	77	72	71	-2	-1	PART NO	ITEM NO	

DIMENSIONS:		TOLERANCES UNLESS OTHERWISE SPECIFIED:		OWN		NAME			
mm	0 PLC ±	1 PLC ±	2 PLC ±	3 PLC ±	4 PLC ±	ANGLES ±	FINISH ±		
	MATERIAL		WEIGHT		SCALE		SHEET		
				A1		00779		C=2151957	
				Customer Accessible Production Drawing		SCALE 1:2		SHEET 1 of 4	

LOC	DIST	REVISIONS			
		REV	DATE	BY	APPV
A	66	-	SEE SHEET 1	-	-

# FEED TYPE MECHANICAL

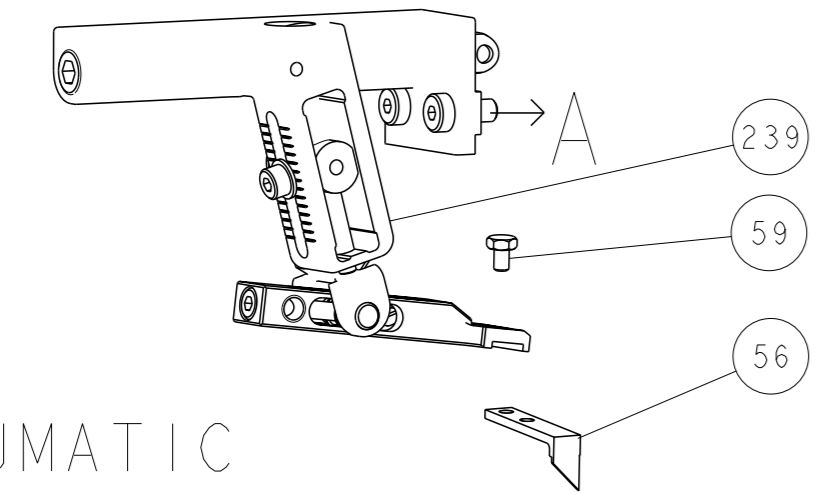

## PNEUMATIC

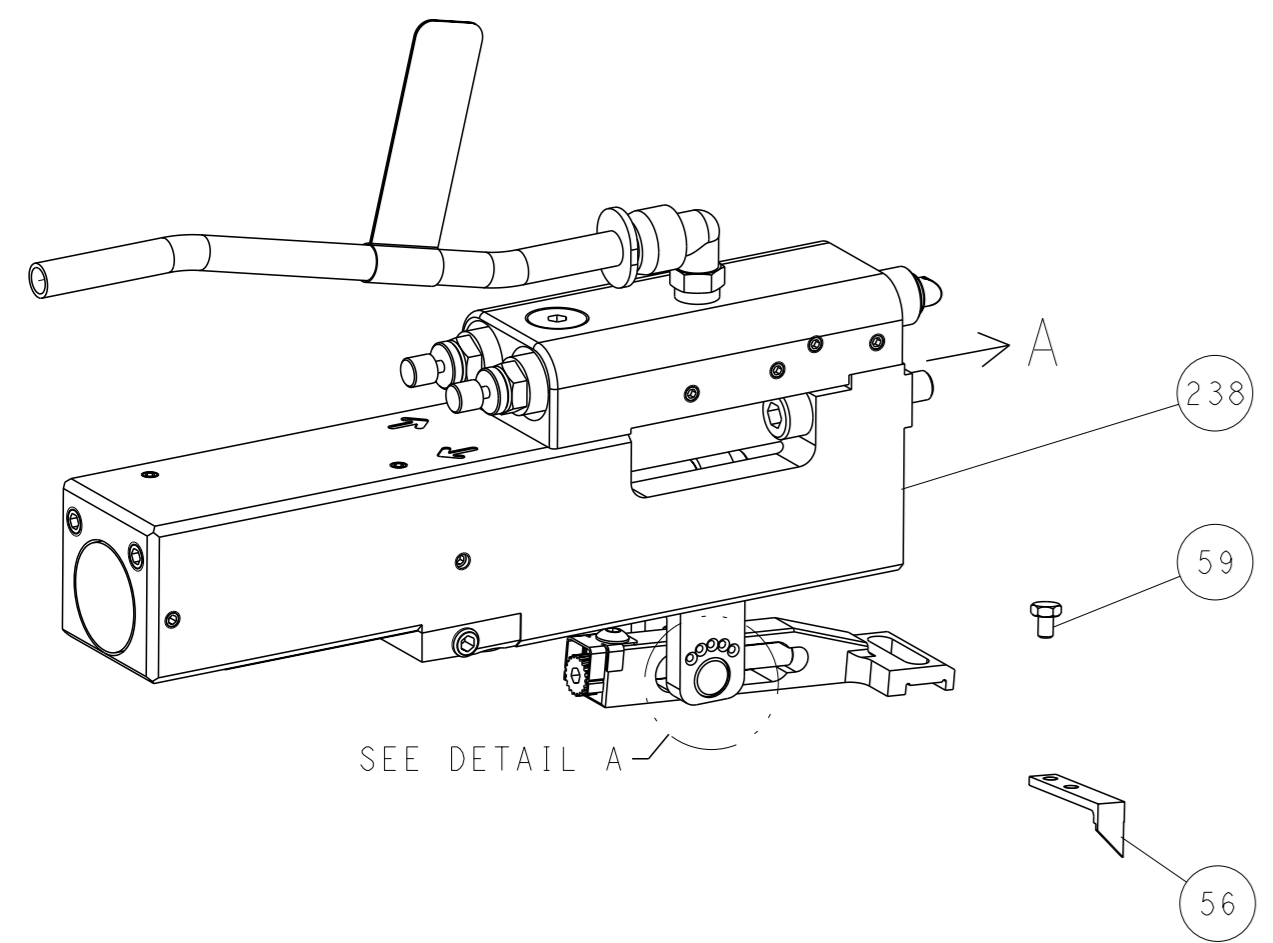

## FEED SPRING SETTING POSITION (SHOWN FROM REAR SIDE)

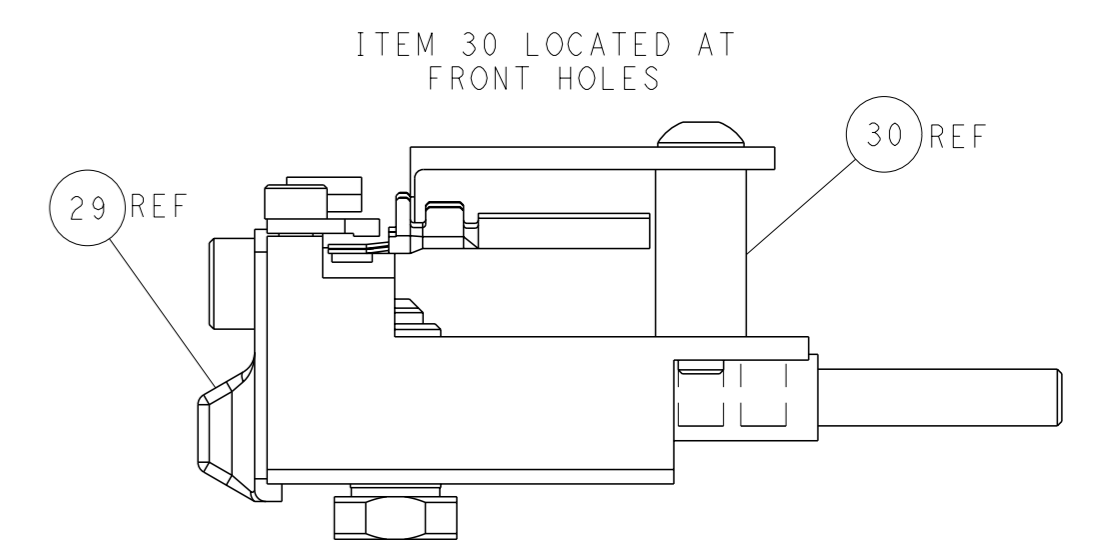
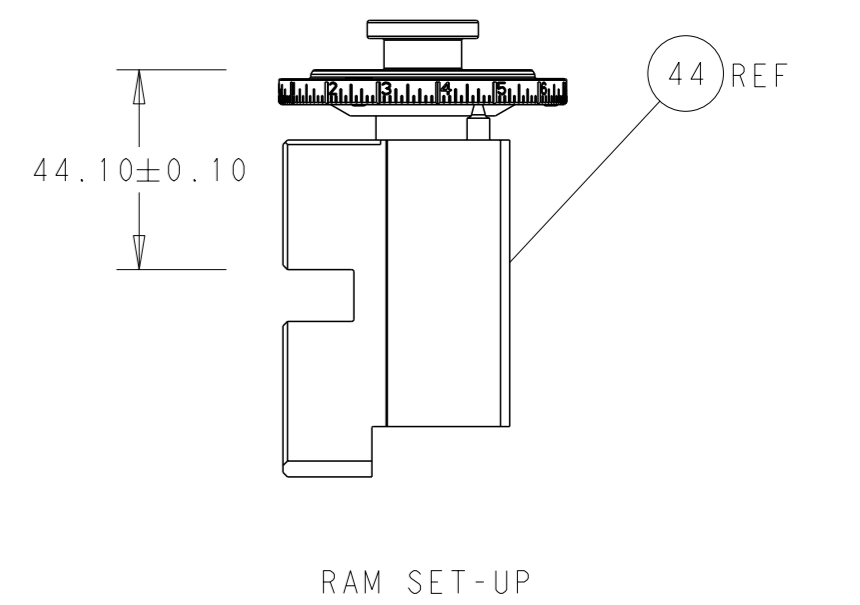
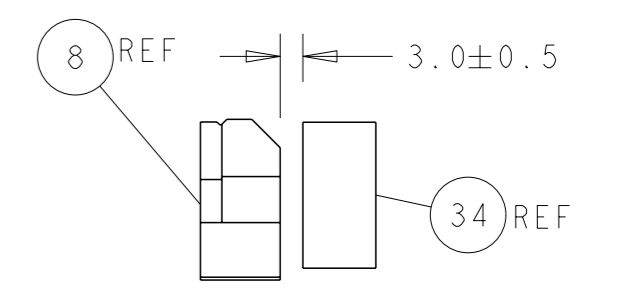
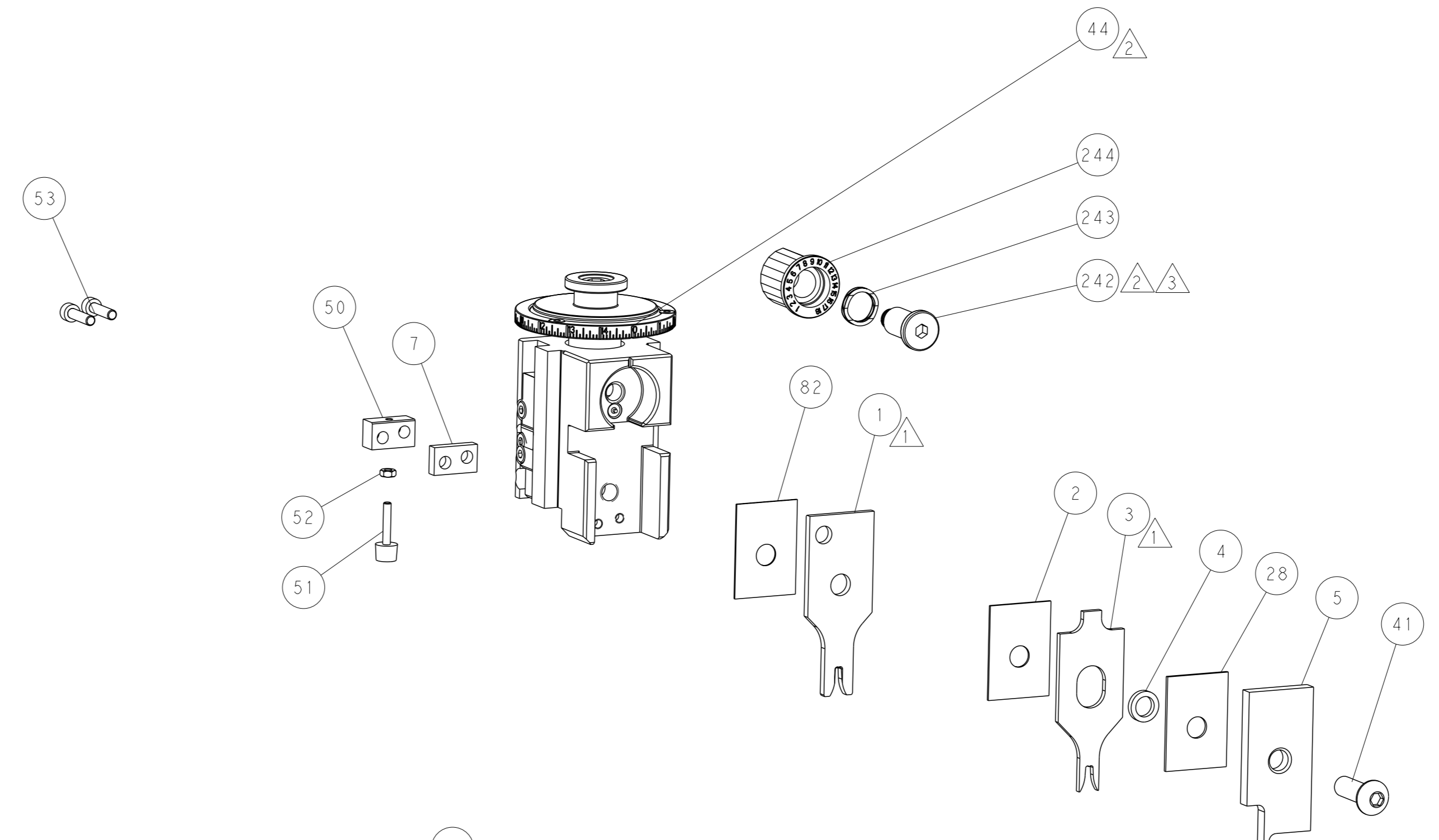
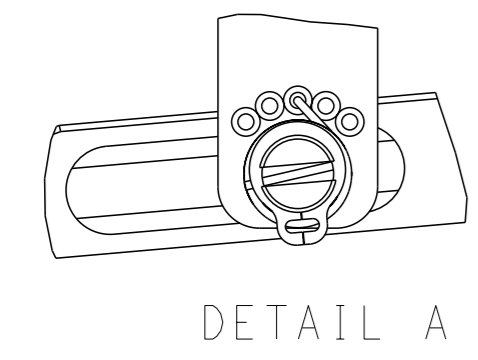

# CAM POSITIONS

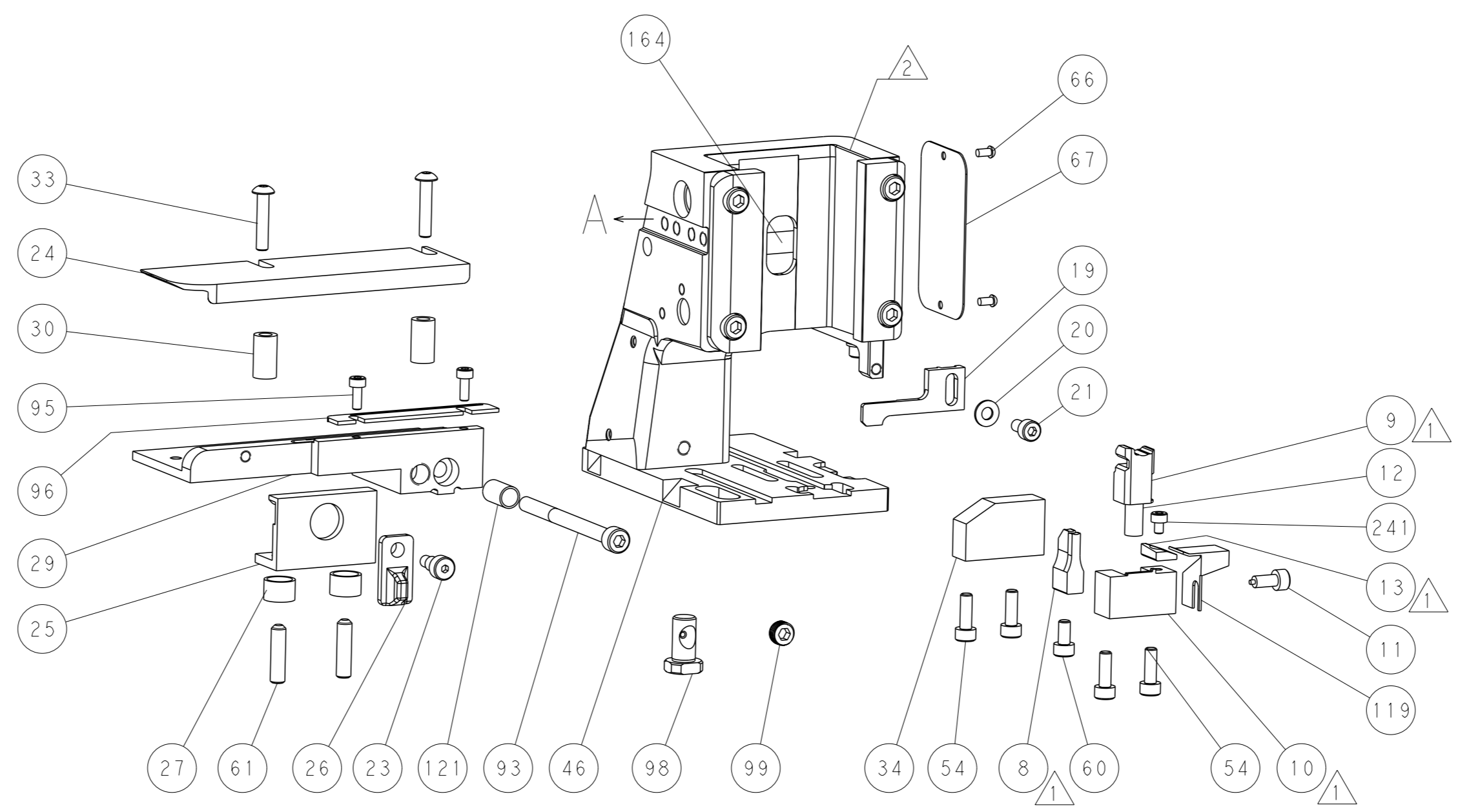
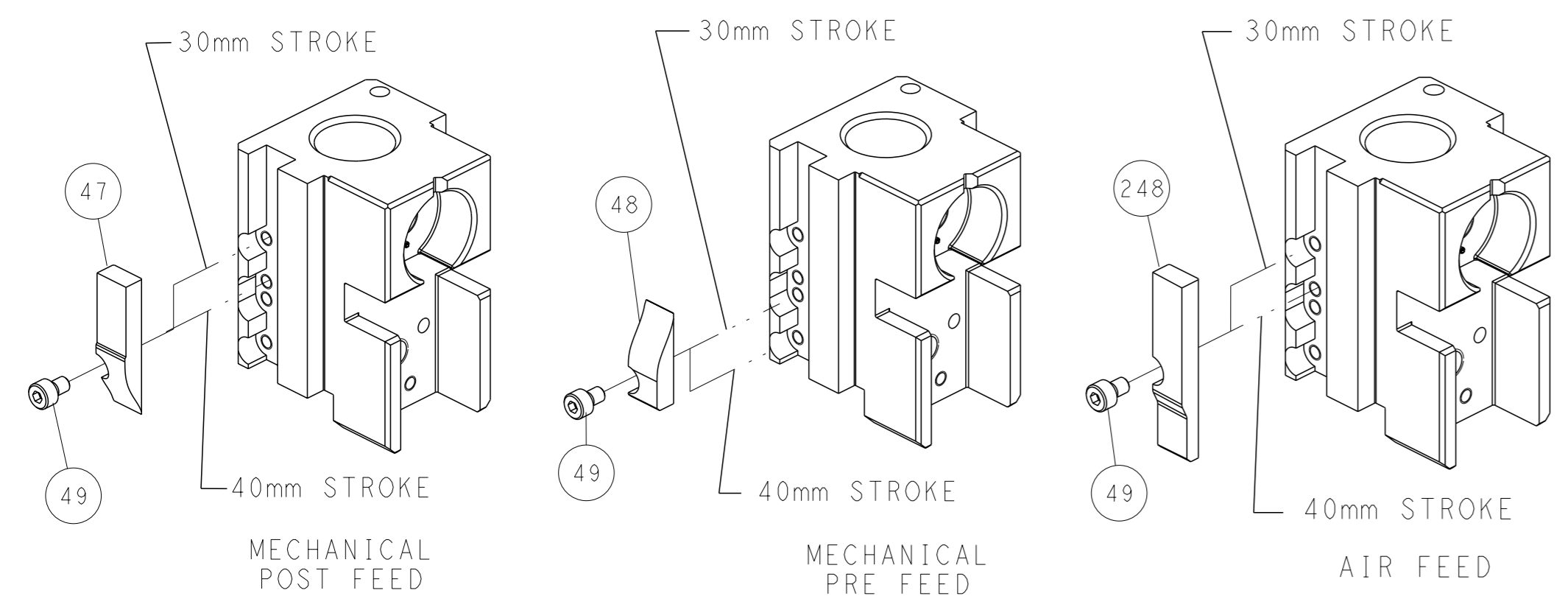

**ATLANTIC VERSION**  
 Shown on sheets 1 of 4 & 2 of 4  
 (Pacific version shown on sheets 3 of 4 & 4 of 4)

<small>THIS DRAWING IS A CONTROLLED DOCUMENT FOR TYCO ELECTRONICS CORPORATION. IT IS SUBJECT TO CHANGE AND THE CONTROL AND RESTRICTION DESIGNATION SHOULD BE CONTACTED FOR THE LATEST REVISION.</small>		DWN: R. HUANG 24MAY2013 CHK: L. ZHANG 24MAY2013 APVD: J. GUO 24MAY2013	NAME: Ocean Side Feed Applicator SIZE: A1 CAGE CODE: 00779 DRAWING NO: 2151957	TE Connectivity Harrisburg, PA 17105-3608
DIMENSIONS: mm TOLERANCES UNLESS OTHERWISE SPECIFIED: 0 PLC ± 1 PLC ± 2 PLC ± 3 PLC ± 4 PLC ± ANGLES FINISH ±	WEIGHT: - SCALE: 1:2 SHEET: 2 of 4 REV: B	RESTRICTED TO: -	Customer Accessible Production Drawing	

PART NUMBER	REVISION	DESCRIPTION	FEED TYPE
2-2151957-1	B	FINE CRIMP HEIGHT ADJUST	MECHANICAL
2-2151957-2	B	FINE CRIMP HEIGHT ADJUST	PNEUMATIC
7-2151957-7	A	CRIMP TOOLING KIT	-

PACIFIC VERSION TERMINATOR  
INTERFACE ADAPTER

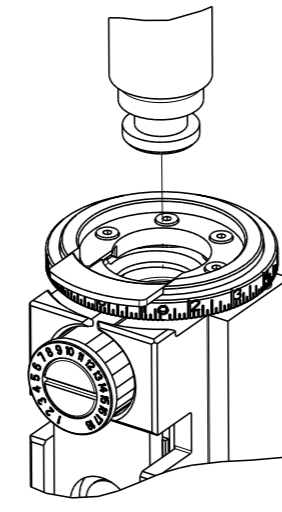

APPLICATOR DATA		
CRIMP	SIZE	TYPE
WIRE	2.70 mm [.106]	F
INSUL	3.30 mm [.130]	F
APPLICATOR INSTRUCTIONS 408-35042		

TERMINAL DATA: YAZAKI TERMINAL YAZAKI CRIMP SPECIFICATION			
TERMINAL NAME: TERMINAL, BLADE			
WIRE STRIP LENGTH 4.00-5.00 mm [.157-.197 IN]		INSULATION DIAMETER RANGE Ø 2.79mm MAX [.110 IN]	
TERMINAL APPLICATION SPECIFICATION 72-WT08-046			
TERMINALS APPLIED			
TE TERMINAL	YAZAKI TERMINAL	TE TERMINAL	YAZAKI TERMINAL
286816-1	7114-1231		

WIRE SIZE	CRIMP HEIGHT mm [INCH]	CRIMP HEIGHT REFERENCE SETTING
2.00mm2	1.95 +/- 0.05 [.077 +/- .002]	3.6
1.25mm2	1.65 +/- 0.05 [.065 +/- .002]	7.0
0.85mm2	1.55 +/- 0.05 [.061 +/- .002]	8.1

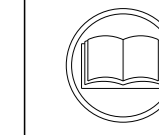

- RECOMMENDED SPARE PARTS
- REFER TO SUPPLIED INSTRUCTION SHEET FOR CLEANING, LUBRICATION AND STORAGE OF APPLICATOR.
- APPLY PART NUMBER 2-23419-6 LOCTITE TO THREADS OF ITEM 242.
- CRIMP HEIGHT REFERENCE SETTING WAS THE SETTING USED WHEN THE APPLICATOR WAS QUALIFIED AT THE FACTORY. ADJUSTMENT MAY BE NECESSARY WHEN RUNNING APPLICATOR IN THE FIELD.
- UNLESS SPECIFIED OTHERWISE TORQUE VALUES SHALL BE USED PER DOCUMENT, 101-35000.

**\*WARNING**  
ON INSTALLATION, SET WIRE DISC TO CRIMP HEIGHT REFERENCE SETTING FOR LARGEST WIRE SIZE. CRIMP HEIGHT REFERENCE SETTINGS GREATER THAN THE VALUE SHOWN MAY CAUSE DAMAGE TO THE CRIMP TOOLING, REFER TO THE INSTRUCTION SHEET FOR PROPER SETUP AND ADJUSTMENTS.

LOC	DIST	REVISIONS					
A	66	P	LYR	DESCRIPTION	DATE	OWN	APVD
		-	-	SEE SHEET 1	-	-	-

-	1	1	2119082-8	CAM, SNAIL, INSULATION ADJUSTMENT	244
-	1	1	2079764-1	WASHER, WAVE SPRING, CREST-TO-CREST	243
3	-	1	2119083-1	RETAINER, INSULATION DIAL	242
-	1	1	7-18023-7	SCR, SKT HD CAP M3 X 4.0	241
-	-	1	2119580-1	MECHANICAL FEED ASSEMBLY	239
-	1	-	2844940-1	AIR FEED MODULE	238
-	REF	REF	994970-2	COUNTER, MAGNETIC	164
-	1	-	2119641-2	FEED CAM, AIR FEED	151
-	1	1	2168083-8	SCR, SKT HD CAP, RoHS, M4 X 16	144
-	4	4	2168083-9	SCR, SKT HD CAP, RoHS, M4 X 20	143
-	-	1	2119653-2	FEED CAM, POST FEED	142
-	1	1	1-1803583-0	APPLICATOR BASIC ASSEMBLY, SF	141
-	1	1	1803516-1	RAM ASSEMBLY, SF PACIFIC	140
-	1	1	1-22281-8	SPRING, COMPRESSION	121
-	1	1	1803117-1	GUARD, FRONT CHIP	119
-	1	1	2844908-1	SCREW, LOCKING	99
-	1	1	2844907-1	POST, LOCKING	98
-	1	1	2-690438-5	FRONT STRIP GUIDE	96
-	2	2	2168083-1	SCR, SKT HD CAP, RoHS, M3 X 8.0	95
-	1	1	2168083-6	SCR, SKT HD CAP, RoHS, M5 X 65	93
-	1	1	455888-5	SPACER, CRIMPER	82
-	1	1	1803607-3	DOCUMENTATION PACKAGE	71
-	1	1	2119740-1	TAG, IDENTIFICATION	67
-	2	2	2168078-1	SCREW, DRIVE, RH, RoHS, 2 x .188	66
-	2	2	2-18032-5	SCR, SET, FLT PNT, M5 X 20.0	61
-	1	1	5-18022-5	SCR, HEX HD CAP, M4 X 6.0	59
-	1	1	1338685-1	PAWL, FEED	56
-	2	2	2168083-8	SCR, SKT HD CAP, RoHS, M4 X 16	53
-	1	1	5018030-1	NUT, HEX, REG, RoHS, M3	52
-	1	1	811242-5	BUMPER, HOLD DOWN	51
-	1	1	690753-2	SPACER, TONKER	50
-	1	2	18023-9	SCR, SKT HD CAP M4 X 6.0	49
-	-	1	2119652-1	FEED CAM, PRE FEED	48
-	1	1	1803602-1	SCR, BHSC, RoHS (M8 X 25)	41
-	1	1	3-1752356-4	SUPPORT, TERMINAL	34
-	2	2	2079383-5	SCR, BHSC, RoHS (M4 X 20)	33
-	2	2	2-2844962-8	SPACER, CYLINDRICAL, STRIP GUIDE	30
-	1	1	2844938-1	PLATE, STRIP GUIDE	29
-	1	1	1-455888-0	SPACER, CRIMPER	28
-	2	2	22283-1	SPRING, COMPRESSION	27
-	1	1	356835-1	LEVER, DRAG RELEASE	26
-	1	1	240792-1	DRAG, TERMINAL	25
-	1	1	1320928-2	STRIP GUIDE	24
-	1	1	980371-4	SCR, SKT HD SHLDR 5.0 DIA X 6.0	23
-	1	1	2168083-2	SCR, SKT HD CAP, RoHS, M4 X 8.0	21
-	1	1	1-18028-2	WASHER, FLAT, REG M4	20
-	1	1	2119533-1	STRIPPER, SIDE FEED	19
-	1	1	2119806-1	INSERT, SHEAR	13
-	1	1	3-22280-3	SPRING, COMPRESSION	12
-	1	1	1-356885-3	STOP, SHEAR	11
-	1	1	2119805-1	SHEAR HOLDER, FRONT	10
-	1	1	1803119-1	FLOATING SHEAR, FRONT	9
1	1	1	2-1633928-3	ANVIL, COMBINATION	8
-	1	1	1-240641-0	SPACER	7
-	-	-	-	-	6
-	1	1	2119757-8	DEPRESSOR, SHEAR	5
-	1	1	1-238011-7	BLOCK, CRIMPER SPACER	4
1	1	1	1-1633961-5	CRIMPER, INSULATION F PREMIUM	3
-	1	1	455888-7	SPACER, CRIMPER	2
1	1	1	5-1633609-6	CRIMPER, WIRE	1



PACIFIC VERSION  
Shown on sheets 3 of 4 & 4 of 4  
(Atlantic version shown on sheets 1 of 4 & 2 of 4)

THE DRAWING IS CONTROLLED DOCUMENT FOR THE PRODUCT. ANY CHANGES TO THE DRAWING MUST BE APPROVED BY THE DESIGN ENGINEER AND THE PRODUCT MANAGER. THIS DRAWING IS NOT TO BE USED FOR PRODUCTION UNLESS IT IS THE LATEST REVISION.		OWN: H. HUANG 24MAY2013	TE Connectivity Harrisburg, PA 17105-3608	
DIMENSIONS: mm		CHK: L. ZHANG 24MAY2013	NAME: Ocean Side Feed Applicator	
TOLERANCES UNLESS OTHERWISE SPECIFIED:		APVD: H. GUO 24MAY2013	SIZE: A1	
0 PLC ±		PRODUCT SPEC	CAGE CODE: 00779	
1 PLC ±		APPLICATION SPEC	DRAWING NO: 2151957	
2 PLC ±		RESTRICTED TO	SCALE: 1:2	
3 PLC ±		WEIGHT	SHEET 3 of 4	
4 PLC ±		Customer Accessible Production Drawing	REV B	
ANGLES FINISH		Customer Accessible Production Drawing		

LOC		DIST		REVISIONS			
A	66	P	LYR	DESCRIPTION	DATE	OWN	APVD
		-		SEE SHEET 1			

# FEED TYPE MECHANICAL

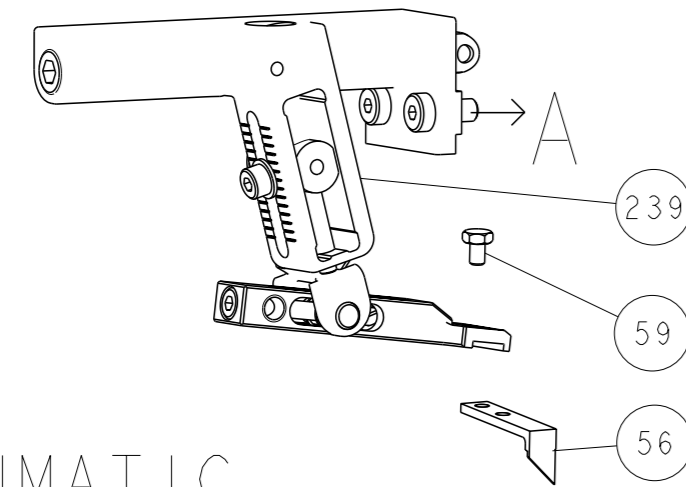

## PNEUMATIC

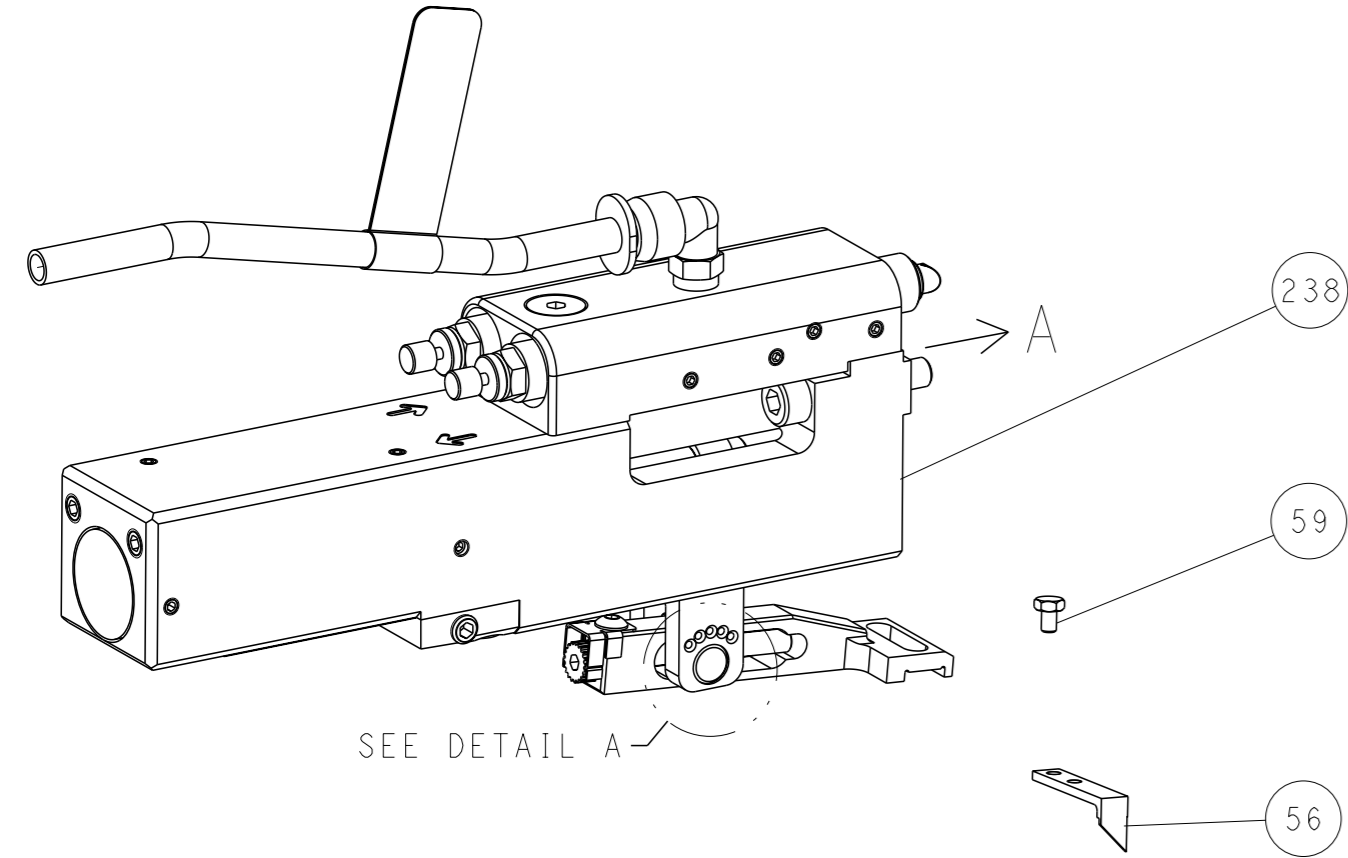

## FEED SPRING SETTING POSITION (SHOWN FROM REAR SIDE)

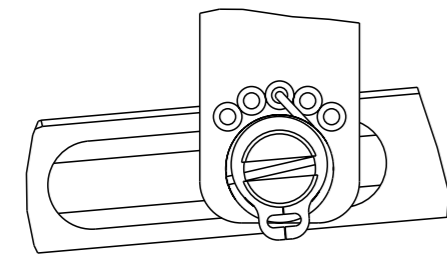

DETAIL A

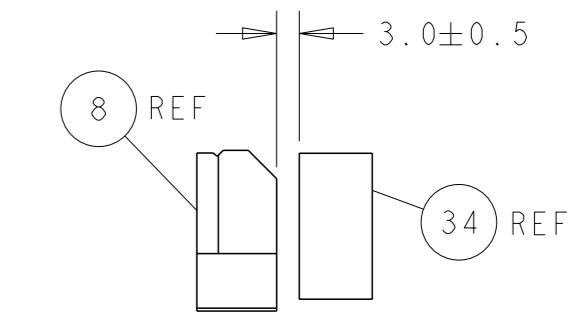
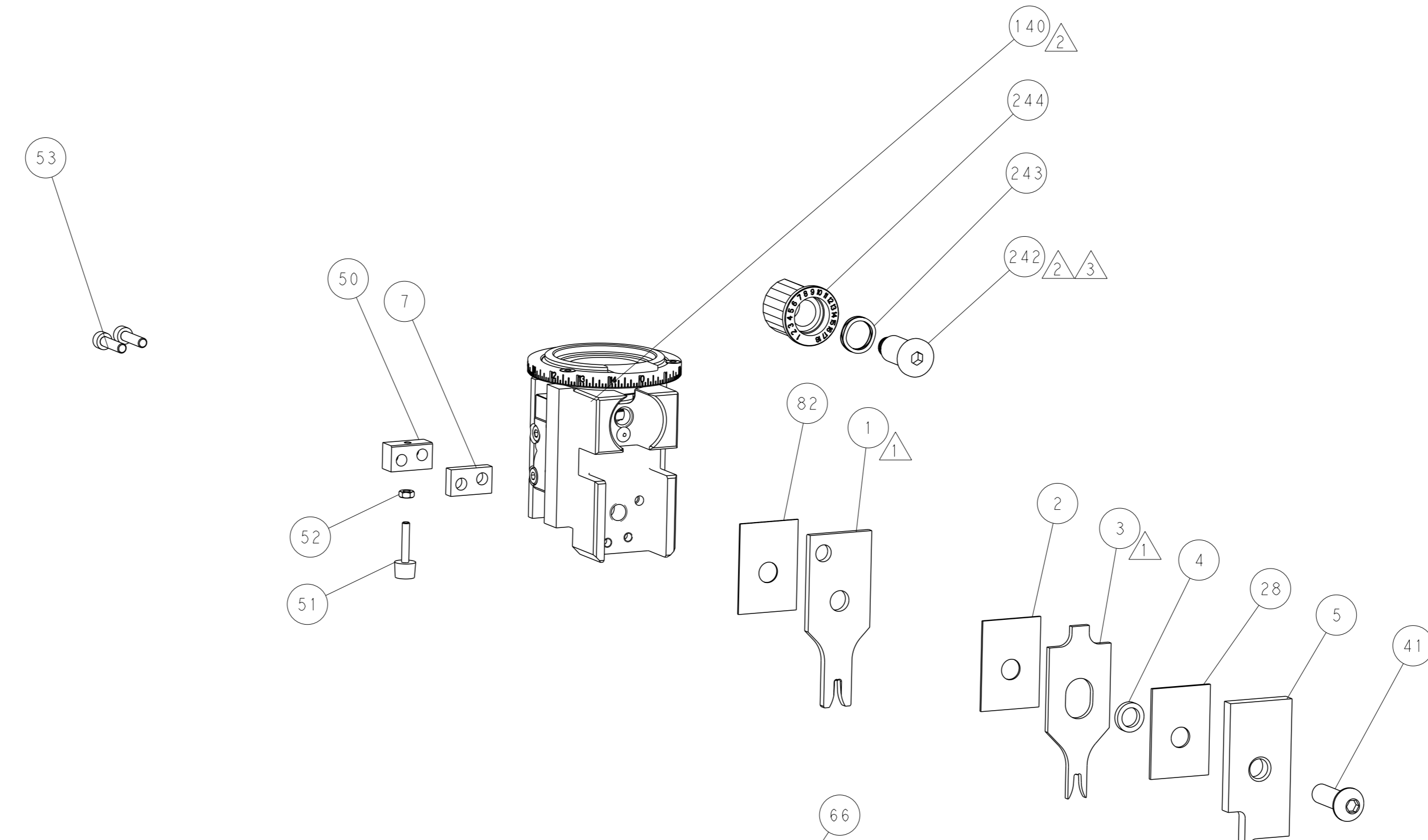

TERMINAL SUPPORT LOCATION

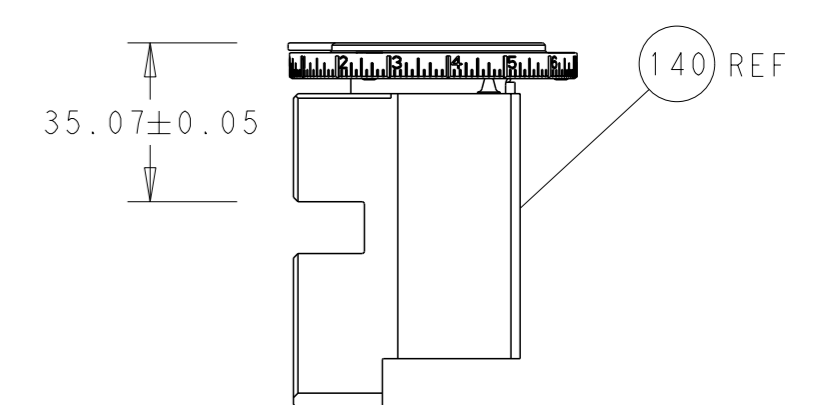

RAM SET-UP

# CAM POSITIONS

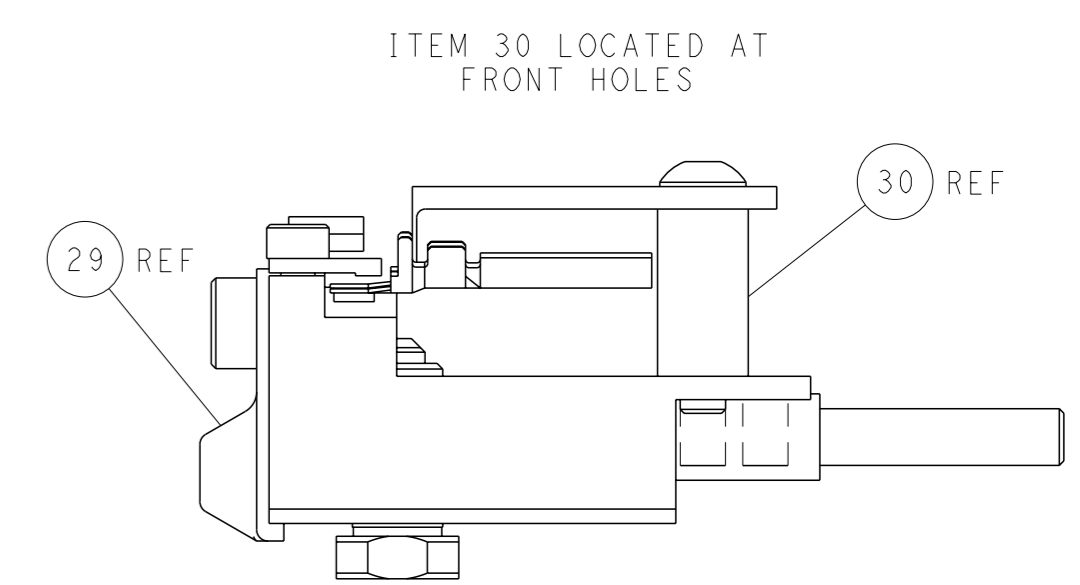
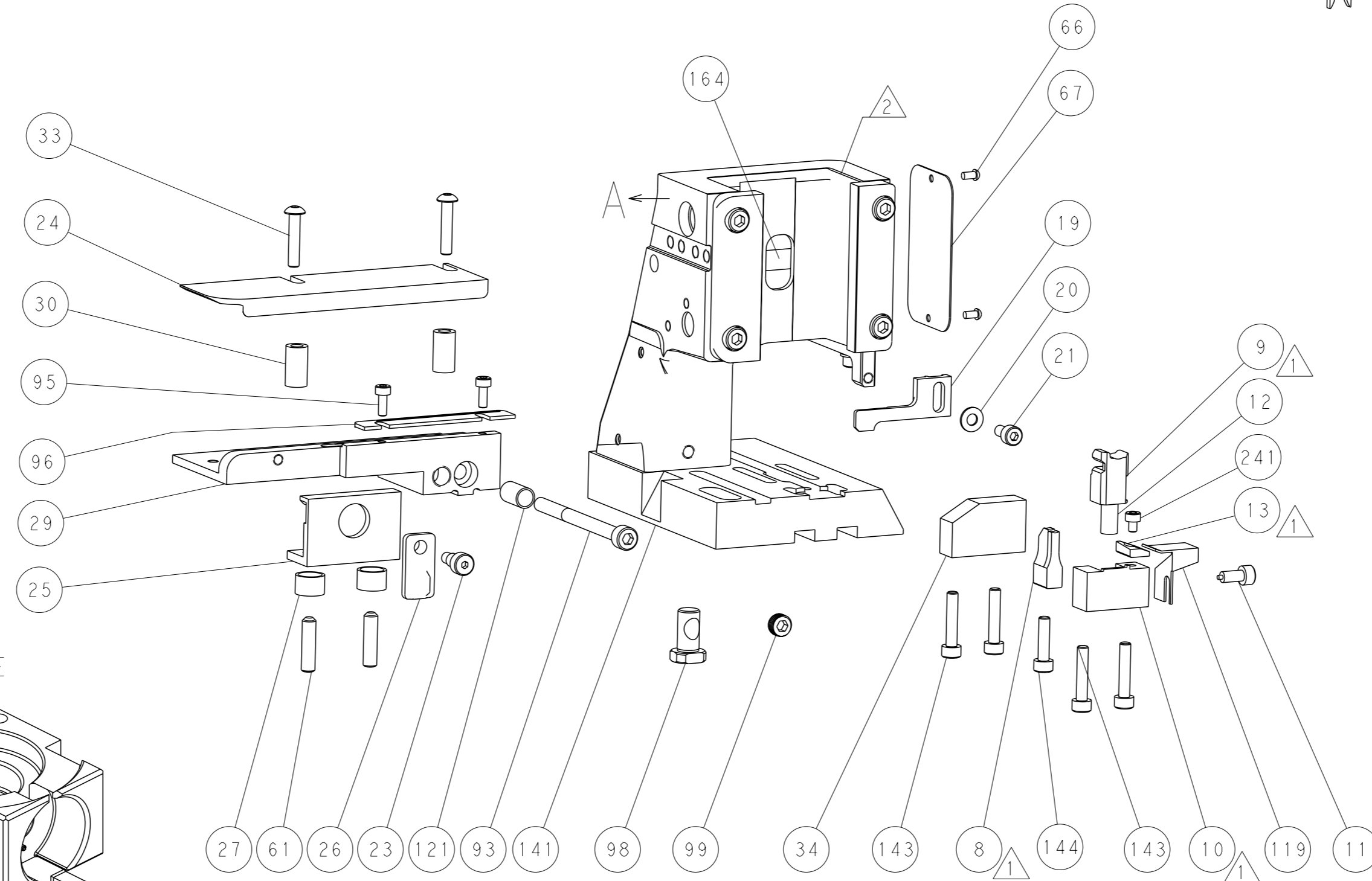
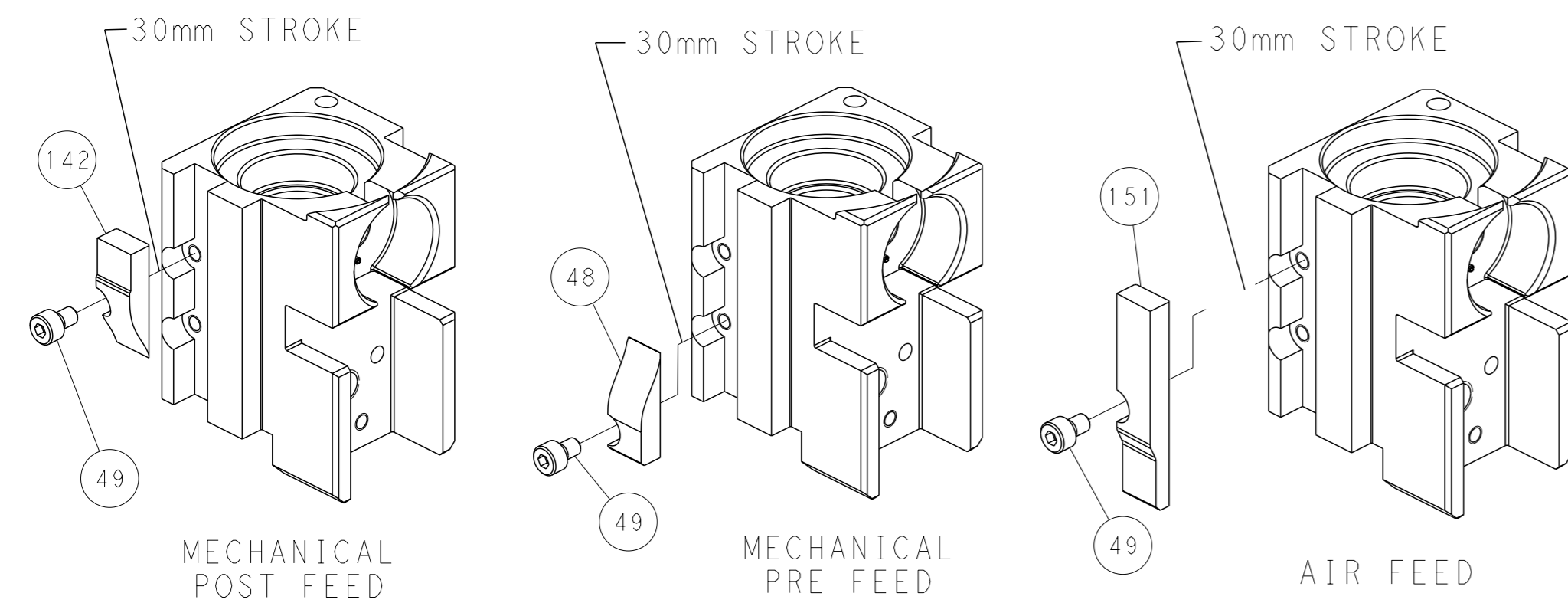

FEED TRACK POSITION GUIDE BY INSULATION BARREL

**PACIFIC VERSION**  
 Shown on sheets 3 of 4 & 4 of 4  
 (Atlantic version shown on sheets 1 of 4 & 2 of 4)

<small>THIS DRAWING IS A CONTROLLED DOCUMENT FOR TYCO ELECTRONICS CORPORATION. IT IS SUBJECT TO CHANGE AND THE USER'S RESPONSIBILITY TO OBTAIN THE LATEST REVISION SHOULD BE CONTACTED FOR THE LATEST REVISION.</small>		DWN: H. HUANG CHK: L. ZHANG APVD: J. GUO	DATE: 24MAY2013 DATE: 24MAY2013 DATE: 24MAY2013	NAME: TE Connectivity Harrisburg, PA 17105-3608
DIMENSIONS: mm TOLERANCES UNLESS OTHERWISE SPECIFIED: 0 PLC ± 1 PLC ± 2 PLC ± 3 PLC ± 4 PLC ± ANGLES FINISH *	MATERIAL:	WEIGHT:	SIZE: A1 CAGE CODE: 00779 DRAWING NO: C=2151957	RESTRICTED TO:
Customer Accessible Production Drawing		SCALE: 1:2	SHEET 4 of 4	REV B