



**MPLAB[®] Starter Kit for
PIC24H Microcontrollers
User's Guide**

Note the following details of the code protection feature on Microchip devices:

- Microchip products meet the specification contained in their particular Microchip Data Sheet.
- Microchip believes that its family of products is one of the most secure families of its kind on the market today, when used in the intended manner and under normal conditions.
- There are dishonest and possibly illegal methods used to breach the code protection feature. All of these methods, to our knowledge, require using the Microchip products in a manner outside the operating specifications contained in Microchip's Data Sheets. Most likely, the person doing so is engaged in theft of intellectual property.
- Microchip is willing to work with the customer who is concerned about the integrity of their code.
- Neither Microchip nor any other semiconductor manufacturer can guarantee the security of their code. Code protection does not mean that we are guaranteeing the product as "unbreakable."

Code protection is constantly evolving. We at Microchip are committed to continuously improving the code protection features of our products. Attempts to break Microchip's code protection feature may be a violation of the Digital Millennium Copyright Act. If such acts allow unauthorized access to your software or other copyrighted work, you may have a right to sue for relief under that Act.

Information contained in this publication regarding device applications and the like is provided only for your convenience and may be superseded by updates. It is your responsibility to ensure that your application meets with your specifications. MICROCHIP MAKES NO REPRESENTATIONS OR WARRANTIES OF ANY KIND WHETHER EXPRESS OR IMPLIED, WRITTEN OR ORAL, STATUTORY OR OTHERWISE, RELATED TO THE INFORMATION, INCLUDING BUT NOT LIMITED TO ITS CONDITION, QUALITY, PERFORMANCE, MERCHANTABILITY OR FITNESS FOR PURPOSE. Microchip disclaims all liability arising from this information and its use. Use of Microchip devices in life support and/or safety applications is entirely at the buyer's risk, and the buyer agrees to defend, indemnify and hold harmless Microchip from any and all damages, claims, suits, or expenses resulting from such use. No licenses are conveyed, implicitly or otherwise, under any Microchip intellectual property rights.

Trademarks

The Microchip name and logo, the Microchip logo, Accuron, dsPIC, KEELOQ, KEELOQ logo, MPLAB, PIC, PICmicro, PICSTART, rPIC, SmartShunt and UNI/O are registered trademarks of Microchip Technology Incorporated in the U.S.A. and other countries.

FilterLab, Linear Active Thermistor, MXDEV, MXLAB, SEEVAL, SmartSensor and The Embedded Control Solutions Company are registered trademarks of Microchip Technology Incorporated in the U.S.A.

Analog-for-the-Digital Age, Application Maestro, CodeGuard, dsPICDEM, dsPICDEM.net, dsPICworks, dsSPEAK, ECAN, ECONOMONITOR, FanSense, In-Circuit Serial Programming, ICSP, ICEPIC, Mindi, MiWi, MPASM, MPLAB Certified logo, MPLIB, MPLINK, mTouch, PICkit, PICDEM, PICDEM.net, PICtail, PIC³² logo, PowerCal, PowerInfo, PowerMate, PowerTool, REAL ICE, rLAB, Select Mode, Total Endurance, WiperLock and ZENA are trademarks of Microchip Technology Incorporated in the U.S.A. and other countries.

SQTP is a service mark of Microchip Technology Incorporated in the U.S.A.

All other trademarks mentioned herein are property of their respective companies.

© 2008, Microchip Technology Incorporated, Printed in the U.S.A., All Rights Reserved.

 Printed on recycled paper.

QUALITY MANAGEMENT SYSTEM
CERTIFIED BY DNV
== ISO/TS 16949:2002 ==

Microchip received ISO/TS-16949:2002 certification for its worldwide headquarters, design and wafer fabrication facilities in Chandler and Tempe, Arizona; Gresham, Oregon and design centers in California and India. The Company's quality system processes and procedures are for its PIC[®] MCUs and dsPIC[®] DSCs, KEELOQ[®] code hopping devices, Serial EEPROMs, microperipherals, nonvolatile memory and analog products. In addition, Microchip's quality system for the design and manufacture of development systems is ISO 9001:2000 certified.



MPLAB® STARTER KIT FOR PIC24H MICROCONTROLLERS USER'S GUIDE

Table of Contents

Preface	1
Chapter 1. Introduction	
1.1 Overview	7
1.2 Operational Requirements	8
1.3 Board Setup	8
Chapter 2. Starter Kit Demo	
2.1 Running the Demo	9
2.2 Understanding the Demo	14
2.3 Other Demo Code Examples	15
Chapter 3. Develop an Application	
3.1 Installing the Hardware and Software	17
3.2 Setting Up an Example Application for Debug	18
3.3 Running the Example Application	19
3.4 Debugging the Example Application	19
3.5 Programming the Debugged Application	22
3.6 Creating Other PIC24H MCU Applications	22
3.7 Determining Device Support and Reserved Resources	22
3.8 Troubleshooting	23
3.9 Settings Dialog, Info Tab	23
Chapter 4. Hardware	
4.1 Application Functional Overview	25
4.2 Debug Functional Overview	28
4.3 Board Components	29
Appendix A. Schematics	
A.1 Application Schematics	34
A.2 Debug Schematics	37
Index	39
Worldwide Sales and Service	40

NOTES:



MPLAB® STARTER KIT FOR PIC24H MICROCONTROLLERS USER'S GUIDE

Preface

NOTICE TO CUSTOMERS

All documentation becomes dated, and this manual is no exception. Microchip tools and documentation are constantly evolving to meet customer needs, so some actual dialogs and/or tool descriptions may differ from those in this document. Please refer to our web site (www.microchip.com) to obtain the latest documentation available.

Documents are identified with a “DS” number. This number is located on the bottom of each page, in front of the page number. The numbering convention for the DS number is “DSXXXXA”, where “XXXX” is the document number and “A” is the revision level of the document.

For the most up-to-date information on development tools, see the MPLAB® IDE online help. Select the Help menu, and then Topics to open a list of available online help files.

INTRODUCTION

This chapter contains general information that will be useful to know before you use the MPLAB® Starter Kit for PIC24H Microcontrollers (MCUs). Items discussed in this chapter include:

- Document Layout
- Conventions Used in this Guide
- Warranty Registration
- Recommended Reading
- The Microchip Web Site
- Development Systems Customer Change Notification Service
- Customer Support
- Document Revision History

DOCUMENT LAYOUT

This document describes how to use the starter kit as a development and demonstrative tool for PIC24H MCU device's processing capabilities. The manual layout is as follows:

- **Chapter 1. Introduction** – This chapter introduces the starter kit and provides an overview of its features.
- **Chapter 2. Starter Kit Demo** – This chapter describes how to use the starter kit demo software.
- **Chapter 3. Develop an Application** – This chapter describes how to debug application software on the starter kit using MPLAB® IDE.
- **Chapter 4. Hardware** – This chapter provides a functional overview of the starter kit and identifies the major hardware components.
- **Appendix A. Schematics** – This appendix provides detailed schematic diagrams of the starter kit.

CONVENTIONS USED IN THIS GUIDE

This manual uses the following documentation conventions:

DOCUMENTATION CONVENTIONS

Description	Represents	Examples
Arial font:		
Italic characters	Referenced books	<i>MPLAB[®] IDE User's Guide</i>
	Emphasized text	...is the <i>only</i> compiler...
Initial caps	A window	the Output window
	A dialog	the Settings dialog
	A menu selection	select Enable Programmer
Quotes	A field name in a window or dialog	"Save project before build"
Underlined, italic text with right angle bracket	A menu path	<u><i>File>Save</i></u>
Bold characters	A dialog button	Click OK
	A tab	Click the Power tab
N'Rnnnn	A number in verilog format, where N is the total number of digits, R is the radix and n is a digit.	4'b0010, 2'hF1
Text in angle brackets < >	A key on the keyboard	Press <Enter>, <F1>
Courier New font:		
Plain Courier New	Sample source code	#define START
	Filenames	autoexec.bat
	File paths	c:\mcc18\h
	Keywords	_asm, _endasm, static
	Command-line options	-Opa+, -Opa-
	Bit values	0, 1
	Constants	0xFF, 'A'
Italic Courier New	A variable argument	<i>file.o</i> , where <i>file</i> can be any valid filename
Square brackets []	Optional arguments	mcc18 [options] <i>file</i> [options]
Curly brackets and pipe character: { }	Choice of mutually exclusive arguments; an OR selection	errorlevel {0 1}
Ellipses...	Replaces repeated text	var_name [, var_name...]
	Represents code supplied by user	void main (void) { ... }

WARRANTY REGISTRATION

Please complete the enclosed Warranty Registration Card and mail it promptly. Sending in the Warranty Registration Card entitles you to receive new product updates. Interim software releases are available at the Microchip web site.

RECOMMENDED READING

This user's guide describes how to use the MPLAB Starter Kit for PIC24H MCUs. Other useful documents are listed below. The following Microchip documents are available and recommended as supplemental reference resources.

Readme Files

For the latest information on Microchip tools, read the associated Readme files (HTML files) included with the software.

PIC24H MCU Documentation

For the most up-to-date information on PIC24H MCU devices (data sheets, errata, family reference manual, etc.), please see the Microchip web site at: [http\www.microchip.com](http://www.microchip.com).

MPLAB[®] C Compiler for PIC24 MCUs and dsPIC[®] DSCs User's Guide (DS51284)

This document helps you use Microchip's 16-bit C compilers to develop your application. The compilers are the MPLAB C Compiler for dsPIC DSCs and PIC24 MCUs, the MPLAB C Compiler for dsPIC DSCs (subset of the first), and the MPLAB C Compiler for PIC24 MCUs (subset of the first). These compilers are GNU-based language tools, based on source code from the Free Software Foundation (FSF). For more information about FSF, see www.fsf.org.

MPLAB[®] Assembler, Linker and Utilities for PIC24 MCUs and dsPIC[®] DSCs User's Guide (DS51317)

This document helps you use Microchip Technology's 16-bit language tools based on GNU technology. The language tools discussed are the MPLAB Assembler for dsPIC DSCs and PIC24 MCUs, MPLAB Object Linker for dsPIC DSCs and PIC24 MCUs, MPLAB Archiver/Librarian for dsPIC DSCs and PIC24 MCUs and other 16-bit device utilities.

MPLAB[®] IDE User's Guide (DS51519)

This document describes how to use the MPLAB IDE integrated development environment, as well as the MPLAB Project manager, MPLAB Editor and MPLAB SIM simulator. Use these development tools to help you develop and debug application code.

THE MICROCHIP WEB SITE

Microchip provides online support via our web site at www.microchip.com. This web site is used as a means to make files and information easily available to customers. Accessible by using your favorite Internet browser, the web site contains the following information:

- **Product Support** – Data sheets and errata, application notes and sample programs, design resources, user's guides and hardware support documents, latest software releases and archived software
- **General Technical Support** – Frequently Asked Questions (FAQs), technical support requests, online discussion groups, Microchip consultant program member listing
- **Business of Microchip** – Product selector and ordering guides, latest Microchip press releases, listing of seminars and events, listings of Microchip sales offices, distributors and factory representatives

DEVELOPMENT SYSTEMS CUSTOMER CHANGE NOTIFICATION SERVICE

Microchip's customer notification service helps keep customers current on Microchip products. Subscribers will receive e-mail notification whenever there are changes, updates, revisions or errata related to a specified product family or development tool of interest.

To register, access the Microchip web site at www.microchip.com, click on Customer Change Notification and follow the registration instructions.

The Development Systems product group categories are:

- **Compilers** – The latest information on Microchip C compilers and other language tools. These include 16-bit language tools:
 - MPLAB C Compiler for dsPIC DSCs and PIC24 MCUs (and subsets)
 - MPLAB Assembler for dsPIC DSCs and PIC24 MCUs
 - MPLAB Object Linker for dsPIC DSCs and PIC24 MCUs
 - MPLAB Archiver/Librarian for dsPIC DSCs and PIC24 MCUsand 8-bit language tools:
 - MPLAB C Compiler for PIC18 MCUs
 - MPASM[™] Assembler
 - MPLINK[™] Object Linker
 - MPLIB[™] Object Librarian
- **In-Circuit Emulators** – The latest information on Microchip in-circuit emulators. These include the MPLAB REAL ICE and MPLAB ICE 2000 in-circuit emulators.
- **In-Circuit Debuggers** – The latest information on Microchip in-circuit debuggers. These include MPLAB ICD 2, MPLAB ICD 3, and PICKit[™] 2.
- **MPLAB IDE** – The latest information on Microchip MPLAB IDE, the Windows[®] Integrated Development Environment for development systems tools. This list is focused on the MPLAB IDE, MPLAB IDE Project Manager, MPLAB Editor and MPLAB SIM simulator, as well as general editing and debugging features.
- **Programmers** – The latest information on Microchip programmers. These include the MPLAB PM3 device programmer and the PICSTART[®] Plus and PICKit 1 and 2 development programmers.

CUSTOMER SUPPORT

Users of Microchip products can receive assistance through several channels:

- Distributor or Representative
- Local Sales Office
- Field Application Engineer (FAE)
- Technical Support

Customers should contact their distributor, representative or field application engineer (FAE) for support. Local sales offices are also available to help customers. A listing of sales offices and locations is included in the back of this document.

Technical support is available through the web site at: <http://support.microchip.com>

DOCUMENT REVISION HISTORY

Revision A (November 2008)

This is the initial release of this document.

NOTES:



MPLAB[®] STARTER KIT FOR PIC24H MICROCONTROLLERS USER'S GUIDE

Chapter 1. Introduction

Thank you for purchasing Microchip Technology's MPLAB[®] Starter Kit for PIC24H Microcontrollers (MCUs). This kit is intended to introduce and demonstrate the features of the starter kit and the strong processing capabilities of PIC24H MCU devices.

The starter kit demonstrates a low-cost hardware and software solution for processing sensor signals and interfacing audio and visual displays. The board also includes signal conditioning circuitry, which helps users to perform a quick evaluation of the power of PIC24H MCUs by processing signals coming from an external sensor. In addition, the starter kit has on-board debug circuitry you can use to develop and debug your own applications without using other debug tools (i.e., in-circuit emulator or debugger).

This chapter introduces the starter kit and provides an overview of its features. Topics covered include:

- Overview
- Operational Requirements
- Board Setup

1.1 OVERVIEW

The MPLAB Starter Kit for PIC24H MCUs connects directly to the USB port on a personal computer (PC). The PC USB connection supplies communications and power to the board.

The starter kit includes debug and programmer circuitry that allows applications to be programmed onto the board's PIC24H MCU device and then debugged, all using MPLAB IDE.

The sensor signals from an on-board triaxial analog accelerometer are routed to the fast on-chip ADC module in the PIC24H MCU for software processing. This feature allows the Starter Kit to be maneuvered by tilting. Based on the sensed acceleration due to the tilting of the board, a visual output is generated on the on-board OLED display controlled by the Parallel Master Port (PMP) module. Additionally, the speech segments are audibly produced through the on-board speaker via the output compare module as a Pulse-Width Modulated (PWM) digital waveform. This output is converted to an analog speech signal by a low-pass filter on the starter kit board. Alternatively, applications can use the conditioning circuitry to plug-in a wide range of analog sensors, grab the sensor signals through the ADC and process them.

In addition to the Recommended Reading listed in the Preface, the following manufacturers' data sheets are also recommended as reference sources:

- Bosch Sensortec Data Sheet, *BMA140 Triaxial Analog Acceleration Sensor*
- National Semiconductor Corporation Data Sheet, *LM4853 Boomer[®] Audio Power Amplifier Series Mono 1.5W/ Stereo 300mW Power Amplifier (DS200334)*

1.2 OPERATIONAL REQUIREMENTS

To communicate with and program the MPLAB Starter Kit for PIC24H MCUs, the following hardware and software requirements must be met:

- PC-compatible system
- An available USB port on the PC or a powered USB hub
- CD-ROM drive
- Windows[®] 2000 SP4, Windows XP SP2, or Windows Vista (32-bit)⁽¹⁾ Operating Systems.

Note 1: Only initial testing has been performed on the 32-bit Windows Vista Operating System for this release. The 64-bit Windows Vista Operating System is not supported at this time.

1.3 BOARD SETUP

Figure 1-1 shows the setup for the MPLAB Starter Kit for PIC24H MCUs. The USB connection provides communication and power to the board. As soon as the starter kit is powered through the USB cable, the preloaded demonstration starts.

FIGURE 1-1: MPLAB STARTER KIT FOR PIC24H MCUs SETUP

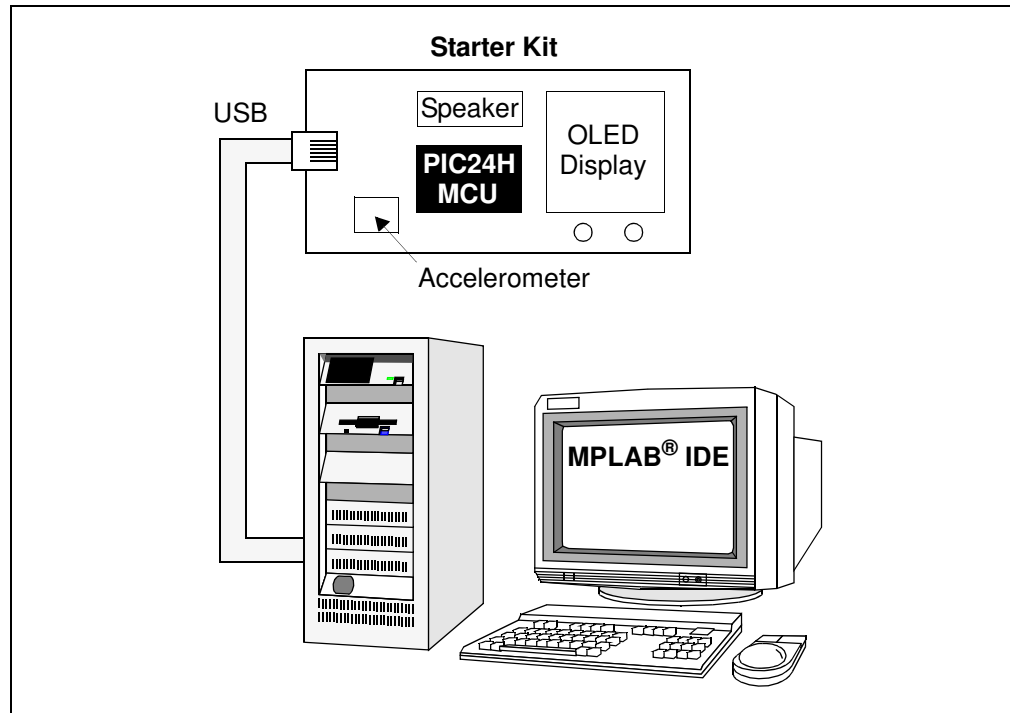

Chapter 2. Starter Kit Demo

This chapter describes the MPLAB® Starter Kit for PIC24H Microcontrollers demonstration that is preloaded on the PIC24H MCU device, which showcases the multitasking of accelerometer sensing, the OLED display, speech playback, and the switch press monitor. This software application demonstrates how to use the MPLAB Starter Kit for PIC24H MCUs for signal capture and processing of the sensor signal, speech decoding and playback, and controlling the OLED display.

A detailed explanation of the starter kit hardware is provided in **Chapter 4. "Hardware"**.

Topics covered include:

- Running the Demo
- Understanding the Demo
- Other Demo Code Examples

2.1 RUNNING THE DEMO

To run the demo, follow these steps:

1. Power-up the starter kit by connecting the board to the USB port of a computer. You should briefly see a pop-up message in the system tray that states (1) new hardware has been found, (2) drivers are being installed, and (3) new hardware is ready for use. If you do not see these messages and the starter kit does not work, try reconnecting the USB cable. If reconnecting the USB cable does not work, refer to **Section 3.8 "Troubleshooting"**.

When powered up, an audible welcome message is played while simultaneously displaying the Start-up screen on the OLED display (see Figure 2-1).

FIGURE 2-1: START-UP SCREEN

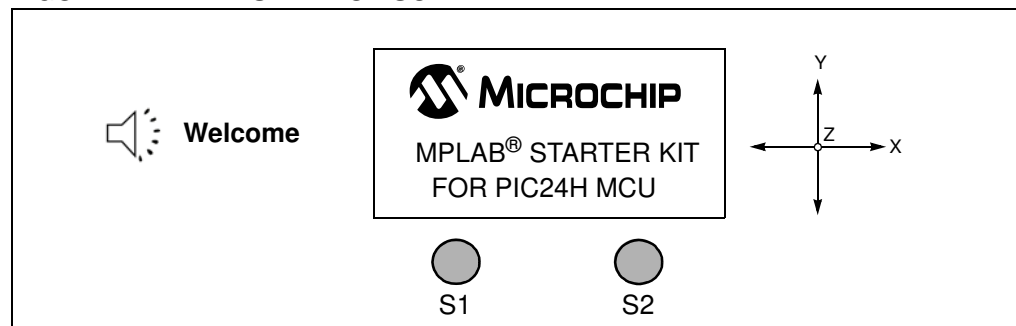

After the start-up exercise, the Home screen appears on the OLED display, as shown in Figure 2-2.

The Home screen has four cells from which to choose: Accelerometer (Acc.) Graph, External (Ext.) Sensor, Orientation and Games. The starter kit can be maneuvered by tilting it about the X and Y axes. Based on the direction of tilt, one of the four cells is highlighted for selection. Switch S1 or S2 can be pressed to select the highlighted cell.

FIGURE 2-2: STARTER KIT HOME SCREEN

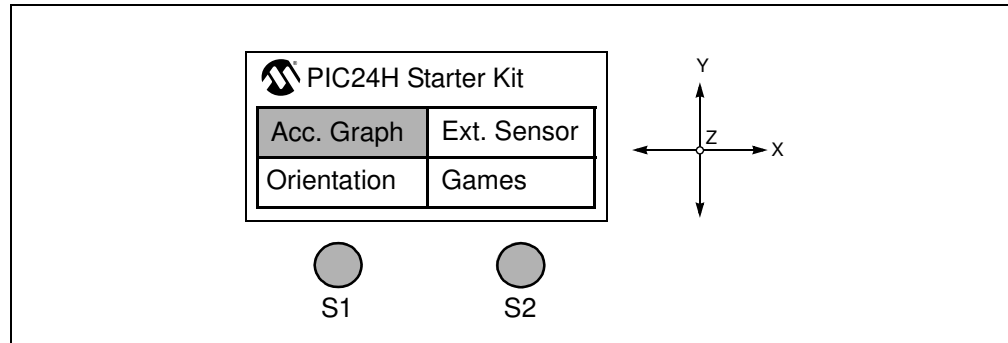

2. Selecting the **Acc. Graph** cell starts the application, which captures the triaxial outputs of the accelerometer and displays them on the OLED display as a graph, as shown in Figure 2-3. Switch S1 or S2 can be pressed at any time to return to the Home screen.

FIGURE 2-3: ACCELEROMETER GRAPH

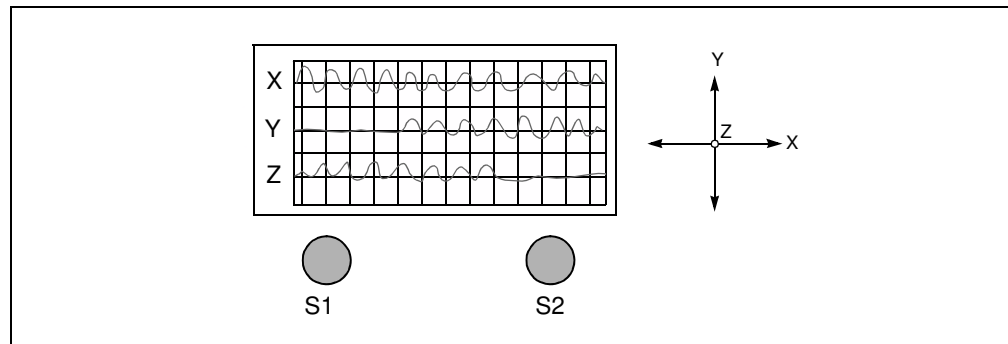

3. Selecting the **Ext. Sensor** cell (see Figure 2-4) starts the application, which captures the output of the external sensor that can be plugged-in at points TP12 and TP11.

FIGURE 2-4: SELECTING THE EXTERNAL SENSOR OPTION

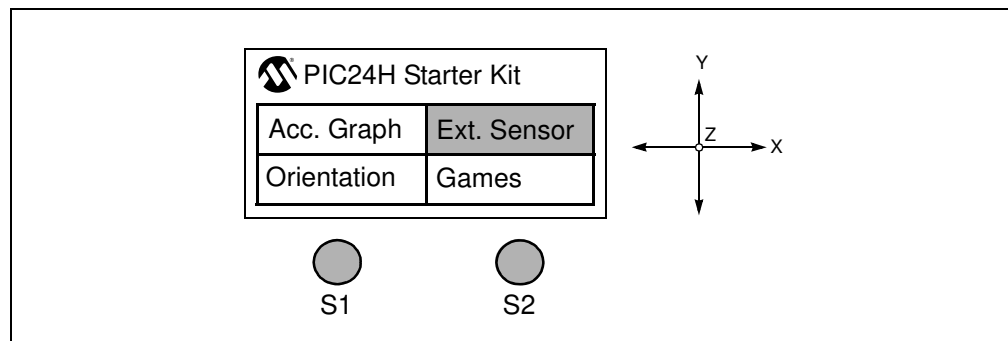

Before displaying the external sensor signal an information screen is displayed, which prompts the user to plug-in an external sensor, as shown in Figure 2-5.

FIGURE 2-5: EXTERNAL SENSOR PROMPT

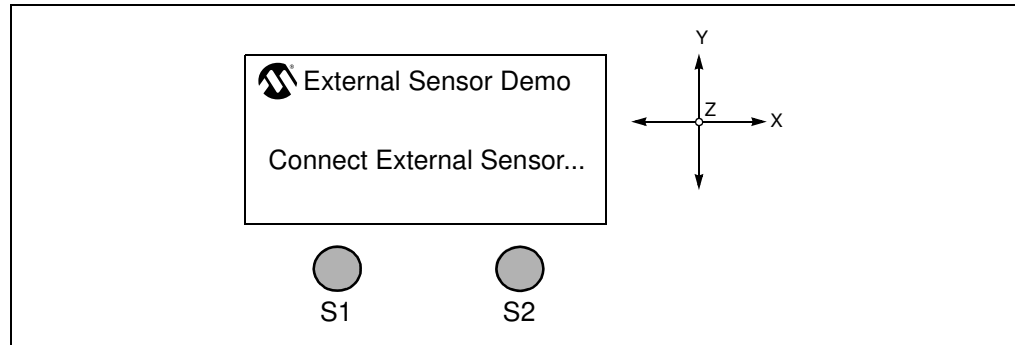

Switch S1 can be pressed to slow down or speed up the display (see Figure 2-6) in case the displayed signal is too fast or too slow.

FIGURE 2-6: EXTERNAL SENSOR SIGNAL

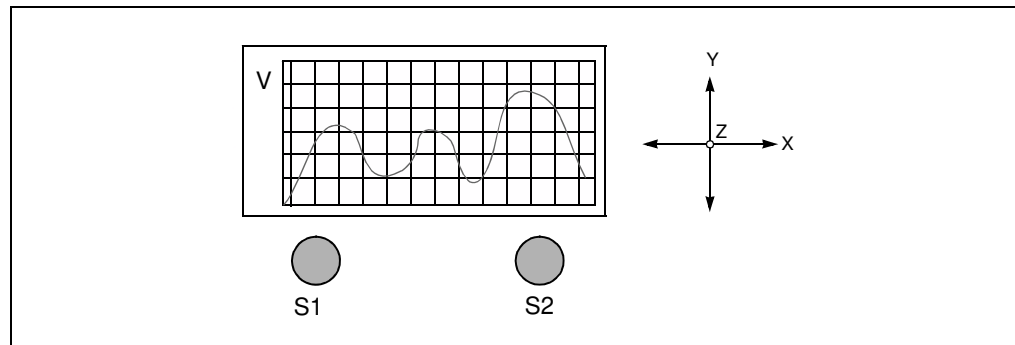

Switch S2 can be pressed at any time to return to the Home screen.

4. Selecting the **Orientation** cell (see Figure 2-7) starts the application, which indicates the orientation of the starter kit.

Patterns are displayed on the OLED display and messages are played out on the speaker indicating *Portrait*, *Landscape* and *Plane* orientations (see Figure 2-8). The acceleration in each of the axes is displayed on the left side of the screen as a fraction of gravitational acceleration constant on earth, $1g = 9.8 \text{ m/s}^2$.

FIGURE 2-7: SELECTING THE ORIENTATION OPTION

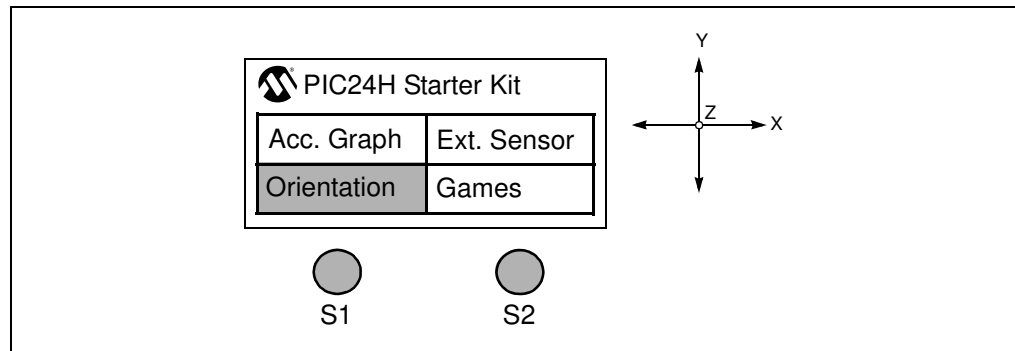
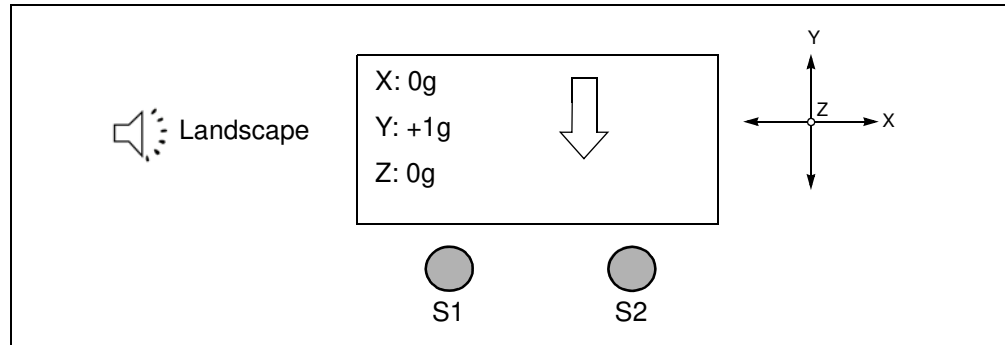
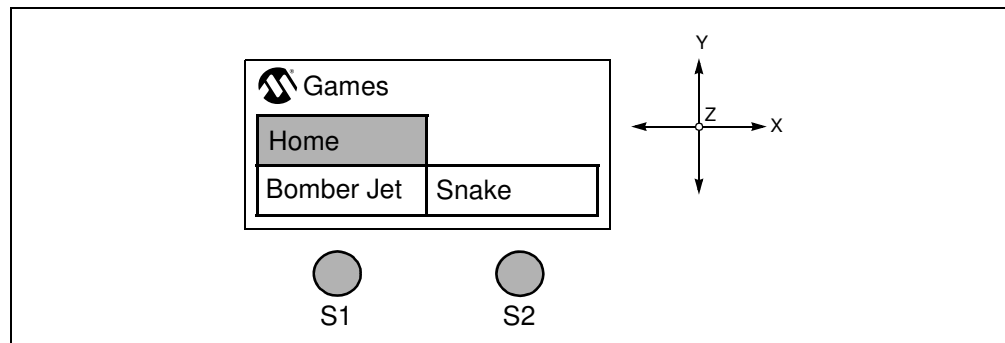

FIGURE 2-8: ORIENTATION PATTERNS



5. Selecting the **Games** cell displays a new screen with three cells: Home, Bomber Jet and Snake, as shown in Figure 2-9.

FIGURE 2-9: GAMES SCREEN



Selecting the Home cell will return you to the Home screen.

6. Selecting the **Bomber Jet** cell starts the Bomber Jet game.
 The Jet can be maneuvered on the X and Y planes of the display by tilting the starter kit about X and Y axes. Asteroids and alien ships are encountered in the game. The jet should be maneuvered such that it doesn't collide with the asteroid, alien ship, and isn't hit by a missile from the alien ship. Pressing switch **S1** turns on a protective shield, momentarily. The shield will destroy any asteroid or alien ship missile in its path. Pressing **S2** releases missiles from the Bomber Jet. The alien ships and the asteroids are destroyed when hit by the missiles from the Bomber Jet. See Figure 2-10 for an example of the display during game play.

FIGURE 2-10: BOMBER JET GAME

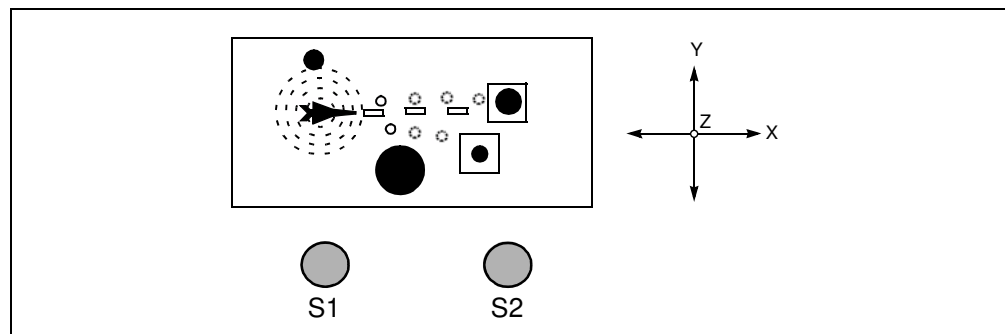

The score increases whenever a missile fired by the Bomber Jet missile strikes an alien ship or an asteroid. Using the protective shield decreases the score. The game automatically exits to a Score screen after achieving a score of 1000 or when hit by an alien missile, or colliding with an alien ship or asteroid (see Figure 2-11).

FIGURE 2-11: BOMBER JET GAME SCORE

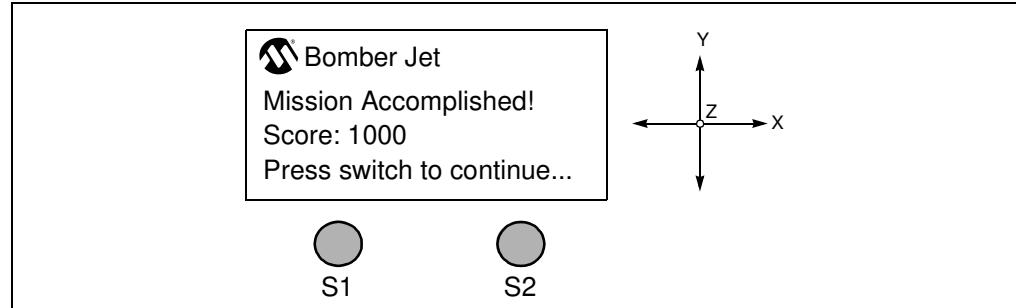

After the Score screen appears, Switch **S1** or **S2** can be pressed at any time to return to the Games screen.

7. Selecting the **Snake** cell starts the Snake game.

The snake can be maneuvered on the X and Y plane of the display by tilting the starter kit about X and Y axes. Multiple snake food appears, which the snake must eat. The snake grows in size when it eats. The snake should be maneuvered to eat the food such that it doesn't collide with any of the four walls. See Figure 2-12 for an example of the display during game play.

FIGURE 2-12: SNAKE GAME

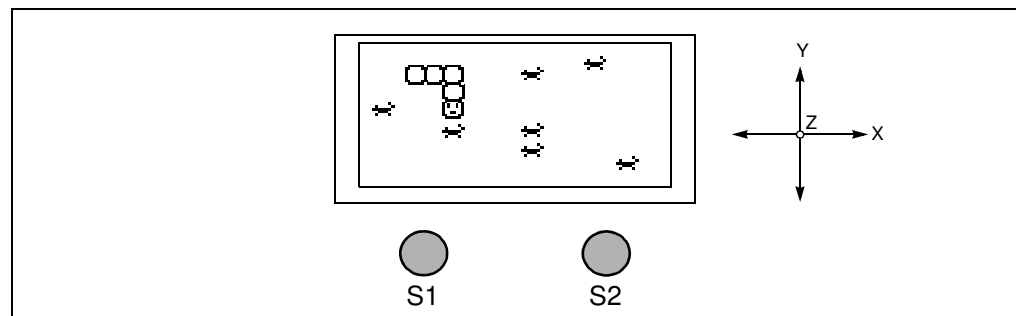

The score increases if the snake eats food. The game automatically exits to a Score screen after the snake grows a tail length of 25 rings or the snake hits any of the four walls (see Figure 2-13).

FIGURE 2-13: SNAKE GAME SCORE

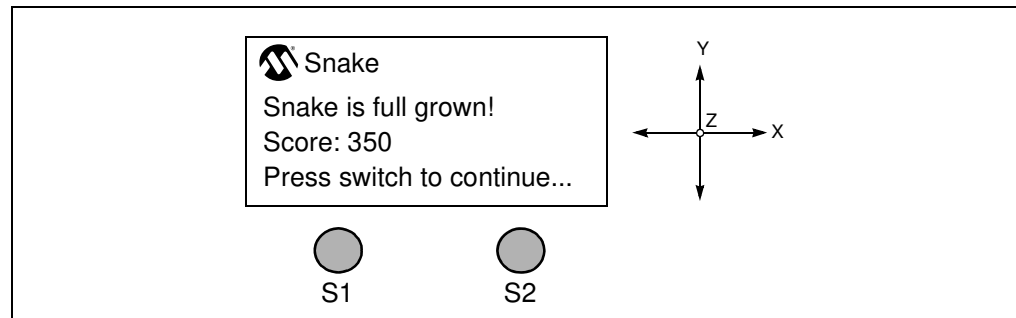

After the Score screen appears, switch **S1** or **S2** can be pressed at any time to return to the Games screen.

2.2 UNDERSTANDING THE DEMO

The PIC24H MCU device on the starter kit is pre-programmed with the main application demonstration. The CD that accompanies the starter kit also contains the main application code. As shown in Figure 2-14, this sample application uses the board to capture the triaxial acceleration signals from the accelerometer, and plays speech messages through the speaker with a visual display on the OLED display.

The board also features conditioning circuitry that provides the user the flexibility of plugging in a wide range of sensors and performing signal processing on the captured sensor signals.

Detailed descriptions of the basic modules are provided in **Chapter 4. "Hardware"**. The following sections give a brief functional description of these modules.

FIGURE 2-14: STARTER KIT BOARD

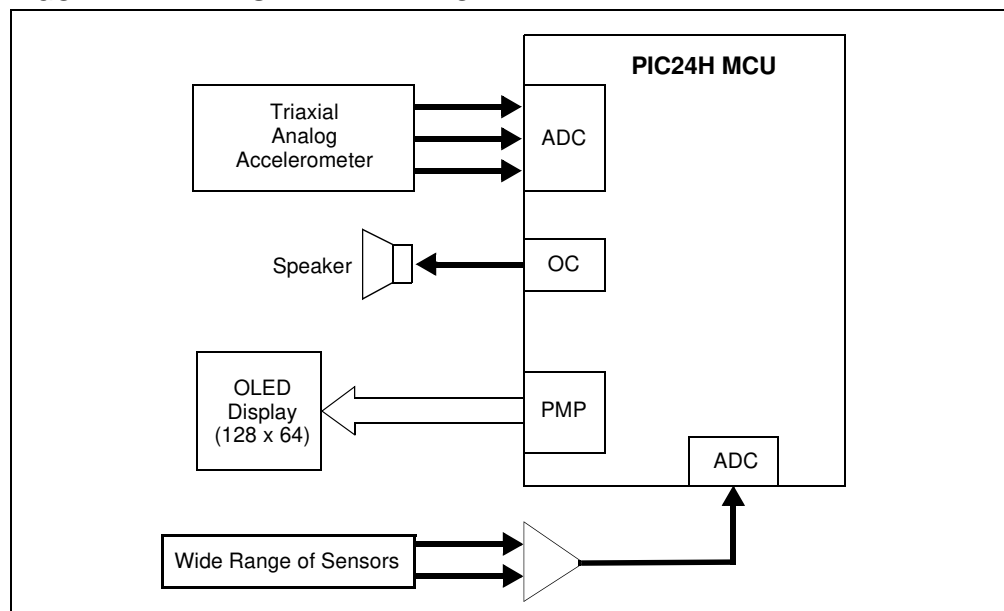

2.2.1 Accelerometer Interface

The starter kit has a triaxial analog accelerometer. The three (X, Y and Z) acceleration outputs are captured using the ADC module on the PIC24H MCU device. The ADC-captured accelerometer samples are processed differently in the PIC24H MCU based on the game chosen.

2.2.2 OLED Display Interface

The starter kit has a 128 x 64 OLED display. Different screens are displayed for the user to choose from. Depending on the stimulus obtained from the accelerometer and the switches, different screens are displayed, signals are graphed and games are controlled.

2.2.3 Speaker Interface

The speaker plays messages. The speech messages are compressed using the G.711 A-law and are stored in the program memory of the PIC24H. The PIC24H decodes the compressed data and generates PWM signals which are demodulated before being output through the speaker.

2.2.4 External Sensor Interface

The starter kit features an analog conditioning circuit which can be used by the user to plug in a wide range of external sensors. The differential output of the sensor flows through a differential amplifier and an anti-aliasing filter before being sampled by the on-chip ADC.

2.3 OTHER DEMO CODE EXAMPLES

The starter kit software CD includes another demo code example, External_Sensor_Demo.

The External_Sensor_Demo code example demonstrates the low-cost sensor signal capture and processing. When a sensor is plugged into the analog conditioning circuitry the code example captures the sensor signal through the ADC channel. The captured discrete time sensor signal can be processed inside the code example. Instructions are provided in the source file as to where user desired signal processing routines need to be added to process the sensor signal captured by the ADC.

The characteristics of the external analog sensor that can be used are provided in **Section 4.1.4 “Analog Conditioning Circuitry”**.

NOTES:

Chapter 3. Develop an Application

The MPLAB Starter Kit for PIC24 MCUs may be used with MPLAB[®] IDE, the free integrated development environment available on Microchip's web site. MPLAB IDE allows the starter kit to be used as an in-circuit debugger as well as a programmer for the featured device.

In-circuit debugging allows you to run, examine, and modify your program for the device embedded in the starter kit hardware. This greatly assists you in debugging your firmware and hardware together.

Special starter kit software interacts with the MPLAB IDE application to run, stop, and single-step through programs. Breakpoints can be set and the processor can be reset. Once the processor is stopped, the register's contents can be examined and modified.

For more information on how to use MPLAB IDE, reference the following documentation:

- *MPLAB[®] IDE User's Guide* (DS51519)
- *MPLAB[®] IDE Quick Start Guide* (DS51281)
- MPLAB[®] IDE On-line Help

This chapter includes the following:

- Installing the Hardware and Software
- Setting Up an Example Application for Debug
- Running the Example Application
- Debugging the Example Application
- Programming the Debugged Application
- Creating Other PIC24H MCU Applications
- Determining Device Support and Reserved Resources
- Troubleshooting
- Settings Dialog, Info Tab

3.1 INSTALLING THE HARDWARE AND SOFTWARE

To install the hardware:

If you have not already set up the hardware to run the demo, follow these steps:

1. Power-up the starter kit by connecting the board to the USB port of a computer.
You should briefly see a pop-up balloon in the system tray that states (1) new hardware has been found, (2) drivers are being installed, and (3) new hardware is ready for use. If you do not see these messages and the starter kit does not work, try reconnecting the USB cable. If reconnecting the USB cables does not work, see **Section 3.8 "Troubleshooting"**.
2. When powered up, the application starts and runs as described in Section 2.1.

To install the software:

Run the CD-ROM enclosed with the starter kit and install the software as directed.

3.2 SETTING UP AN EXAMPLE APPLICATION FOR DEBUG

The MPLAB IDE software that is installed on your PC by the starter kit CD-ROM automatically opens an example application that you may use to examine debug features of the starter kit.

To prepare the application for debug:

1. Launch MPLAB IDE. The example application project and related workspace will open. For information on projects and workspaces, see the MPLAB IDE documentation mentioned at the beginning of this chapter.
2. Select *Project>Build All* to build the application code. The build's progress will be visible in the Build tab of the Output window.
3. Select *Debugger>Select Tool>Starter Kits*. MPLAB IDE will change to add starter kit debug features (Figure 3-1): (1) the status bar will show Starter Kits as the debug tool, (2) a Starter Kit debug toolbar will be added, (3) the Debugger menu will change to add Starter Kit debug functions and (4) the Output window will display communication status between MPLAB IDE and the starter kit on the **Starter Kit Debugger** tab.

Also, several device resources are used for debug. For details, see **Section 3.7 "Determining Device Support and Reserved Resources"**.

FIGURE 3-1: STARTER KIT AS DEBUG TOOL

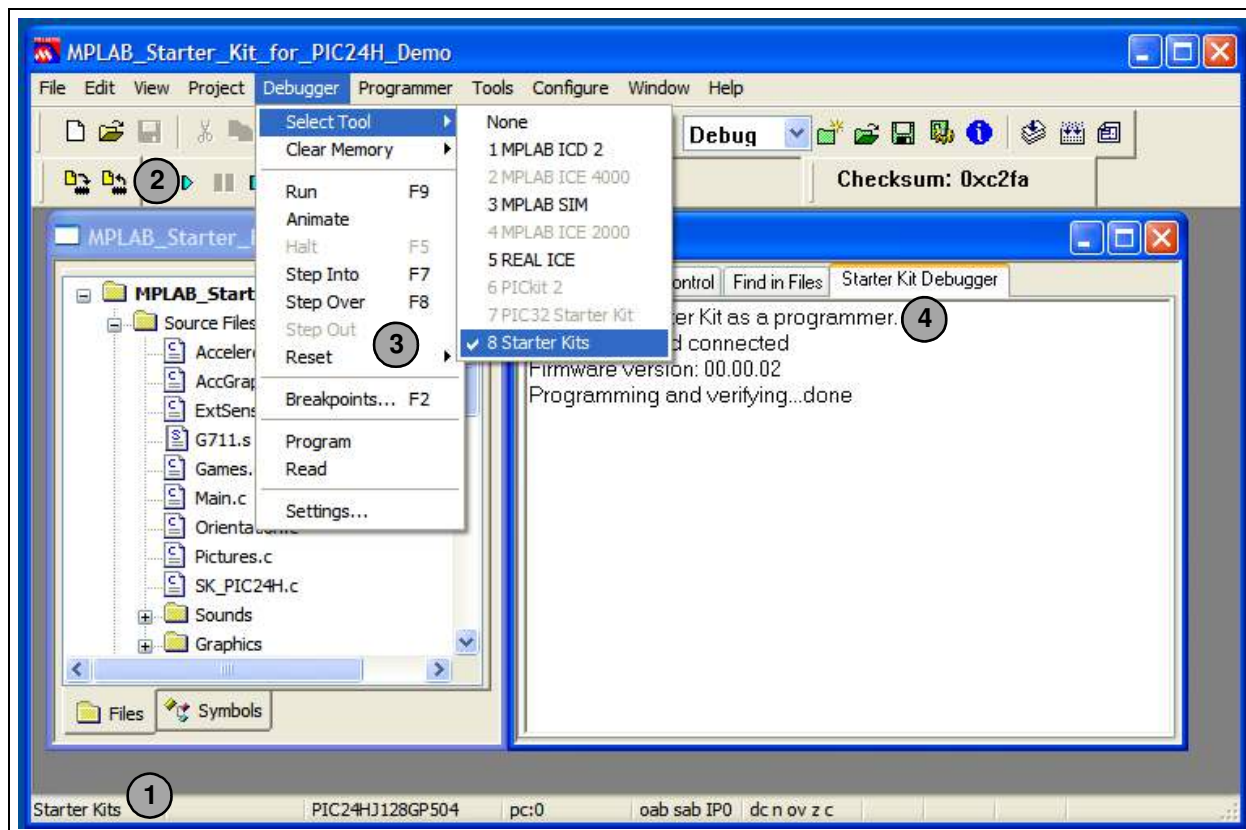

4. Select *Debugger>Program* to program the application code into the PIC24H MCU device on the starter kit. The debug programming progress will be visible in the **Starter Kit** tab of the Output window.









Note: Debug executive code is automatically programmed in the upper program memory of the starter kit device when the starter kit is selected as a debugger. Debug code must be programmed into the target device to use the in-circuit debugging capabilities of the starter kit.

3.3 RUNNING THE EXAMPLE APPLICATION

The starter kit executes in either real-time (Run) or steps (Step Into, Step Over, Animate). Real-time execution occurs when you select **Run** in MPLAB IDE. Once the device code is halted, either by **Halt** or a breakpoint, you can step.

The toolbar buttons shown in Table 3-1 can be used for quick access to commonly used debug operations:

TABLE 3-1: TOOLBAR BUTTONS

Debugger Menu	Debug Toolbar	Debugger Menu	DSK Toolbar
Run		Program	
Halt		Read	
Animate			
Step Into			
Step Over			
Reset			
Breakpoints			

To see how these options function, do the following:

1. Select *Debugger>Reset>Processor Reset* or click **Reset** to reset the program.
2. Select *Debugger>Run* or click **Run**. Observe how the application operates.
3. Select *Debugger>Halt* or click **Halt** to stop the program execution. A green solid arrow will mark the line of code in the File window where the program halted.
4. Select *Debugger>Step Into* or click **Step Into** to step the program execution once. The green solid arrow will move down one line of code in the File window. Click the button several times to step through some code.
5. Select *Debugger>Reset>Processor Reset* click **Reset** to reset the program again. The arrow will disappear, meaning the device is reset.

3.4 DEBUGGING THE EXAMPLE APPLICATION

For the example code given, everything works fine. However, when you are developing code, it will likely not work the first time and may need to be debugged. MPLAB IDE provides an editor and several debug features, such as breakpoints and Watch windows, to aid in application code debugging.

This section includes:

- Editing Application Code
- Using Breakpoints and Mouseovers
- Using Watch Windows

3.4.1 Editing Application Code

To view application code so it may be edited, do one of the following:

1. Select Edit>New to create new code or Edit>Open to search for and open an existing code file.
2. Double click a file in the Project window to open an existing code file. See an example Project window in Figure 3-2.

FIGURE 3-2: EXAMPLE PROJECT

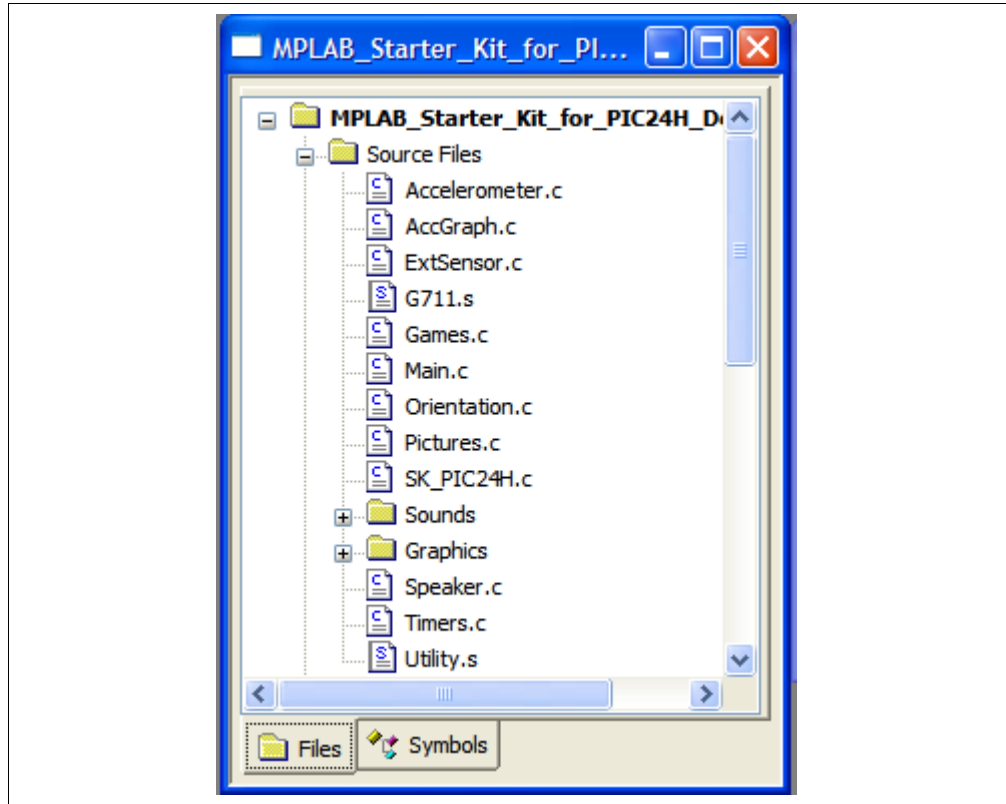

For more information on using the editor to create and edit code, see MPLAB Editor Help.

3.4.2 Using Breakpoints and Mouseovers

To set a breakpoint in code:

1. **Double Click the Gutter** – Double click in the window gutter next to the line of code where you want the breakpoint. Double click again to remove the breakpoint.

Note: Double click must be set up for breakpoints. See the Edit>Properties, ASM/C/BAS File Type tab, and the check box for “Double-click Toggles Breakpoint”.

2. **Pop-up Menu** – Place the cursor over the line of code where you want the breakpoint. Then, right click to pop up a menu and select “Set Breakpoint”. Once a breakpoint is set, “Set Breakpoint” will become “Remove Breakpoint” and “Disable breakpoint”. Other options on the pop-up menu under Breakpoints are for deleting, enabling, or disabling all breakpoints.
3. **Breakpoint Dialog** – Open the Breakpoint dialog (Debugger>Breakpoints) to set, delete, enable or disable breakpoints. See MPLAB IDE Help for more information on this dialog.

A breakpoint set in code will appear as a red hexagon with a “B” as shown in Figure 3-3.

FIGURE 3-3: EXAMPLE BREAKPOINT

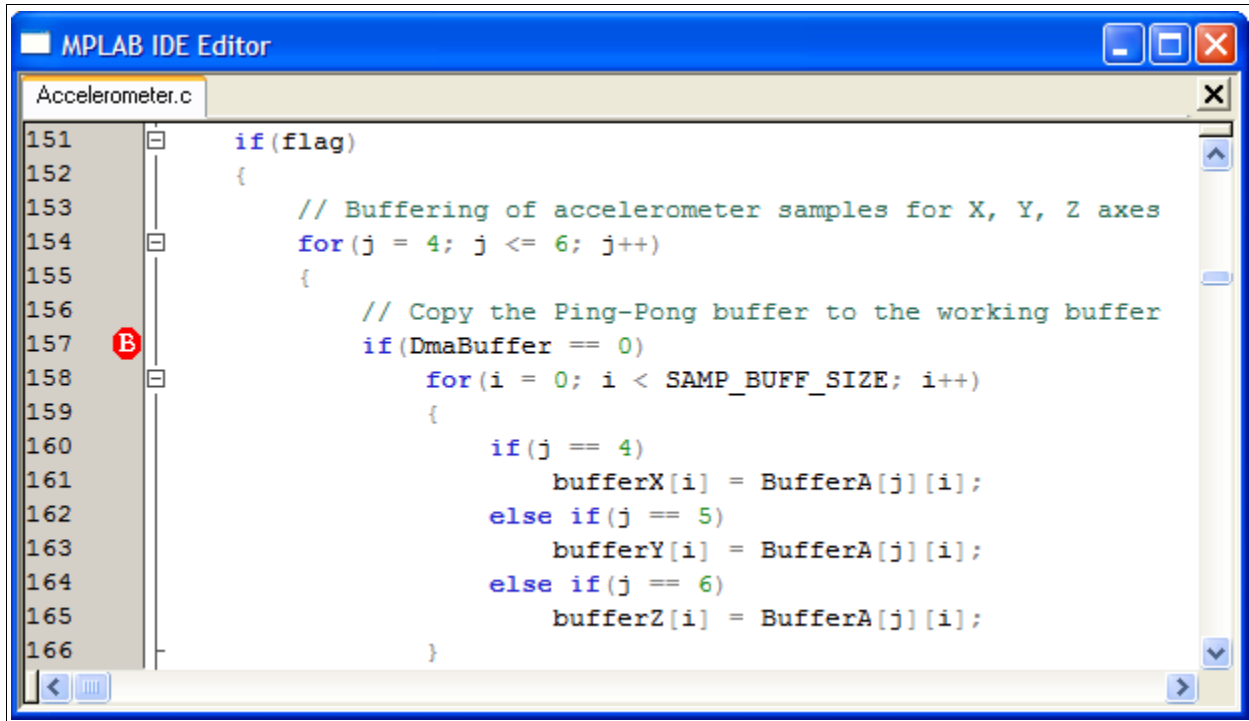

Once code is halted, hovering over variables pops up the current value of those variables (see Figure 3-3.)

Note: This feature must be set up. See the *Edit>Properties, Tooltips* tab, and check the “Enable Variable Mouseover Values” check box.

3.4.3 Using Watch Windows

To use a Watch window:

1. The Watch window is made visible on the desktop by selecting *View>Watch*. It contains four selectable Watch views (via tabs) in which to view variables (SFRs, symbols and absolute addresses).
2. Select an SFR or Symbol from the list and click the related **Add** button to add it to the Watch window. Or click the “Address” column and enter an absolute address.

A Watch window populated with SFRs and Symbols will look like Figure 3-4. For more information on using Watch windows, see MPLAB IDE Help.

FIGURE 3-4: EXAMPLE WATCH

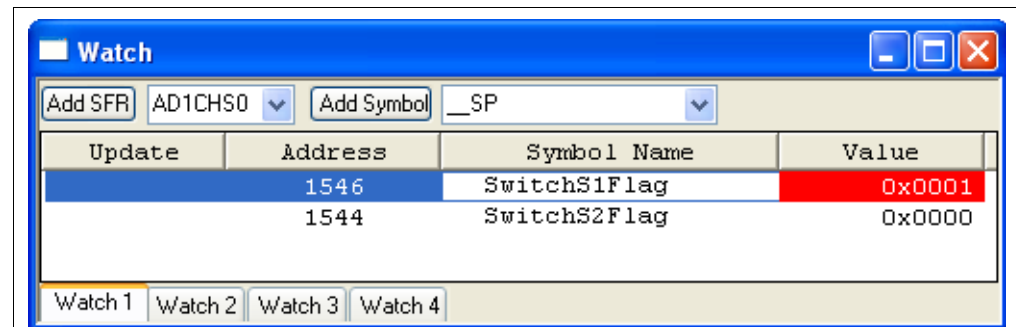

3.5 PROGRAMMING THE DEBUGGED APPLICATION

When the program is successfully debugged and running, the next step is to program the device for stand-alone operation in the finished design. When doing this, the resources reserved for debug are released for use by the application.

To program the application, use the following steps:

1. Disable Starter Kits as a debug tool by selecting *Debugger>Select Tool>None*.
2. Select Starter Kits as the programmer in the *Programmer>Select Programmer* menu.
3. Select *Programmer>Program*.

Now the starter kit will run independently.

3.6 CREATING OTHER PIC24H MCU APPLICATIONS

This starter kit is just one way to use Microchip PIC24H MCUs in an application. Other tools and resources exist to support these devices.

- PIC MCU Development Boards – Many boards are available for developing applications. See our web site (<http://www.microchip.com/>) under Design>Development Tools>Demo Boards>PIC MCU.
- MPLAB C Compiler for dsPIC[®] DSCs and PIC24 MCUs, Full Version – More optimization options than the student version for full-scale development. See <http://www.microchip.com/c30>.
- Application Notes – Example applications with code for using PIC24H MCU features. See our web site (<http://www.microchip.com/>) under Design>App Notes & Source Code>16-bit PIC MCUs & dsPIC DSCs.

3.7 DETERMINING DEVICE SUPPORT AND RESERVED RESOURCES

Due to the built-in in-circuit debugging capability of ICD devices and the ICSP[™] function offered by the debugger, the starter kit uses some on-chip resources when debugging. It also uses program memory and file register locations in the target device during debugging. These locations are not available for use by user code. In the MPLAB IDE, registers marked with an “R” in register displays represent reserved registers.

For information on device resources that are needed for in-circuit debugging, please refer to the MPLAB ICD 2 Help, found in MPLAB IDE under *Help>Topics*. The device reserved resource information found under “Resources Used By MPLAB ICD 2” is the same for the starter kit.

3.8 TROUBLESHOOTING

3.8.1 Debug Connection Problems

While using the starter kit as a debugger, you may get the error “Unable to Enter Debug Mode” when programming the device. This can result from communication being lost between the starter kit and MPLAB IDE. To resolve this:

1. Unplug the USB cable from the starter kit.
2. Plug the USB cable back into the starter kit.

MPLAB IDE should automatically reconnect to the starter kit. If this does not work, do the following:

1. Check the USB connection between the PC and starter kit at both ends.
2. If using a USB hub, make sure it is powered.
3. Make sure the USB port is not in use by another device.

3.8.2 Programming Problems

If during the course of developing your own application you can no longer program the device on the starter kit, you may have set device Configuration bits to code-protect or some other state that prevents programming. To view the settings of the Configuration bits, select *Configure>Configuration Bits*.

3.8.3 Build Problems

When using the starter kit as a debugger, make sure that the Build Configuration (drop-down list on the toolbar or item on the Debugger menu) is set to “Debug” or your code will not build correctly for debugging. When using the starter kit as a programmer, make sure that the Build Configuration is set to “Release” or your code will not build correctly for programming.

3.9 SETTINGS DIALOG, INFO TAB

When you select *Debugger>Settings* or *Programmer Settings*, you will open the Starter Kit Settings dialog.

Currently, there is only one (**Info**) tab on this dialog, displaying the following information:

- Firmware Version: The version of firmware on the starter kit board.
- Debug Exec Version: The version of the debug executive that is loaded into the device program memory to enable debug operation.

NOTES:

Chapter 4. Hardware

This chapter provides a functional overview of the hardware used in the MPLAB Starter Kit for PIC24H MCUs and identifies the major hardware components.

Topics covered include:

- Application Functional Overview
- Debug Functional Overview
- Board Components

4.1 APPLICATION FUNCTIONAL OVERVIEW

The block diagram shown in Figure 4-1 illustrates the mainstream operation of the starter kit.

FIGURE 4-1: STARTER KIT APPLICATION BLOCK DIAGRAM

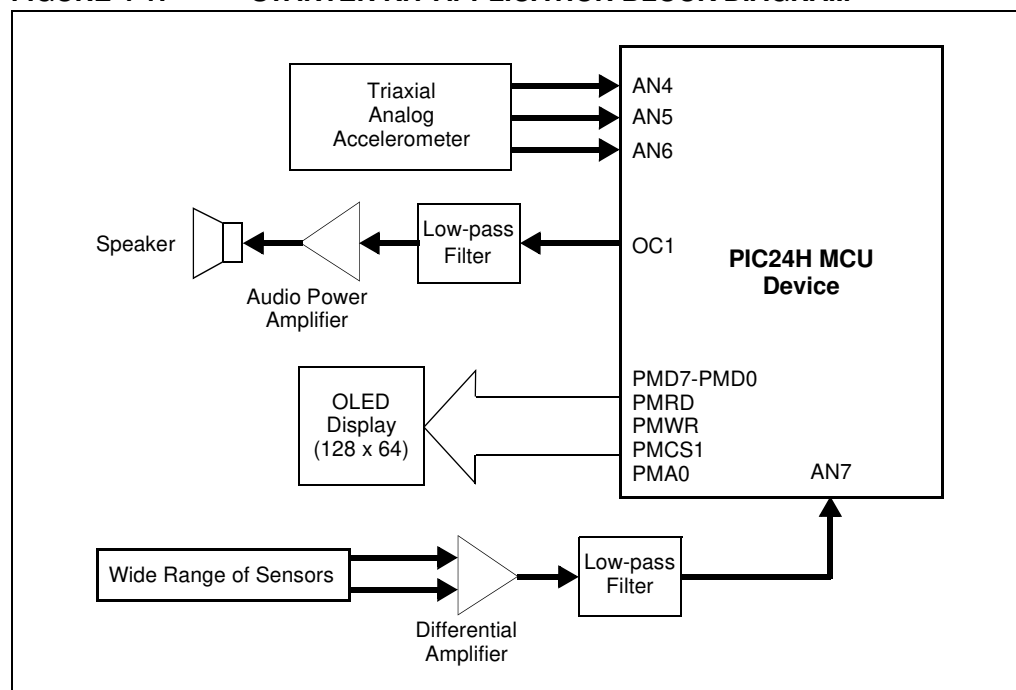

4.1.1 Accelerometer Interface

The starter kit has a triaxial analog accelerometer (see schematics in Figure A-2). The accelerometer has three analog outputs, one for each of the three spatial dimensions (3D - X, Y, and Z). These three acceleration outputs are captured using the ADC inputs AN4, AN5 and AN6, respectively, on the PIC24H MCU device. The ADC is set to perform simultaneous sampling. The direction of acceleration and associated spatial dimensions can be observed in the Figure 4-2.

FIGURE 4-2: DIRECTION OF ACCELERATION AND ASSOCIATED SPATIAL DIMENSIONS FOR THE TRIAXIAL ANALOG ACCELEROMETER

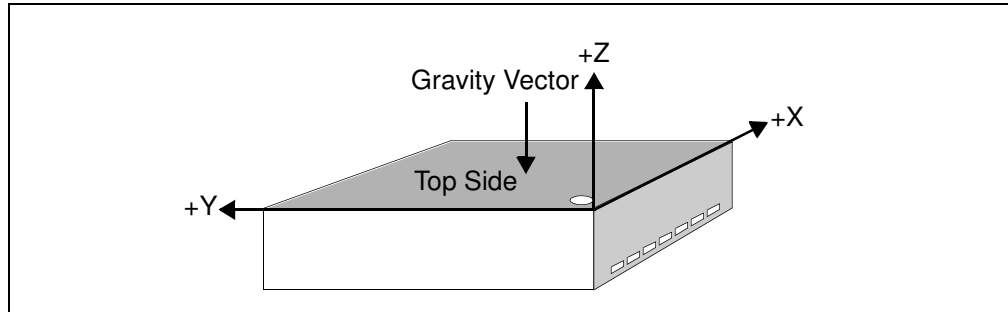

4.1.2 OLED Display Interface

The starter kit has a 128 x 64 pixel, monochrome organic LED array, which provides a wide range of graphics and alphanumeric display options. It is interfaced to the PIC24H MCU through the Parallel Master Port (PMP) module. The application uses the Microchip Graphics Library to communicate with the OLED display.

4.1.3 Speaker Interface

The speech messages are compressed using the G.711 A-law and are stored in the program memory of the PIC24H MCU. The wave files were G.711 compressed by using the dsPIC33F Speech Encoder Utility for G.711 provided on the CD and also available on the Microchip web site. When the demo application is running, the compressed speech messages are loaded from the program memory and decompressed using the G711 A-law decode algorithm and played out as a Pulse Width Modulated (PWM) signal using the output compare module on the PIC24H. This signal is passed through a 4th-order low-pass filter. This behaves like an integrator, whose output signal amplitude and frequency depends on the duty cycle of the input PWM waveform. The PWM frequency should be an integral multiple of the audio sampling rate. The output of this low-pass filter feeds an audio amplifier. The speaker is driven by an audio power amplifier (LM4853 Boomer). The speaker has a frequency range of 600 Hz to 22 kHz, with 8 Ohm impedance and rated power of 1W. See the schematics in Figure A-3.

FIGURE 4-3: PWM DEMODULATION

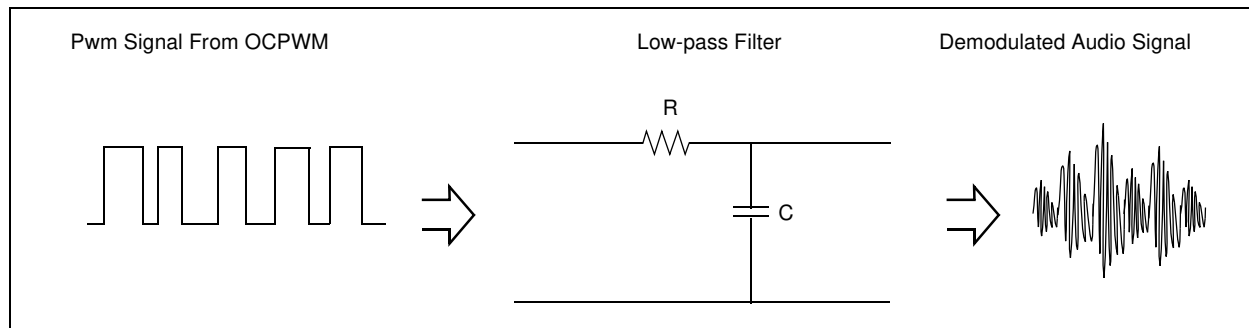

4.1.4 Analog Conditioning Circuitry

The starter kit features an analog conditioning circuit (see schematics in Figure A-4), which can be used by the user to plug in a wide range of external analog sensors. The analog conditioning circuit has a differential amplifier followed by an anti-aliasing low pass filter. The gain of the differential amplifier is given by Equation 4-1 in terms of the resistors used and differential input voltages at input points TP11 and TP12. The gain is fixed at 100. Any sensor with a differential compensated output voltage of less than 33mV can be used.

EQUATION 4-1: DIFFERENTIAL AMPLIFIER GAIN

$$\begin{aligned} Gain &= \frac{R_f}{R_i}(V_{TP11} - V_{TP12}) \\ R_f &= R57 = R58 \\ R_i &= R51 = R53 \end{aligned}$$

The anti-aliasing filter is a 2nd-order low-pass filter, with a cut-off frequency of ~500 Hz (483.78 Hz). The highest frequency of the base band sensor signal is assumed to be less than 500 Hz. The output of the low-pass filter is connected to the ADC input AN7 on the PIC24H MCU device.

4.2 DEBUG FUNCTIONAL OVERVIEW

The block diagram shown in Figure 4-4 illustrates the debugging/programming operation of the starter kit.

FIGURE 4-4: STARTER KIT DEBUG BLOCK DIAGRAM

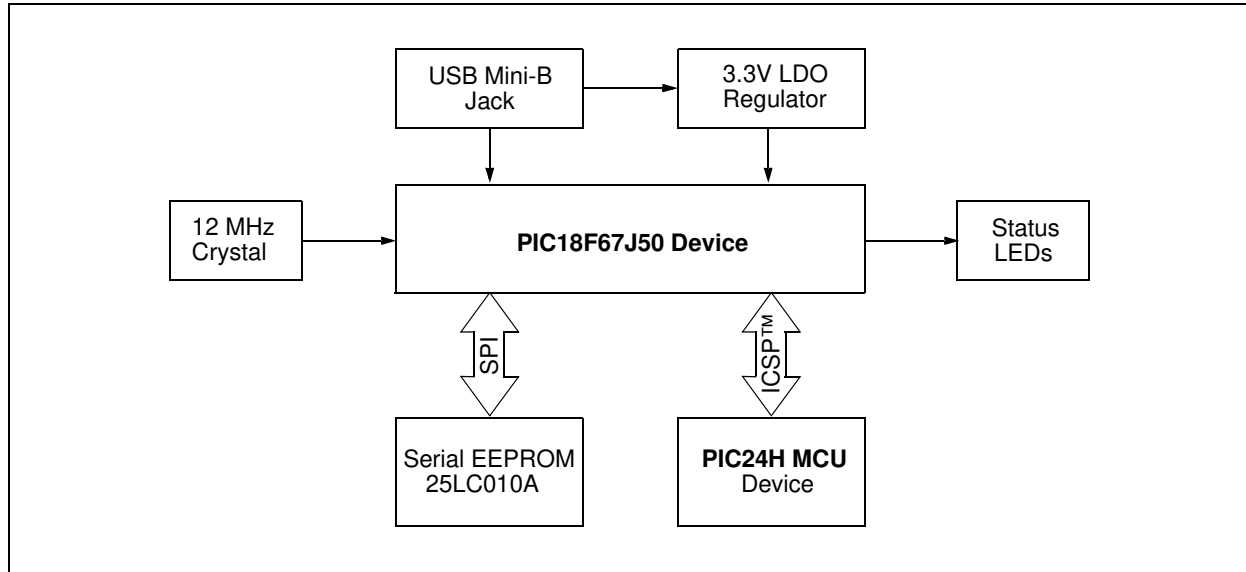

The starter kit, with its built-in debugger/programmer, provides an all-in-one solution for debugging and programming applications using MPLAB IDE. Also, no additional external power supply is needed as power is supplied by the host PC's USB port. See the schematics in Figure A-7 and Figure A-8.

The starter kit's debugging/programming operations are controlled by a PIC18F67J50 MCU running at 48 MHz. The PIC18F67J50's built-in USB engine provides the communications interface between the starter kit and the host PC.

Power to the starter kit is provided via USB, whose nominal 5V unregulated supply is regulated by a Microchip MC1727 3.3V low-dropout (LDO) linear regulator. Proper starter kit main system power is indicated by the green LED, D1.

The PIC18F67J50 MCU accomplishes debugging or programming of the target PIC24HJ128GP504 by controlling the target's PGC1/EMUC1 and PGD1/EMUD1 signals. Target power is switched on/off via a low V_{CE} saturation PNP transistor configured as a high-side switch. Target clocking is also provided by the PIC18F67J50 MCU.

A Microchip 25LC010A serial EEPROM is used to store the starter kit's serial number and debug control information.

4.3 BOARD COMPONENTS

Figure 4-5 identifies the key starter kit hardware components. Table 4-1 provides descriptions for the hardware components.

FIGURE 4-5: STARTER KIT

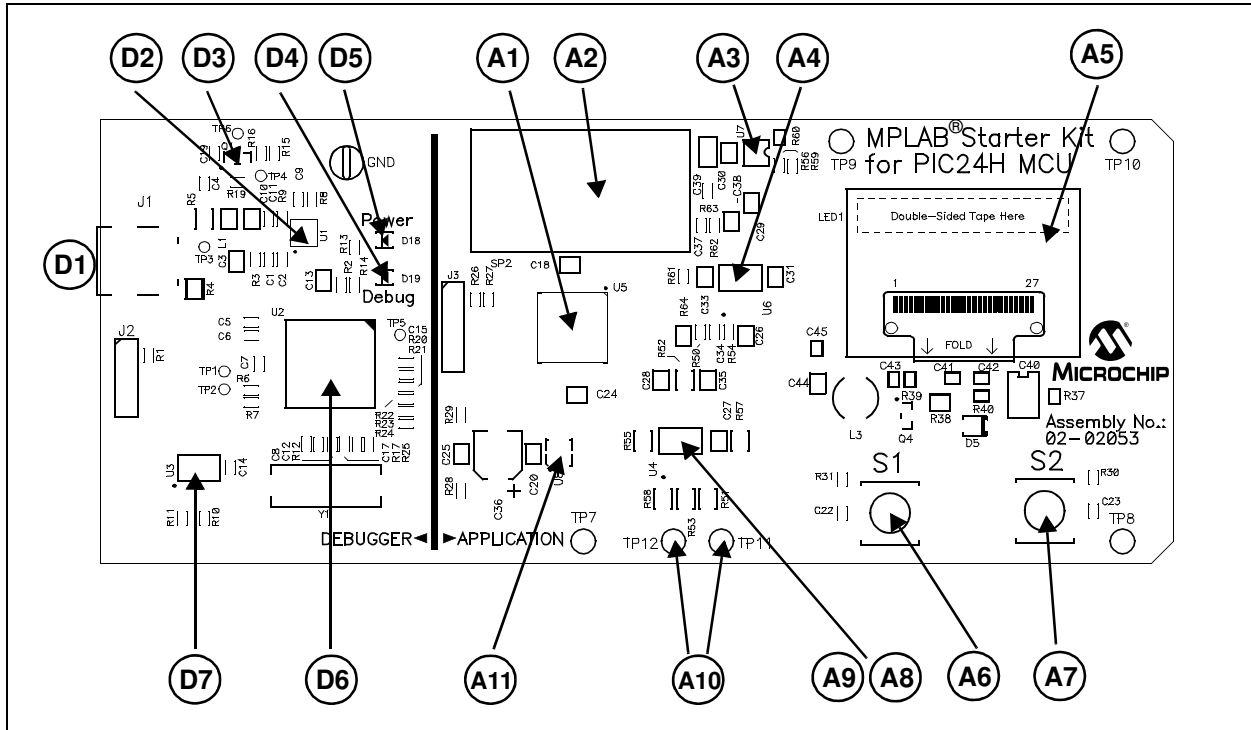

TABLE 4-1: STARTER KIT HARDWARE COMPONENT DESCRIPTIONS

Ref	Component	Ref	Component
D1	Mini-B USB Connector (J1)	A3	Audio Power Amplifier (U7)
D2	MCP1727 (U1)	A4	Anti-Aliasing Low-Pass Filter (Speech) (U6: A, B)
D3	Low VCE Saturation PNP Transistor Switch (Q1)	A5	OLED Display (LED)
D4	Debug Status LED (D18)	A6	Switch S1
D5	System Power STATUS LED (D19)	A7	Switch S2
D6	PIC18F67J50 MCU (U2)	A8	Differential Amplifier (External Sensor) (U4: A)
D7	25LC010A SERIAL EEPROM (U3)	A9	Anti-Aliasing Low-Pass Filter (External Sensor) (U4: B)
A1	PIC24HJ128GP504 (MCU) (U5)	A10	Sensor Differential Inputs (External Sensor) (TP11 and TP12)
A2	Speaker (SP2)	A11	Triaxial Analog Accelerometer (U8)

Legend:

D# = Debug components

A# = Audio components

4.3.1 Debug Components

The following components support the debug function of the starter kit. See **Appendix A. "Schematics"** for debug schematics.

4.3.1.1 MINI-B USB CONNECTOR (J1)

Provides system power and bidirectional communication between the host PC and starter kit.

4.3.1.2 MCP1727 (U1)

3.3V Linear regulator. Regulates the USB unregulated voltage to 3.3 volts (with respect to V_{SS}) and supplies the starter kit with system power.

4.3.1.3 LOW V_{CE} SATURATION PNP TRANSISTOR SWITCH (Q1)

Provides target power (via high-side switching) to the PIC24HJ128GP504 (and ancillary circuitry) via control by the PIC18F67J50 programming/debugging MCU.

4.3.1.4 DEBUG STATUS LED (D18)

When lit, indicates that communication between the starter kit and MPLAB IDE has been successfully established.

4.3.1.5 SYSTEM POWER STATUS LED (D19)

When lit, indicates that the starter kit is powered via the USB.

4.3.1.6 PIC18F67J50 MCU (U2)

Controls the programming/debugging operations of the target PIC24HJ128GP504 device.

4.3.1.7 25LC010A SERIAL EEPROM (U3)

Provides nonvolatile parameter storage for the PIC18F67J50 MCU.

4.3.2 Application Components

The following components support the application portion of the starter kit. See **Appendix A. "Schematics"** for application schematics.

4.3.2.1 PIC24HJ128GP504 (MCU) (U5)

The PIC24HJ128GP504 microcontroller unit (MCU) provides the computation and processing resource for application development on the starter kit. This MCU features 128 KB of program Flash and 4 KB RAM. The application can either use the on-chip FRC or the external 12 MHz signal as clock source.

4.3.2.2 SPEAKER (SP2)

The speaker is connected to the Output Compare (OC) module. The OC module produces the PWM-modulated speech signal that is played through the speaker after filtering.

4.3.2.3 AUDIO POWER AMPLIFIER (U7)

The audio power amplifier is a National Semiconductor, LM4853 Mono 1.5W/Stereo 300 mW amplifier. Gain has been set to 3.3 using the resistors R56 and R59, as shown in Equation 4-2.

EQUATION 4-2: AUDIO POWER AMPLIFIER GAIN

$$Gain = 2 \left(\frac{R56}{R59} \right)$$

4.3.2.4 ANTI-ALIASING LOW-PASS FILTER (SPEECH) (U6: A, B)

The PWM signal from the output compare module on the PIC24H MCU device on the board is demodulated by the PWM low-pass filter. This 4th-order filter uses two op amps (U6: A and U6: B) on the MCP617 dual op amp IC. The cut-off frequency of the filter is ~4 kHz.

4.3.2.5 OLED DISPLAY (LED)

The starter kit has a 128 x 64 pixel, monochrome organic LED array, which provides a wide range of graphics and alphanumeric display options.

4.3.2.6 SWITCH S1 AND SWITCH S2

The starter kit has two press switches, S1 and S2, which are connected to the I/O ports on the PIC24H MCU device. The functions of these two switches are defined by the application.

4.3.2.7 DIFFERENTIAL AMPLIFIER (EXTERNAL SENSOR) (U4: A)

The first op amp of the U4 component MCP617 is used to construct the differential amplifier circuit, which is used in the analog signal conditioning circuit for the external sensor.

4.3.2.8 ANTI-ALIASING LOW-PASS FILTER (EXTERNAL SENSOR) (U4: B)

The second op amp of the U4 component MCP617 is used to construct the anti-aliasing low-pass filter circuit, which follows the differential amplifier circuit in the analog signal conditioning circuit for the external sensor.

4.3.2.9 SENSOR DIFFERENTIAL INPUTS (EXTERNAL SENSOR) (TP11 AND TP12)

The interface holes, TP11 and TP12, can be used to connect the differential outputs of the external sensor. TP11 takes in the positive node and TP12 the negative node.

4.3.2.10 TRIAXIAL ANALOG ACCELEROMETER (U8)

The starter kit features a triaxial analog accelerometer, BMA140, from Bosch Sensortec.

NOTES:



MPLAB® STARTER KIT FOR PIC24H MICROCONTROLLERS USER'S GUIDE

Appendix A. Schematics

This appendix provides the following schematics for the MPLAB Starter Kit for PIC24H Microcontrollers:

Section A.1 “Application Schematics”:

- Figure A-1: Processor Schematic
- Figure A-2: Accelerometer Schematic
- Figure A-3: Speaker Schematic
- Figure A-4: Differential Amplifier and Low-Pass Filter Schematic
- Figure A-5: Organic LED (OLED) Display Schematic
- Figure A-6: User Switches and Test Points Schematics

Section A.2 “Debug Schematics”:

- Figure A-7: USB Interface/Target Power Switching and Debug Input and Control Schematics (Sheet 1 of 2)
- Figure A-8: USB Interface/Target Power Switching and Debug Input and Control Schematics (Sheet 2 of 2)

A.1 APPLICATION SCHEMATICS

FIGURE A-1: PROCESSOR SCHEMATIC

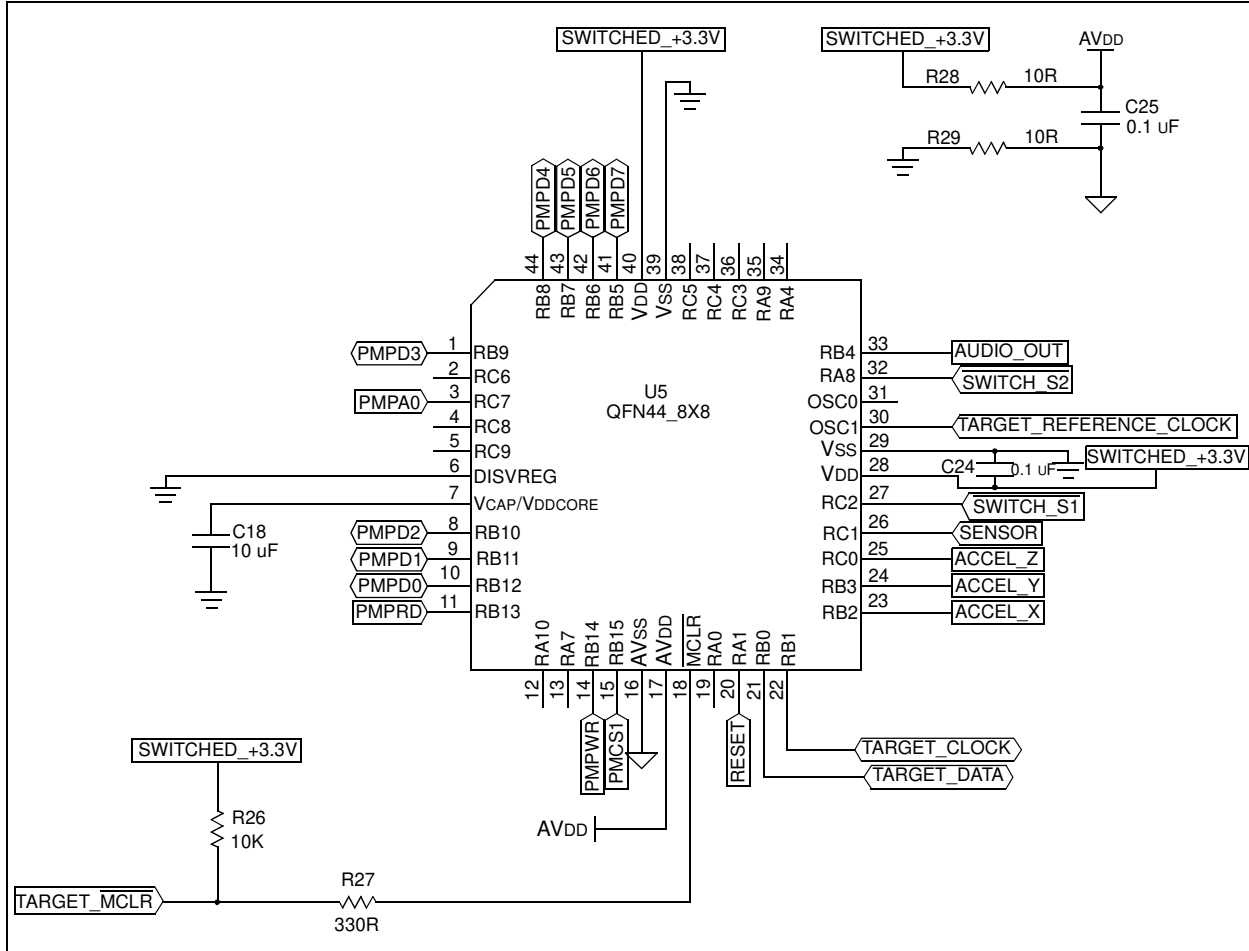

FIGURE A-2: ACCELEROMETER SCHEMATIC

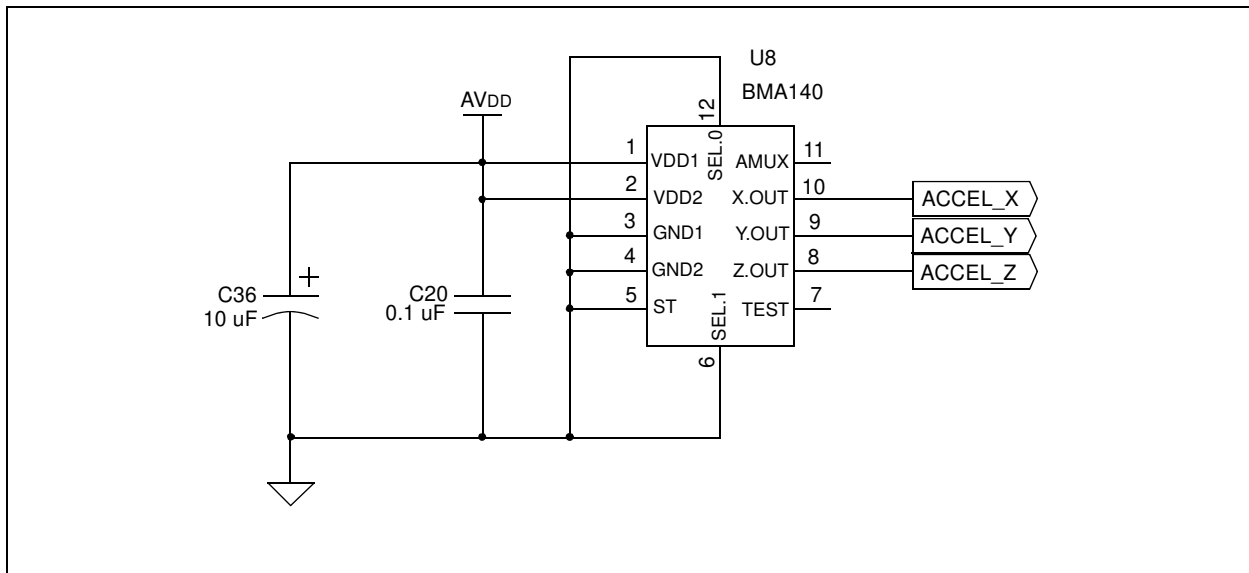

FIGURE A-3: SPEAKER SCHEMATIC

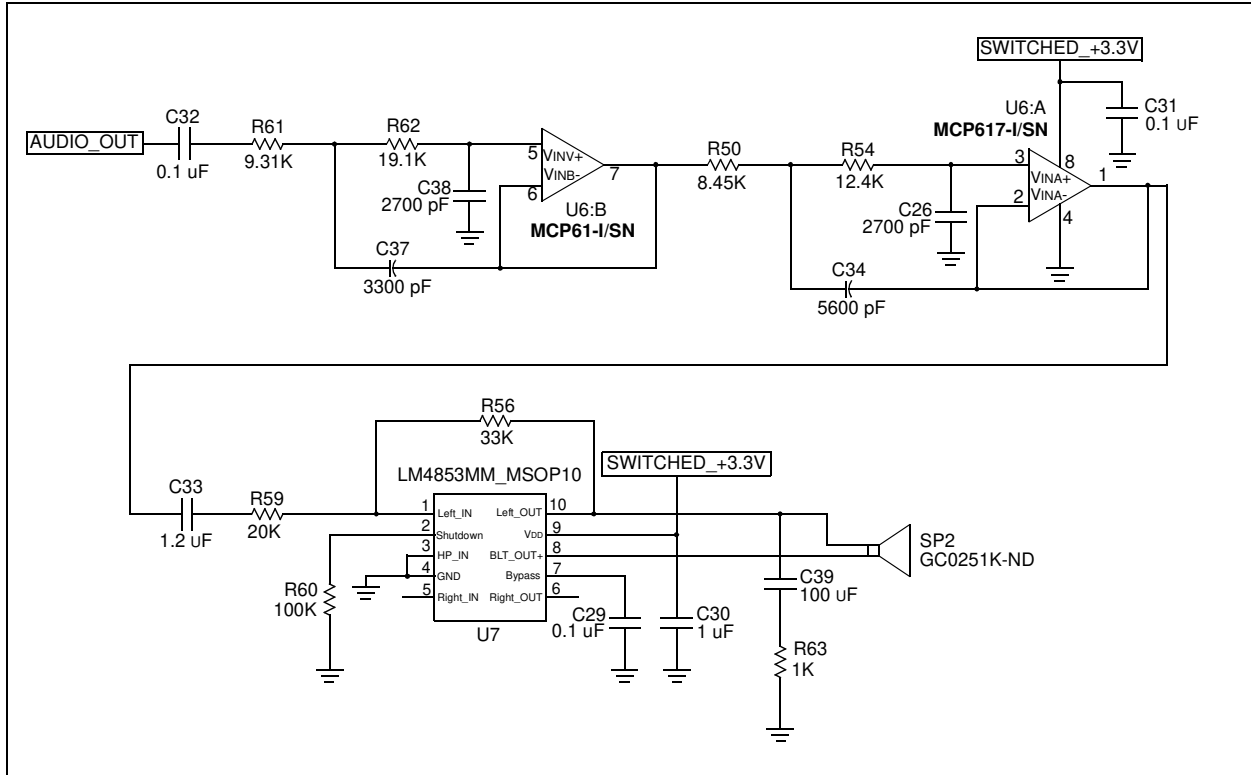

FIGURE A-4: DIFFERENTIAL AMPLIFIER AND LOW-PASS FILTER SCHEMATIC

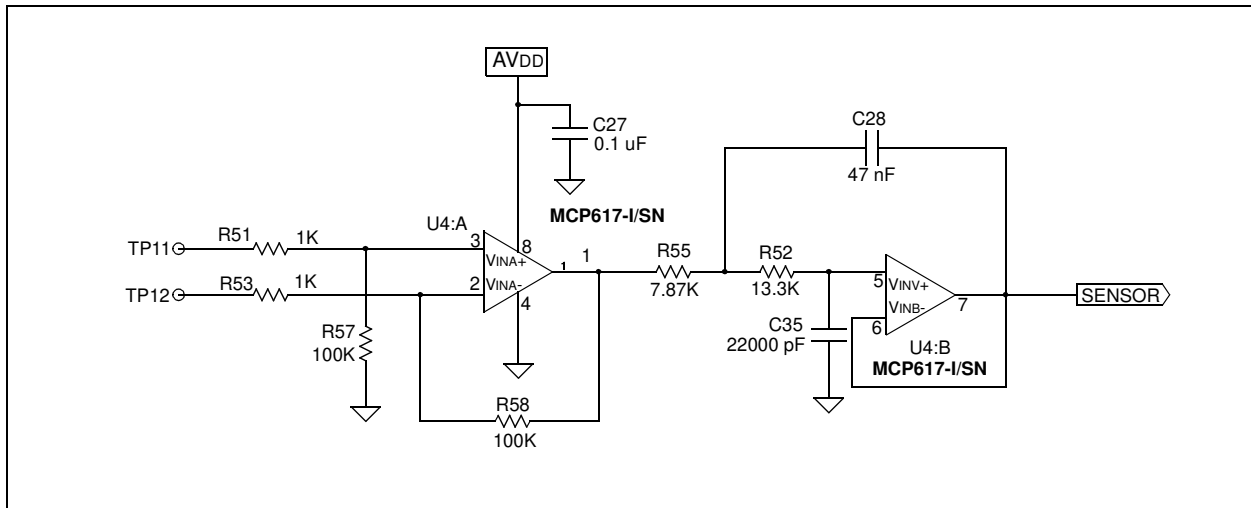

FIGURE A-5: ORGANIC LED (OLED) DISPLAY SCHEMATIC

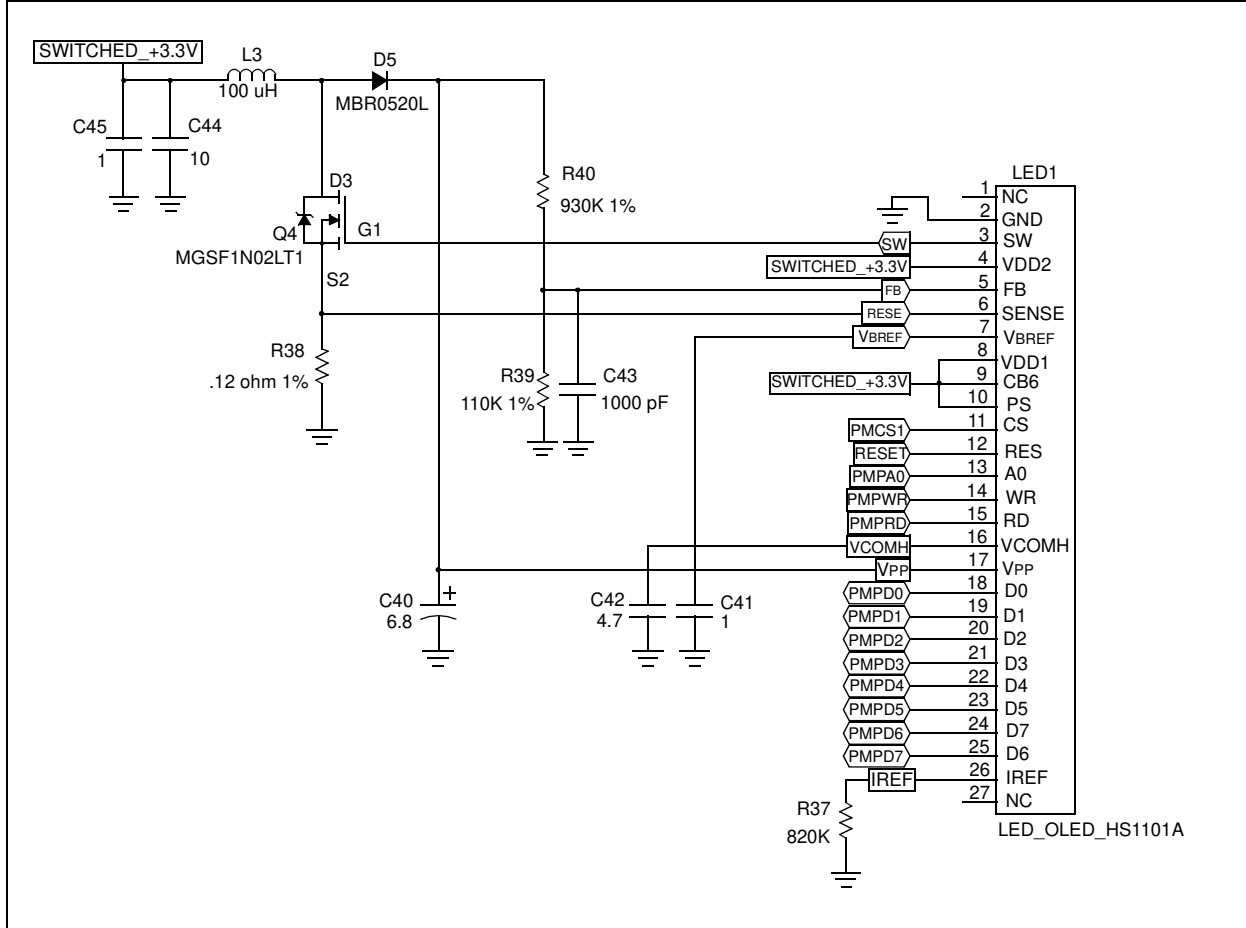
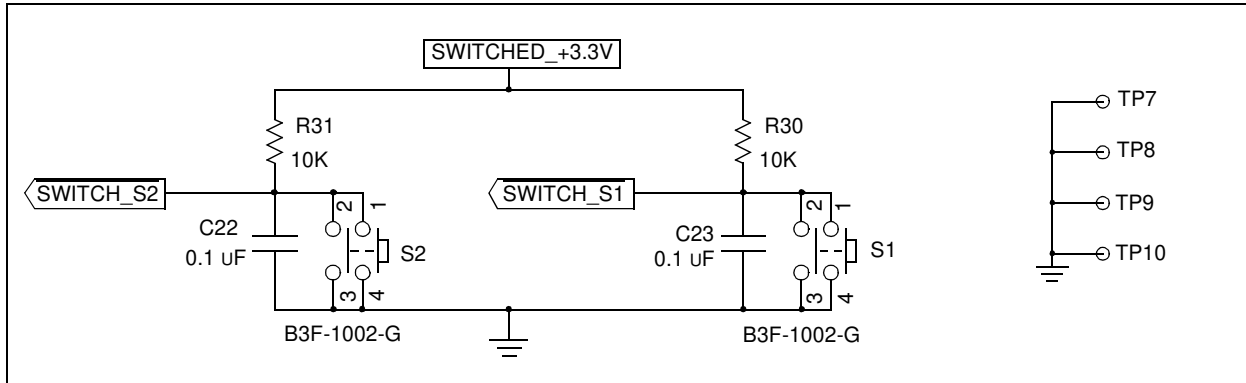

FIGURE A-6: USER SWITCHES AND TEST POINTS SCHEMATICS



A.2 DEBUG SCHEMATICS

FIGURE A-7: USB INTERFACE/TARGET POWER SWITCHING AND DEBUG INPUT AND CONTROL SCHEMATICS (SHEET 1 OF 2)

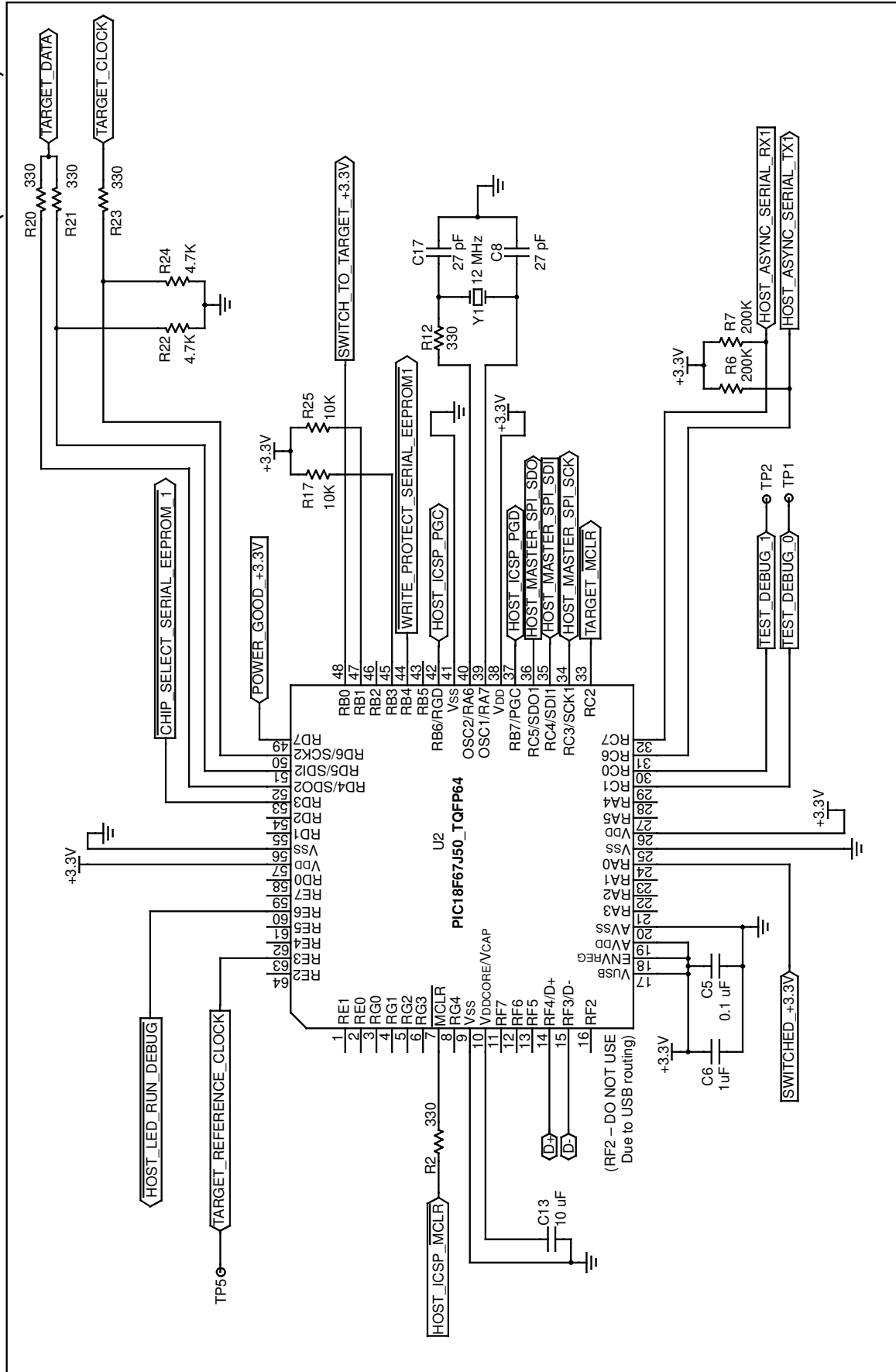
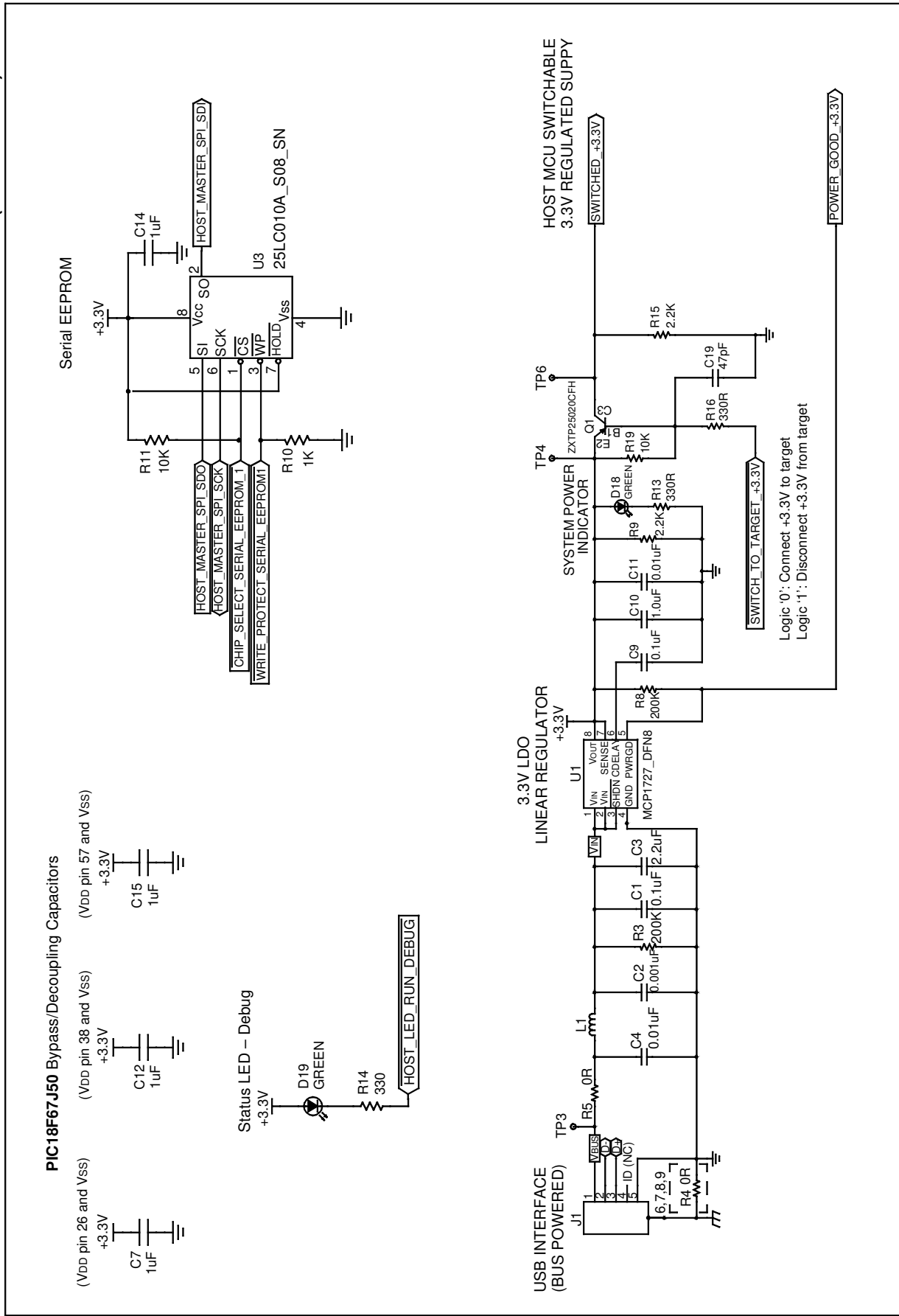

FIGURE A-8: USB INTERFACE/TARGET POWER SWITCHING AND DEBUG INPUT AND CONTROL SCHEMATICS (SHEET 2 OF 2)





MPLAB[®] STARTER KIT FOR PIC24H MICROCONTROLLERS USER'S GUIDE

Index

A		O	
Accelerometer Interface	14, 26	OLED Display Interface.....	14, 26
Amplifier Gain	27, 31	Operational Requirements	8
Analog Conditioning Circuitry.....	27	Overview	7
B		P	
Board Components	29	Programmer	22
Board Setup	8	R	
Breakpoints	19	Reading, Recommended	3
Build Configuration.....	23	Reserved Resources.....	22
C		Reset.....	19
Configuration Bits.....	23	Run.....	19
Customer Notification Service.....	4	S	
Customer Support.....	5	Schematics	
D		Application	
Debug	28	Accelerometer.....	34
Executive	18	Differential Amplifier and Low-Pass Filter..	35
Reserved Resources	22	Processor.....	34
Setup	18	Speaker	35
Debug/Release	23	User Switches and Test Points.....	36
Demo2	15	Debug	
Demonstration Application	9	USB Interface Schematic/Target	
Documentation		Power Switching Schematic	37, 38
Conventions.....	2	Setup.....	8
Layout	1	Software Installation.....	17
E		Speaker Interface	14, 26
External Sensor Interface	15	Speech Sampling Interface Schematic	38
H		Step.....	19
Halt.....	19	T	
Hardware Installation	17	Troubleshooting	23
Host Computer Requirements.....	8	U	
I		Unable to Enter Debug Mode.....	23
Install.....	17	W	
Internet Address.....	4	Warranty Registration	3
M		Watch Window	19
Microchip Internet Web Site.....	4	WWW Address.....	4
MPLAB IDE	17		



Worldwide Sales and Service

AMERICAS

Corporate Office
2355 West Chandler Blvd.
Chandler, AZ 85224-6199
Tel: 480-792-7200
Fax: 480-792-7277
Technical Support:
<http://support.microchip.com>
Web Address:
www.microchip.com

Atlanta
Duluth, GA
Tel: 678-957-9614
Fax: 678-957-1455

Boston
Westborough, MA
Tel: 774-760-0087
Fax: 774-760-0088

Chicago
Itasca, IL
Tel: 630-285-0071
Fax: 630-285-0075

Dallas
Addison, TX
Tel: 972-818-7423
Fax: 972-818-2924

Detroit
Farmington Hills, MI
Tel: 248-538-2250
Fax: 248-538-2260

Kokomo
Kokomo, IN
Tel: 765-864-8360
Fax: 765-864-8387

Los Angeles
Mission Viejo, CA
Tel: 949-462-9523
Fax: 949-462-9608

Santa Clara
Santa Clara, CA
Tel: 408-961-6444
Fax: 408-961-6445

Toronto
Mississauga, Ontario,
Canada
Tel: 905-673-0699
Fax: 905-673-6509

ASIA/PACIFIC

Asia Pacific Office
Suites 3707-14, 37th Floor
Tower 6, The Gateway
Harbour City, Kowloon
Hong Kong
Tel: 852-2401-1200
Fax: 852-2401-3431

Australia - Sydney
Tel: 61-2-9868-6733
Fax: 61-2-9868-6755

China - Beijing
Tel: 86-10-8528-2100
Fax: 86-10-8528-2104

China - Chengdu
Tel: 86-28-8665-5511
Fax: 86-28-8665-7889

China - Hong Kong SAR
Tel: 852-2401-1200
Fax: 852-2401-3431

China - Nanjing
Tel: 86-25-8473-2460
Fax: 86-25-8473-2470

China - Qingdao
Tel: 86-532-8502-7355
Fax: 86-532-8502-7205

China - Shanghai
Tel: 86-21-5407-5533
Fax: 86-21-5407-5066

China - Shenyang
Tel: 86-24-2334-2829
Fax: 86-24-2334-2393

China - Shenzhen
Tel: 86-755-8203-2660
Fax: 86-755-8203-1760

China - Wuhan
Tel: 86-27-5980-5300
Fax: 86-27-5980-5118

China - Xiamen
Tel: 86-592-2388138
Fax: 86-592-2388130

China - Xian
Tel: 86-29-8833-7252
Fax: 86-29-8833-7256

China - Zhuhai
Tel: 86-756-3210040
Fax: 86-756-3210049

ASIA/PACIFIC

India - Bangalore
Tel: 91-80-4182-8400
Fax: 91-80-4182-8422

India - New Delhi
Tel: 91-11-4160-8631
Fax: 91-11-4160-8632

India - Pune
Tel: 91-20-2566-1512
Fax: 91-20-2566-1513

Japan - Yokohama
Tel: 81-45-471- 6166
Fax: 81-45-471-6122

Korea - Daegu
Tel: 82-53-744-4301
Fax: 82-53-744-4302

Korea - Seoul
Tel: 82-2-554-7200
Fax: 82-2-558-5932 or
82-2-558-5934

Malaysia - Kuala Lumpur
Tel: 60-3-6201-9857
Fax: 60-3-6201-9859

Malaysia - Penang
Tel: 60-4-227-8870
Fax: 60-4-227-4068

Philippines - Manila
Tel: 63-2-634-9065
Fax: 63-2-634-9069

Singapore
Tel: 65-6334-8870
Fax: 65-6334-8850

Taiwan - Hsin Chu
Tel: 886-3-572-9526
Fax: 886-3-572-6459

Taiwan - Kaohsiung
Tel: 886-7-536-4818
Fax: 886-7-536-4803

Taiwan - Taipei
Tel: 886-2-2500-6610
Fax: 886-2-2508-0102

Thailand - Bangkok
Tel: 66-2-694-1351
Fax: 66-2-694-1350

EUROPE

Austria - Wels
Tel: 43-7242-2244-39
Fax: 43-7242-2244-393

Denmark - Copenhagen
Tel: 45-4450-2828
Fax: 45-4485-2829

France - Paris
Tel: 33-1-69-53-63-20
Fax: 33-1-69-30-90-79

Germany - Munich
Tel: 49-89-627-144-0
Fax: 49-89-627-144-44

Italy - Milan
Tel: 39-0331-742611
Fax: 39-0331-466781

Netherlands - Drunen
Tel: 31-416-690399
Fax: 31-416-690340

Spain - Madrid
Tel: 34-91-708-08-90
Fax: 34-91-708-08-91

UK - Wokingham
Tel: 44-118-921-5869
Fax: 44-118-921-5820