

BACKPLANE HOLE PATTERN (COMPONENT SIDE)

LEAD-FREE PLATING

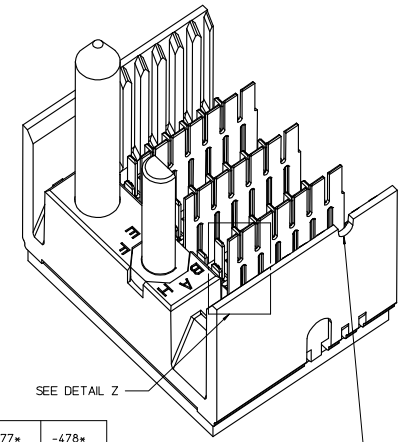
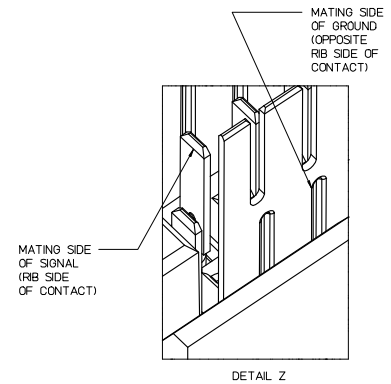

NOTCH DESIGNATES APPROXIMATE LOCATION OF PIN A1, ARCH & NOTCH ON OPPOSITE SIDE OF PART MARKING

- NOTES:
1. MATERIAL: HOUSING - LIQUID CRYSTAL POLYMER (LCP) GLASS-FILLED, UL 94V-0, COLOR - GRAY. SIGNAL CONTACT AND GROUND BLADE - HIGH PERFORMANCE COPPER ALLOY.
 2. FINISHES: SELECTIVE GOLD (Au) ON CONTACT AREA, SELECTIVE MATTE TIN (Sn) ON PCB TAILS, NICKEL (Ni) OVERALL.
 3. THIS PART CONFORMS TO MOLEX PRODUCT SPECIFICATION PS-75221-999.
 4. FOR MIXED CONTACT MATING LENGTHS CONSULT MOLEX FOR AVAILABILITY. CONTACT PAIRS MUST BE THE SAME LENGTH.
 5. FOR SPECIFIC PART NUMBER AND MATING INFORMATION PLEASE REFER TO CHART.
 6. PACKAGE PER PK-70873-563.
 7. MARK PART NUMBER AND DATE CODE APPROXIMATELY WHERE SHOWN.
 8. OPTIONAL HOLE LOCATION FOR GROUNDED GUIDE PIN OR ADDITIONAL GUIDE PIN SUPPORT. FOR GROUNDED GUIDE PIN, HOLE TO BE PLATED, DRILL SIZE Ø2.58, PAD SIZE Ø5.50
 9. THIS PART CONFORMS TO MOLEX COSMETIC SPECIFICATION PS-45499-002 CLASS B.
 10. MAPS (MOLEX ADVANCED PLATING SYSTEM).

THE PRIMARY CARTON WITH A LABEL STATING "ELV AND RoHS COMPLAINT" IS LEAD FREE. CARTONS WITHOUT THIS LABEL MAY CONTAIN LEAD.

P/N	-470*	-471*	-472*	-473*	-474*	-475*	-476*	-477*	-478*
75235(-)	0	A	B	C	D	E	F	G	H
KEYING PIN ORIENTATION									

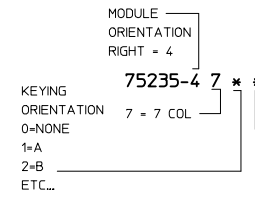

PIN LENGTH DIM "M"	GOLD (Au) THICKNESS micrometers
0-3.55 mm	
1-4.55 mm	0.25 (MAPS)
2-5.55 mm	
3-3.55 mm	0.76
4-4.55 mm	
5-5.55 mm	
7-3.55 mm	1.27
8-4.55 mm	
9-5.55 mm	

REV TO LEAD-FREE EEC NO: UCP2013-0690 DRWNGES 2012/09/06 CHYKMOLEFE 2012/09/06 APPR:SMILLER 2012/12/05	QUALITY SYMBOLS ∇=0 ∇=0 ∇=0	GENERAL TOLERANCES (UNLESS SPECIFIED) 4 PLACES ±--- INCH 3 PLACES ±--- INCH 2 PLACES ±0.25 INCH 1 PLACE ±0.38 INCH 0 PLACE ±--- INCH ANGULAR ±1/2° DRAFT WHERE APPLICABLE MUST REMAIN WITHIN DIMENSIONS	DIMENSION STYLE MM ONLY	SCALE 5:1	DESIGN UNITS METRIC	THIRD ANGLE PROJECTION
			DRAWN BY JB INGHAM DATE 2006/11/30	CHECKED BY SREED DATE 2006/11/30	APPROVED BY SMILLER DATE 2012/12/05	MATERIAL NO. SEE CHART

THIS DRAWING CONTAINS INFORMATION THAT IS PROPRIETARY TO MOLEX INCORPORATED AND SHOULD NOT BE USED WITHOUT WRITTEN PERMISSION