

SPC472 O-ring (gasket) for Panel Mount Indicator

O-ring (gasket) designed to seal against water, oil, air and dust.
For 1050, 1052, 1090, 1091 and 1092 Series

Applications

- Humid or dusty environments
- When there is presence of grease, fluid, water or dirt

Key Features

- The panel gasket is intended to provide a seal between the panel and the Panel Mount Indicator.
- Molded in one piece from an elastomeric (rubber-like) material.
- Designed to seal many types of media, including water, air, dust, and oil.
- Meets ASTM D2000 standard.

Product Dimensions

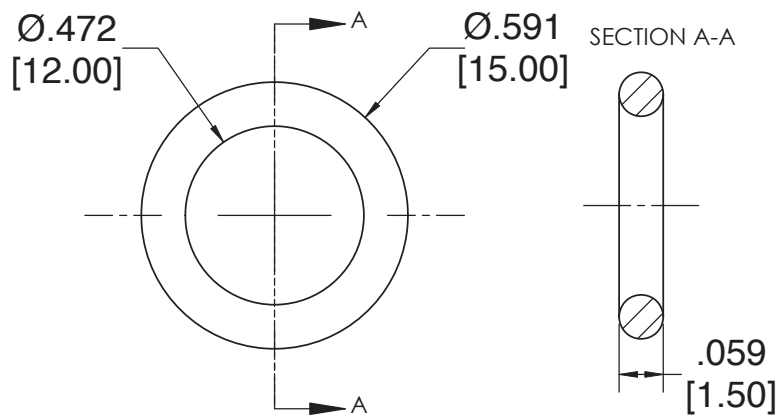

Dimensions in inches [mm]

Ordering Data

Part Number **SPC472**



SPC472



Examples: SPC472 in Panel Mount Indicators

Product Specifications

Material
Buna-N, Durometer A50, black

Installation Specification	
Internal Diameter	0.472" (12 mm)
Thickness	0.059" (1.5 mm)
Operational Temperature	-30°F to +225°F -34.4°C to +107.2°C

Compliances and Approvals

