

**NOTES:**  
 1. CARD SLOT ACCEPTS P.C. BOARDS  $.050 +.004/-0.003$  THICK, MEASURED OVER CONTACT PADS. (1.27 +0.10/-0.08)  
 2. LOCATION OF LOWER CORNER OF MODULE BOARD.  
 3. PRODUCT SPEC PS-78954 APPLIES.  
 4. CENTER PEG IS AN INTERFERENCE FIT TO RECOMMENDED P.C. BOARD HOLE.

**MATERIALS:**  
 HOUSING: LCP, GLASS FILLED, 94V-0. COLOR: BLACK.  
 LATCH: STAINLESS STEEL.  
 TERMINAL: PHOSPHOR BRONZE, POST PLATED  
 30  $\mu$ m/(0.76  $\mu$ m) MINIMUM GOLD IN CONTACT AREA AND  
 150  $\mu$ m/(3.81  $\mu$ m) MINIMUM TIN IN TAIL AREA OVER  
 75  $\mu$ m/(1.91  $\mu$ m) MINIMUM NICKEL OVERALL.

THE PRIMARY SHIPPING CARTON WILL BE LABELED "COMPLIANT TO ROHS DIRECTIVE 2002/95/EC AND ELV ANNEX II OF DIRECTIVE 2000/53/EC". CARTONS WITHOUT THIS LABEL MAY CONTAIN PRODUCT WITH LEAD.

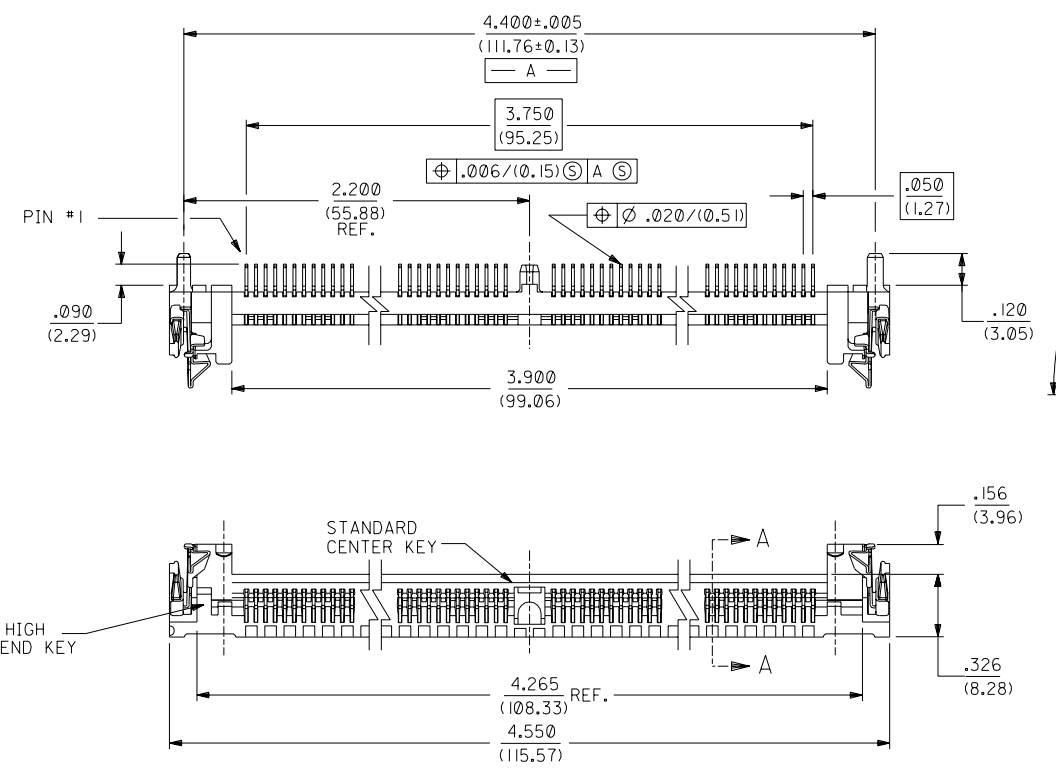
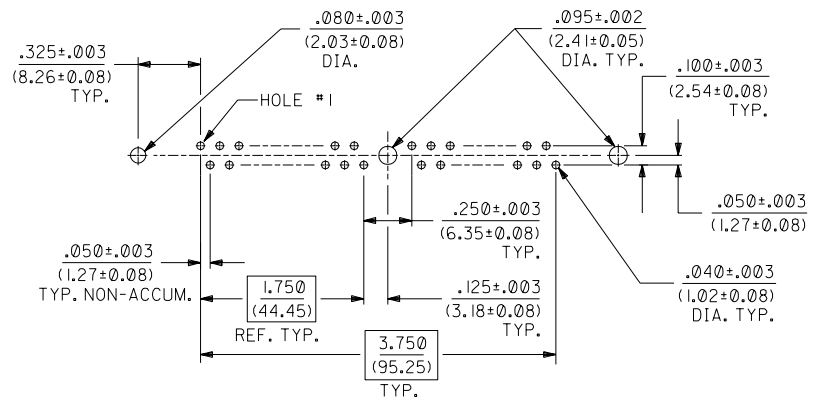

RECOMMENDED SOCKET P.C. BOARD HOLE PATTERN

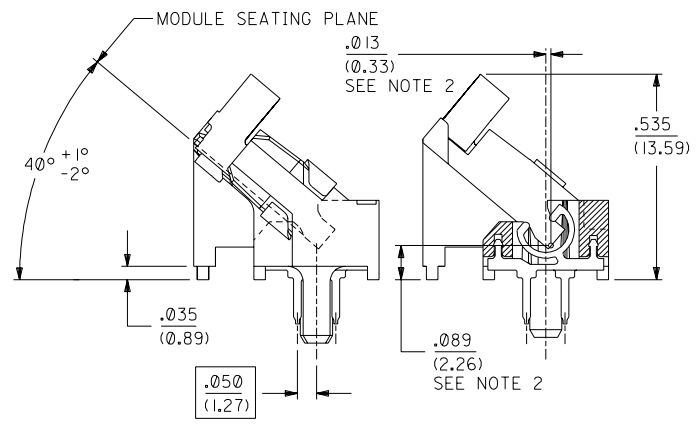

END VIEW SCALE 4:1 SECTION A-A SCALE 4:1

K	LEAD FREE UCP 2004 1582 RWHITE 04/03/03
J	REVISED PER ECN # U51393 CMY 7-25-95
II	CORRECTED TEXT PER ECN # U50199 MJS 10-6-94
I	.050 BASIC TAIL DIM. PER ECN # U30092 PDB 01-21-93
H	.010 BLOCK TOL WAS .050 PER ECN # U21290 PDB 08-27-92
G	REMOVE TRACKING TOES PER ECN # U20978 PDB 06-29-92
F	REVISED GEOMETRY PER ECN # U20157 PDB 02-10-92
E	CORRECT HOLE PATTERN PER ECN # U11932 PDB 09-25-91
D	REVISED SALES MASTER PER ECN # U1129 PDB 06-26-91
C	REVISED PER ECN # U00860 PDB 11-06-90
B	REVISED PER ECN # U00635 PDB 08-20-90
A	RELEASE TO MFG. PER ERO # 30214 PDB 07-30-90

DIMENSIONS SHOWN (METRIC) INCH UNLESS OTHERWISE SPECIFIED TOLERANCES: ANGULAR ± 1/2°		▽ = 0 ▽ = 0 REVISE ONLY ON CAD SYSTEM	
3 PLACE ± .010	---	TITLE SALES ASSY. 72 CIRCUIT 40° METAL LATCH HIGH KEY SINGLE ROW SIMM SOCKET	
2 PLACE ± .014 ± 0.25	---	MOLEX INCORPORATED SHEET NO. DATE 1 OF 1 07/30/90	
1 PLACE --- ± 0.36	---	PART NO. DRWG. NO. 15-82-0627 SDA-78976-7232	
DRAFT WHERE APPLICABLE MUST REMAIN WITHIN DIMENSIONS		FILE NAME DIV. SIZE 57897605 DA C	
DRWG. PDB	CHK'D. BY	THIS DRAWING CONTAINS INFORMATION THAT IS PROPRIETARY TO MOLEX INC. AND SHOULD NOT BE USED WITHOUT WRITTEN PERMISSION	
APP'D. BY	SCALE 2:1		

DWG. NO.  
SDA-78976-7232

DIMENSIONS IN METRIC DO NOT SCALE DRAWING

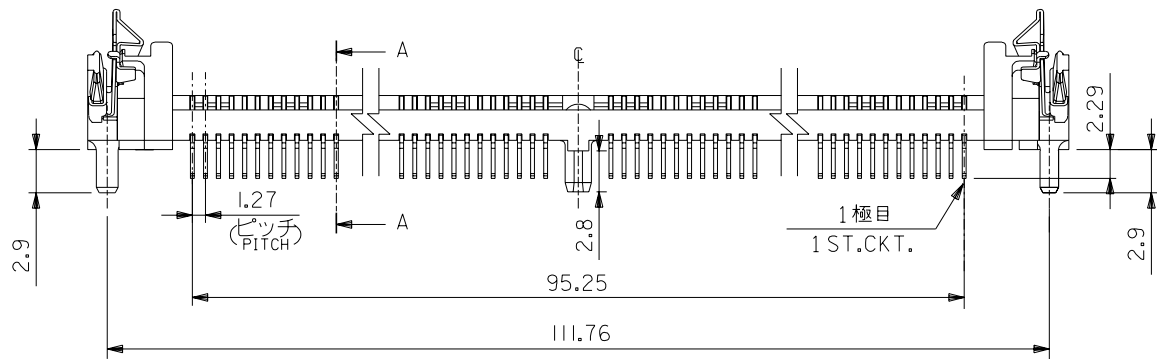
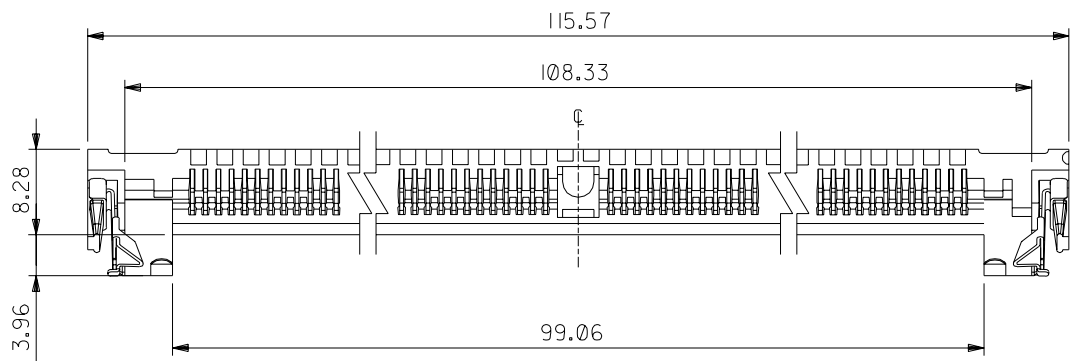

注記 NOTES.

1. 材料 MATERIAL  
 1-1 ハウジング: ガラス入り耐熱樹脂 色:黒 UL94V-0  
 HOUSING : G.F.HEAT RESISTANT PLASTIC  
 COLOR:BLACK UL94V-0  
 1-2 ターミナル: 燐青銅  
 TERMINAL : PHOSPHOR BRONZE  
 1-3 ラッチ : パネ用ステンレス鋼  
 LATCH : STAINLESS SPRING STEEL

2. メッキ仕様 (ターミナル)  
 PLATING(TERMINAL)  
 接点部 : 金メッキ 0.76μm MIN.  
 CONTACT AREA:GOLD 0.76 MICROMETER MINIMUM  
 半田付け部: 錫メッキ 3.81μm MIN.  
 SOLDER TAIL AREA:TIN 3.81 MICROMETER MINIMUM  
 下地メッキ: ニッケルメッキ 1.91μm MIN.  
 UNDER-PLATING:NICKEL 1.91 MICROMETER MINIMUM

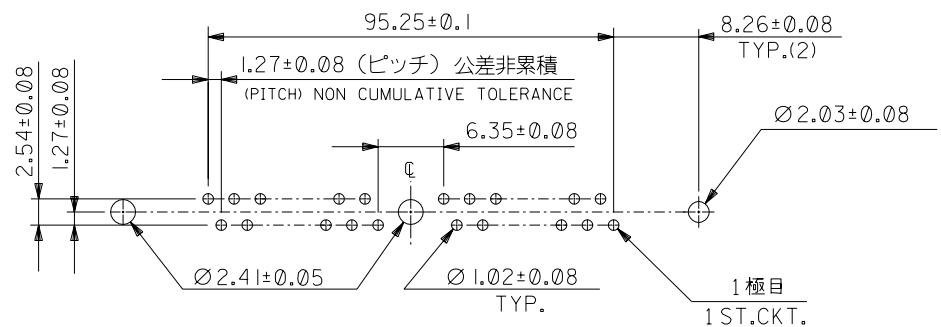
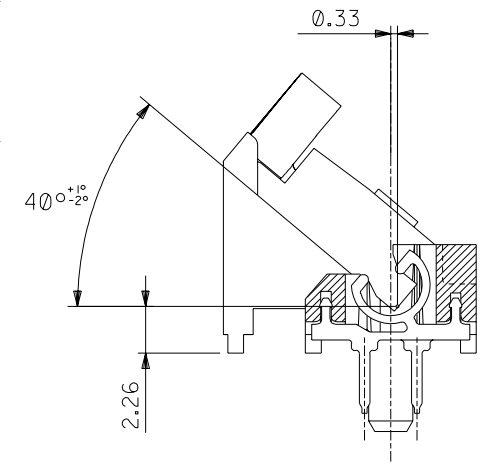
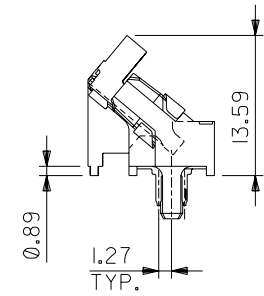

基板取付穴推奨寸法  
RECOMMENDED PCB LAYOUT  
(部品実装側)  
VIEW ON COMPONENT SIDE

角度 ANGLE	±3°
30°以上 OVER	+0.3
10°以上 30° UNDER	+0.25
未滿 10° UNDER	+0.2
一般公差 GENERAL TOLERANCES	

記号 LTR	変更内容 REVISION RECORD	DR. CHK.	日付 DATE
0	新規作成 (T30578)	S.M.S.	93/11/25
A	変更 (J2004-4492)	S.M.S.	04/05/31

材料 MATERIAL	注記参照 SEE NOTES
仕上げ FINISH	注記参照 SEE NOTES
適用電線範囲 WIRE RANGE	—
被覆外径 INS. RANGE	—
DRAWN BY	CHK'D BY
APP'D BY	尺度 SCALE 2-1

78976-7232	72
MATERIAL NO. 製品番号	CIRCUIT 極数
molex MOLEX-JAPAN CO.,LTD. 日本モレックス株式会社	
REVISE ONLY ON CAD SYSTEM	
TITLE 名称 40 DEG. SIMM SOCKET 72 CIRCUIT W/METAL LATCH -LEAD FREE-	
DWG. NO. SDA-78976-7232	REV A