

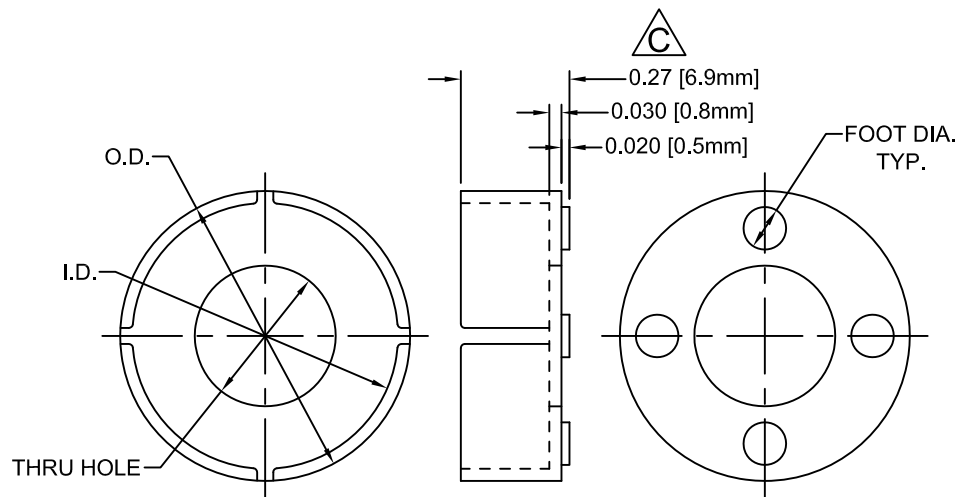

REV.	DESCRIPTION	DATE	APPROVED
B	Engineering Update w/o Changes	02/26/04	M. C.
C	Changed Dim. "0.275" to "0.27"	01/31/05	M. C.
D	Removed P/N ECM-2	07/16/14	J. C.
E	Removed Part From Part Offering List	09/29/15	J. C.



PART NO.	EC TYPE	I.D.	O.D.	THRU HOLE	FOOT DIA.
ECM-1	5	.227 (5.8mm)	.287 (7.3mm)	.125 (3.2mm)	.060 (1.5mm)
ECM-4	10	.424 (10.8mm)	.484 (12.3mm)	.250 (6.4mm)	.100 (2.5mm)
ECM-5	12.5-13	.542 (13.8mm)	.602 (15.3mm)	.350 (8.9mm)	.105 (2.7mm)
ECM-10	25	1.008 (25.6mm)	1.074 (27.3mm)	.547 (13.9mm)	.138 (3.5mm)
ECM-12	30	1.210 (30.5mm)	1.270 (32.3mm)	.645 (16.4mm)	.138 (3.5mm)
ECM-13	35	1.410 (35.8mm)	1.470 (37.3mm)	.645 (16.4mm)	.138 (3.5mm)

2. MATERIAL: NYLON 6/6, 94V-2, NATURAL. BIVAR MATERIAL CODE 03-NL.
 BASF ULTRAMID NYLON 6/6 A3K NATURAL.

1. GENERAL SPECIFICATIONS: BIVAR MOLDED COMPONENT SPECIFICATION BV00-E101.

STANDARD TOLERANCE (UNLESS OTHERWISE SPECIFIED)		 4 THOMAS, IRVINE, CA. 92618 TEL: (949) 951-8808 FAX: (949) 951-3974			
DECIMALS	ANGULAR				
.X ± .1	X° ± 1°	TITLE: ELECTROLYTIC CAPACITOR MOUNT			
.XX ± .01					
.XXX ± .005		DESIGNED: Shane Irving	DATE: 08/27/98	PART NO: ECM-XX	REVISION: E
		CHECKED: M. Chen	DATE: 03/04/03	CAGE CODE : 32559	SHEET # 1 OF 1
CAD GENERATED DOCUMENT, DO NOT MEASURE DRAWING.					