

NOTES:

1. DUST CAPS TO BE FITTED TO CONNECTORS. CABLE ASSEMBLY TO BE PACKED IN A PROTECTIVE BAG MARKED WITH A MINIMUM OF THE PART NUMBER, BATCH NUMBER, DATE CODE AND ITEM DESCRIPTION.

2. MC801 PART NUMBER EXAMPLE: H****D MC8010 -N -11-02 P N F064

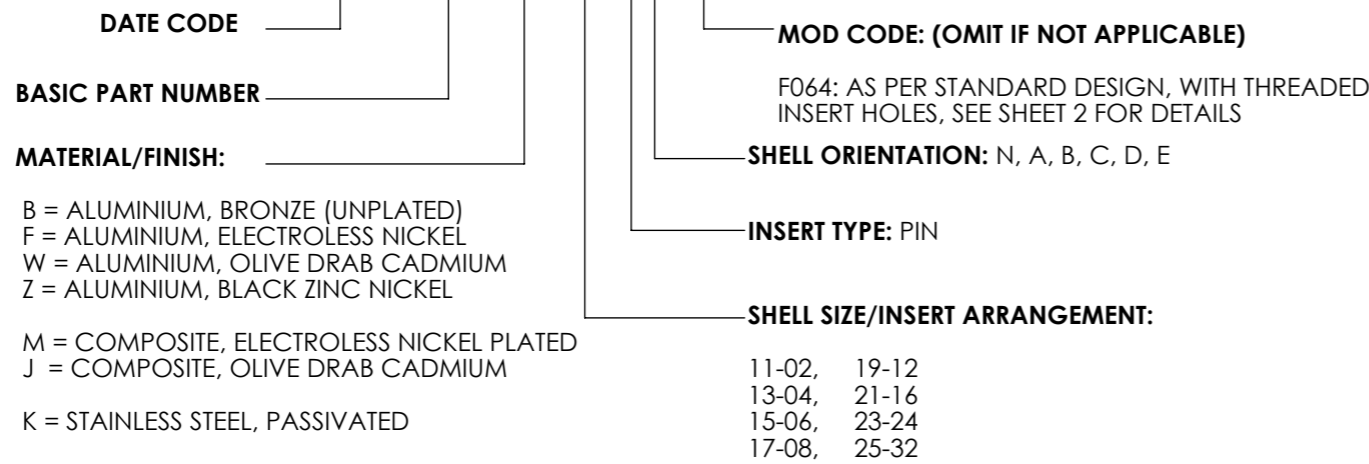

SHELL SIZE	INSERT ARRANGEMENT	A SQ ±0.3	B THREAD STUB 60° 1P-3L CLASS 2A (INCHES)	Ø THREAD C	D ±0.2	E	F	G ±0.2	H MAX	J MAX
11	2	26.2	0.7500	M15X1.0	3.25	20.62	18.26	4.93	20.90	3.65
13	4	28.6	0.8750	M18X1.0		23.01	20.62			
15	6	31.0	1.0000	M22X1.0		24.61	23.01			
17	8	33.3	1.1875	M25X1.0		26.97	24.61			
19	12	36.5	1.2500	M28X1.0		29.36	26.97			
21	16	39.7	1.3750	M31X1.0	31.75	29.36	6.15	20.10	4.35	
23	24	42.9	1.5000	M34X1.0	34.93	31.75				
25	32	46.0	1.6250	M37X1.0	38.10	34.93				

THIRD ANGLE PROJECTION	MATERIAL:		FINISH:		<p>DEUTSCH</p> <p>TE CONNECTIVITY UK LTD., ST. LEONARDS-ON-SEA, TN38 9RF, UK.</p>
	TITLE: ARINC 801, TYPE 1 RECEPTACLE				
UNLESS OTHERWISE STATED: DIMENSIONS: mm [INCHES]		TYPE: CUSTOMER DRAWING			
IF IN DOUBT, ASK		SIZE: A3	SCALE: 2:1	DRAWING NUMBER: 460074-ENV	SHEET: 1 OF 2
				ISSUE: AC	

AC	DUK-71779	AAS	MJH	MJH	CP	14/07/2020
ISSUE	CHANGE NOTE	DRAWN	CHECKED	APP. ENG.	APP. MARKETING	DATE

THIS INFORMATION IS CONFIDENTIAL AND PROPRIETARY TO TYCO ELECTRONICS CORPORATION AND ITS WORLDWIDE SUBSIDIARIES AND AFFILIATES (TE). IT MAY NOT BE DISCLOSED TO ANYONE OTHER THAN TE PERSONNEL, WITHOUT AUTHORIZATION FROM TE (www.te.com).

DRAWING NUMBER:
460074-ENV

MODIFICATION CODE F064:

ALL DIMENSIONS AS PER STANDARD CONNECTOR WITH THE EXCEPTION OF MODIFICATION AS DETAILED BELOW

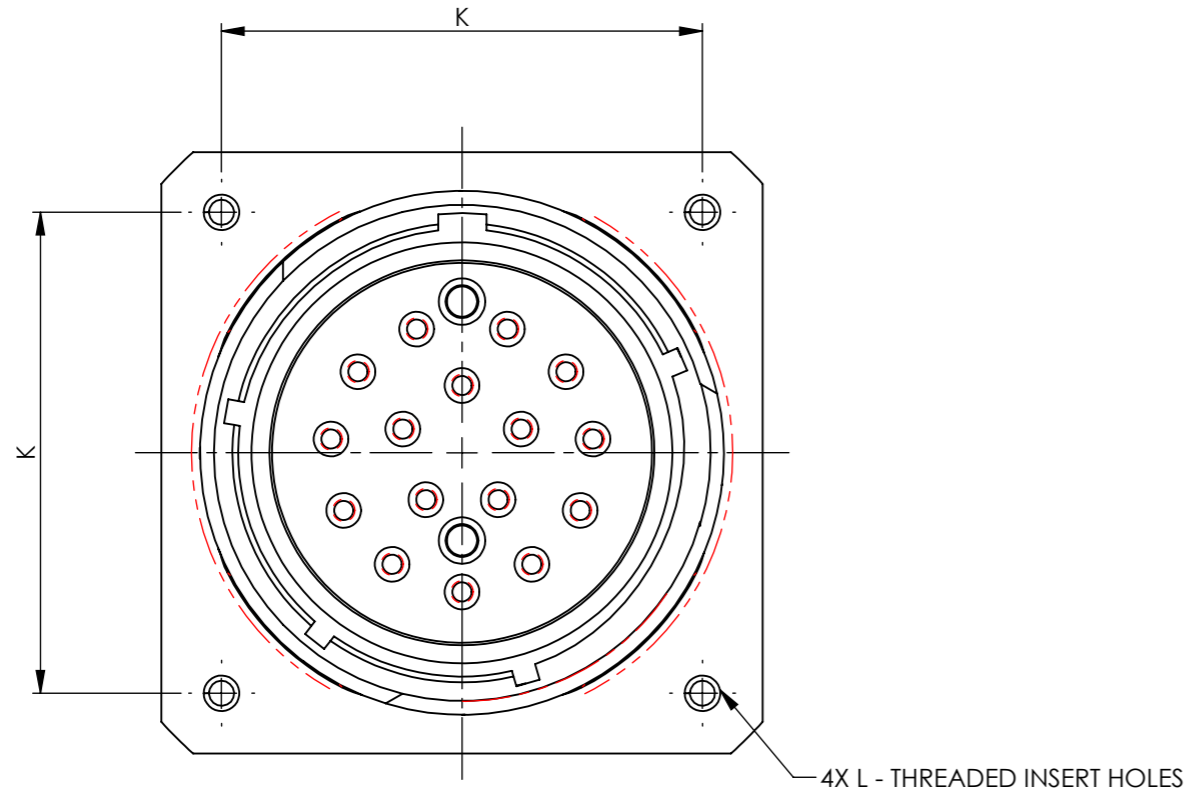

SHELL SIZE	K	L THREADED INSERT HOLE
11	20.6	0.112-40 UNC-2B
13	23.0	
15	24.6	
17	27.0	
19	29.4	
21	31.8	0.138-32 UNC-2B
23	34.9	
25	38.1	

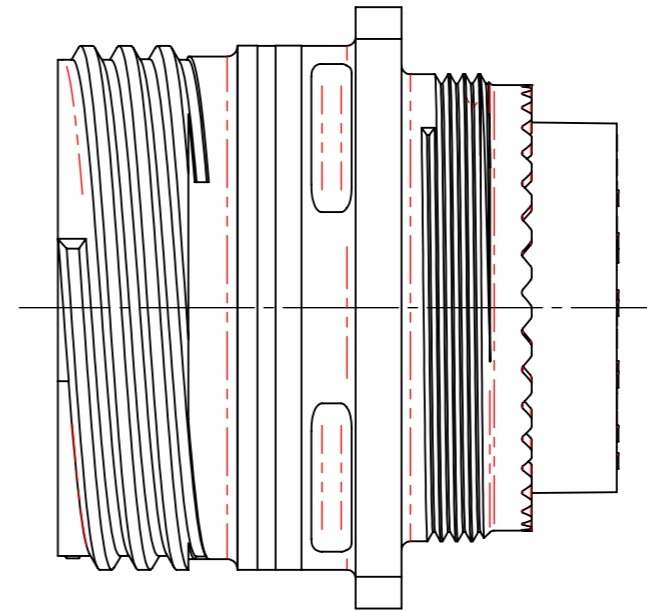
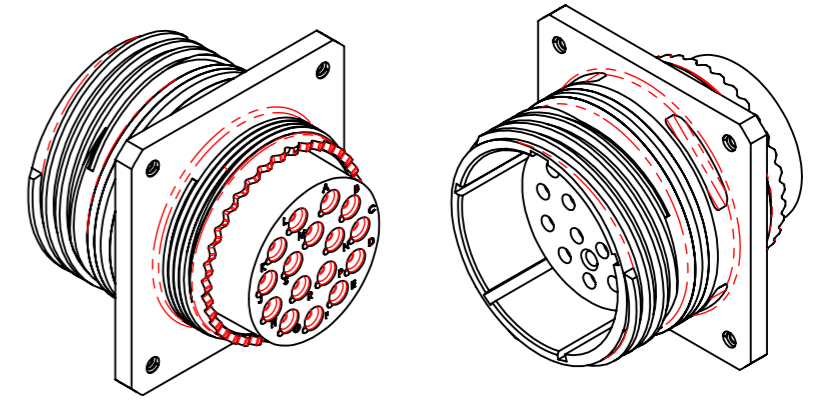

THIS INFORMATION IS CONFIDENTIAL AND PROPRIETARY TO TYCO ELECTRONICS CORPORATION AND ITS WORLDWIDE SUBSIDIARIES AND AFFILIATES (TE). IT MAY NOT BE DISCLOSED TO ANYONE OTHER THAN TE PERSONNEL, WITHOUT AUTHORIZATION FROM TE (www.te.com).

BS8888 THIRD ANGLE PROJECTION	MATERIAL:	FINISH:	 DEUTSCH TE CONNECTIVITY UK LTD., ST. LEONARDS-ON-SEA, TN38 9RF, UK.	
	TITLE: ARINC 801, TYPE 1 RECEPTACLE TYPE: CUSTOMER DRAWING			
UNLESS OTHERWISE STATED: DIMENSIONS: mm [INCHES]	SIZE: A3	SCALE: 2:1	DRAWING NUMBER: 460074-ENV	SHEET: 2 OF 2 ISSUE: AC