



Electrical specifications

Center Frequency: 1500MHz
Insertion Loss @ fc: <3dB
Return Loss @ fc: >14dB
Rejection: >10dB @ 100kHz
>30dB @ 1-10 MHz

Mechanical

Connector Type: BNC (F)
Mounting Method: Threaded Mounting Holes
Dimensions: 2.5 x 1.5 x 0.750 Inches

Environmental

Storage Temperature: -55C to +95C
Operating Temperature: -45C to +85C
Shock: 20 G. 11ms
Vibration: 20 G. 5 to 200 MHz

Outline Drawing:

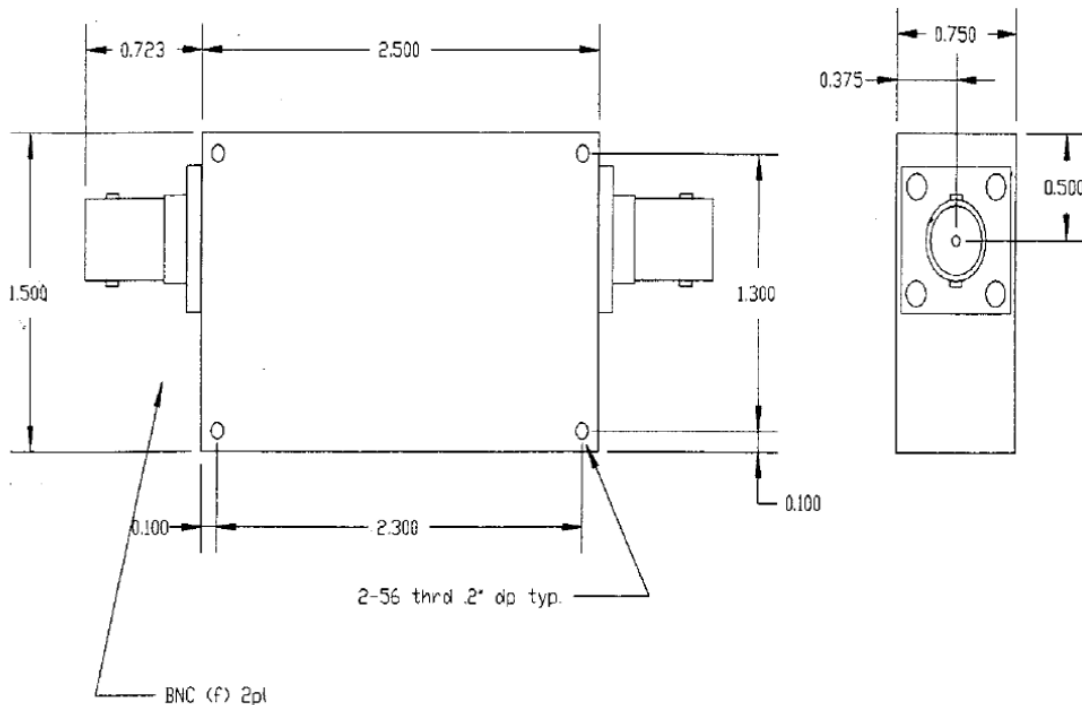



Response Plot:

