

**SPECIFICATION
FOR
LCD Module**

Customer P/N:

Santek P/N: ST0154G4W-RSLW-C

DOC. Revision: RS01

Customer Approval:

--

	SIGNATURE	DATE
PREPARED BY	Zhiyi Liao	2017-02-23
CHECKED BY	Sam Liu	2017-02-23
APPROVED BY	Natty Lee	2017-Feb-23

Document Revision History

Version	Revise Date	Description	Changed by
RS01	2017-02-23	First issue	Zhiyi Liao

Santek - CONFIDENTIAL

Table of Contents

1.	GENERAL DESCRIPTION	4
2.	MECHANICAL SPECIFICATIONS	4
3.	INTERFACE SIGNALS	6
4.	ABSOLUTE MAXIMUM RATINGS	6
5.	ELECTRICAL SPECIFICATIONS	7
6.	OPTICAL CHARACTERISTICS	8
7.	DATE INPUT CHARACTERISTICS	10
8.	ENVIRONMENTAL/RELIABILITY TEST	12
9.	INSPECTION CRITERIA	13
10.	SUGGESTIONS FOR USING LCD MODULES	19
11.	PACKING SPECIFICATION(REFERENCE ONLY)	26

1. General Description

- 1.54 " inch, 240 (RGB)x 240pixels, 262K colors, Transmissive, TFT LCD module.
- Viewing Direction: ALL Viewing
- Driving IC: ST7789
- MCU(8/9BIT) interface
- Power Supply voltage: 3.0-3.6V (typ.).
- Without touch panel.

2. Mechanical Specifications

The mechanical detail is shown in Fig. 1 and summarized in Table 1 below.

Table 1

Parameter	Specifications	Unit
Outline dimensions	31.5(W) x35.0(H) x1.52(D)	mm
active area	27.72(W) x 27.72(H)	
	Display format	240 (RGB)x240 pixels
	Color configuration	RGB stripes -
	Dot pitch	0.1155(W) x 0.1155(H) mm
Weight	TBD	grams

Figure 1: Outline Drawing

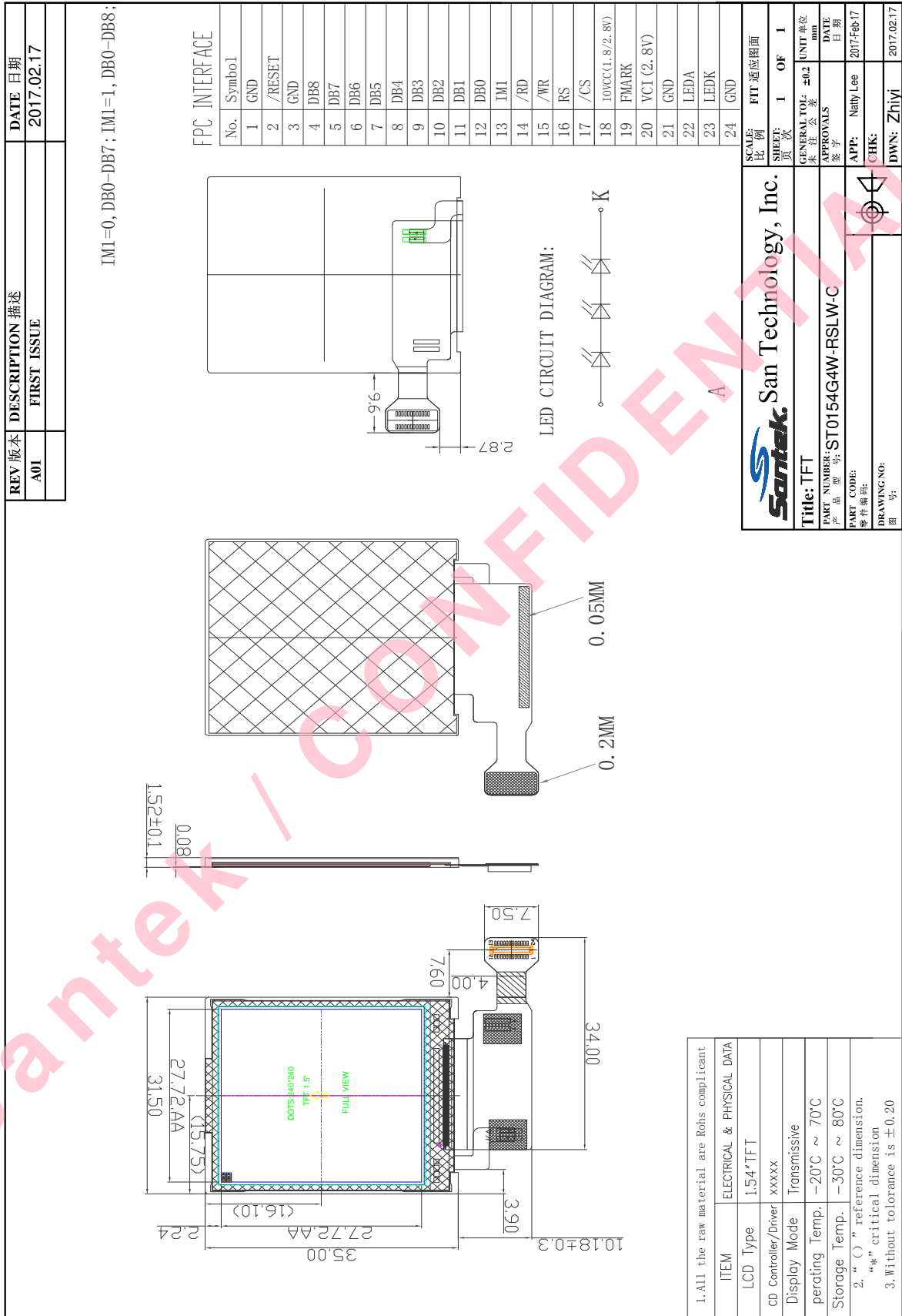

3. Interface Description

Table 2: Pin assignment

Pin No.	Symbol	I/O	Description	When not in use
1	GND	P	System Ground	
2	RESET	P	Reset Signal pin (“Low” is enable)	
3	GND	I/O	System Ground	
4-12	D8-D0	I	Data bus DB8~DB0	
13	IM1	I	The MCU interface mode select.:IM1=0,DB0-DB7;IM1=1,DB0-DB8	
14	/RD	I	Read enable in 8080 MCU parallel interface.	
15	/WR	I	Write enable in MCU parallel interface.	
16	RS	I	Display data/command selection pin in parallel interface.	
17	/CS	P	Chip selection pin	
18	IOVCC	I/O	Power supply Voltage for I/O	
19	FMARK	I	Tearing effect signal is used to synchronize MCU to frame memory.	
20	VCI	P	Digital Power Supply Voltage	
21	GND	I/O	System Ground	
22	LEDA	P	Backlight LED Anode.	
23	LEDK	P	Backlight LED Cathode	
24	GND	I/O	System Ground	

Note: The voltage power of the interface logic pin depend on “VCC” and “GND”, Such as DBn, R0~R7, G0~G7, B0~B7,IMn and function pins
I: input, O: output, P: Power

4. Absolute Maximum Ratings

Electrical Maximum Ratings (VSS=0V)

Table 3: Electrical Maximum Ratings – for IC

Parameter	Symbol	Min.	Max.	Unit	Note
Power supply voltage	VCI	-0.3	+3.6	V	GND=0
	IOVCC	-0.3	+3.6	V	GND=0

Note:

1. VCI, GND must be maintained.
2. The modules may be destroyed if they are used beyond the absolute maximum ratings.
3. Ta=25+/-2°C

5. Electrical Specifications

5.1 Typical Operation Conditions

(At Ta = 25 °C,)

Table 4

ITEM	SYMBOL	MIN	TYP	MAX	UNIT	NOTE
Digital Power Supply Voltage	VCI	3	2.8	3.3	V	-
Power Supply Voltage For I/O	IOVCC	1.64	1.8	3.3	V	-

5.2 Backlight Driving Conditions

Table 5

Parameter	Symbol	Condition	Min.	Typ.	Max.	Unit	Note
Forward Current	IF	-	18	20	30	mA	
Forward voltage	VF	IF=20mA	8.4	9.6	10.2	V	Note 1
Uniformity	△	IF=20mA	75	80	-	%	
Luminance (on the module surface, BM-7)	LV	IF=20mA	400	450	-	cd/m ²	
LED life time	-	IF=20mA	20,000	-	-	Hr	Note 2

Note 1: Constant current driving method.

The LED Supply Voltage is defined by the number of LED at Ta=25°C and IF =20mA.

Note 2: The “LED life time” is defined as the module brightness decrease to 50% original brightness at Ta=25°C and IF =20mA. The LED lifetime could be decreased if operating IF is larger than 20mA.

6. Optical Characteristics

Table 6: Optical specifications

Items	Symbol	Condition	Specifications			Unit
			Min.	Typ.	Max.	
Contrast Ratio	CR			900		-
Response Time	T_R+T_F			35	50	ms
Chromaticity	Red	X_R		TBD		-
		Y_R		TBD		-
	Green	X_G		TBD		-
		Y_G		TBD		-
	Blue	X_B		TBD		-
		Y_B		TBD		-
	White	X_W		TBD		-
		Y_W		TBD		-
Viewing angle	Hor.	$\Phi 1(3 \text{ o'clock})$	Center $CR \geq 10$		80	deg.
		$\Phi 2(9 \text{ o'clock})$			80	
	Ver.	$\theta 2(12 \text{ o'clock})$			80	
		$\theta 1(6 \text{ o'clock})$			80	
NTSC ratio				50		%

Note 1: Definition of Contrast Ratio (CR):

The contrast ratio can be calculated by the following expression.

$$\text{Contrast Ratio (CR)} = L_{63} / L_0$$

L63: Luminance of gray level 63

L0: Luminance of gray level 0

$$CR = CR(10)$$

CR (X) is corresponding to the Contrast Ratio of the point X at Figure in Note 5.

Note 2: Definition of Response Time (T_R , T_F):

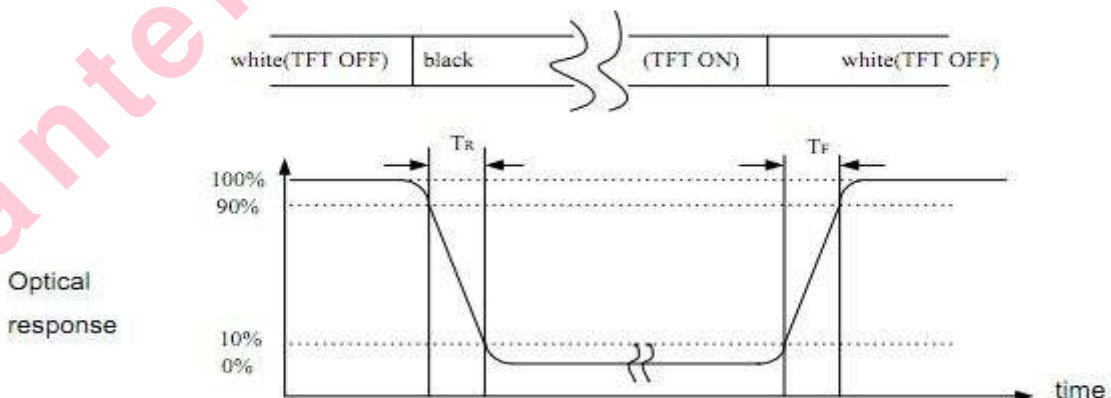

Figure 2

Note 3: Viewing Angle

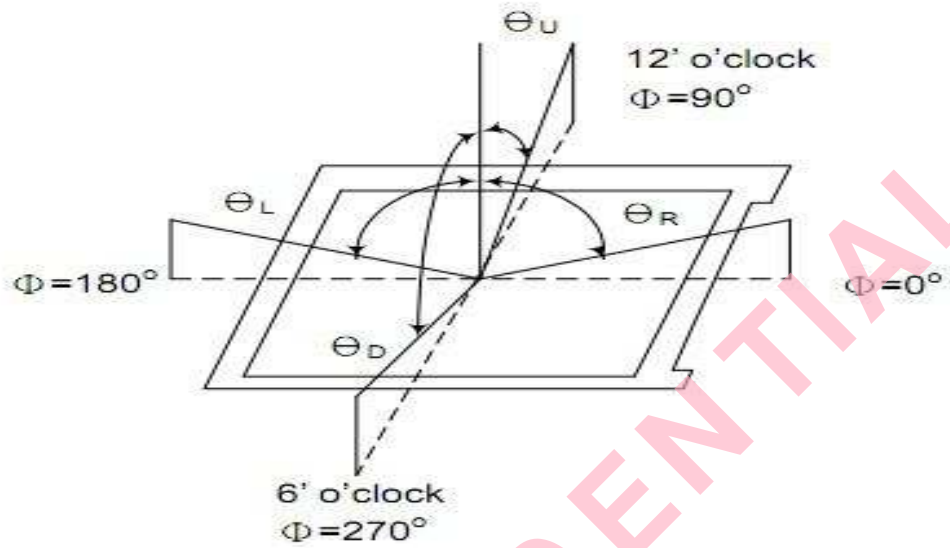

Figure 3

The above “Viewing Angle” is the measuring position with Largest Contrast Ratio; not for good image quality. View Direction for good image quality is ALL Viewing. Module maker can increase the “Viewing Angle” by applying Wide View Film.

Note 4: Measurement Set-Up:

The LCD module should be stabilized at a given temperature for 20 minutes to avoid abrupt temperature change during measuring. In order to stabilize the luminance, the measurement should be executed after lighting Backlight for 20 minutes in a windless room.

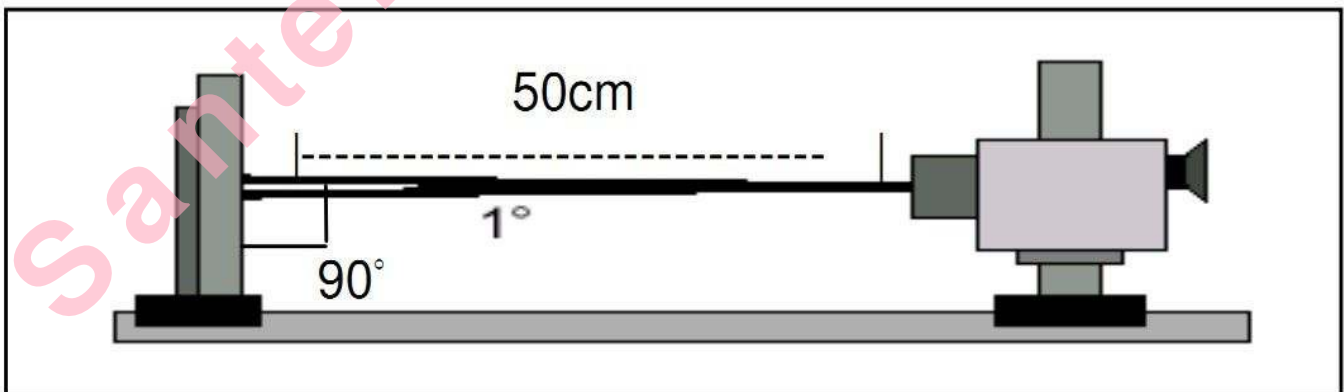

Figure 4

7. Data input Characteristics

7.1 The MPU Interface Mode Select

IM1	MPU Interface Mode	Data pin
0	80-8bit parallel I/F	DB[7:0]
1	80-9bit parallel I/F	DB[8:0]

7.2 8080 Series MCU Parallel interface Characteristics:18/16/9/8 Bus

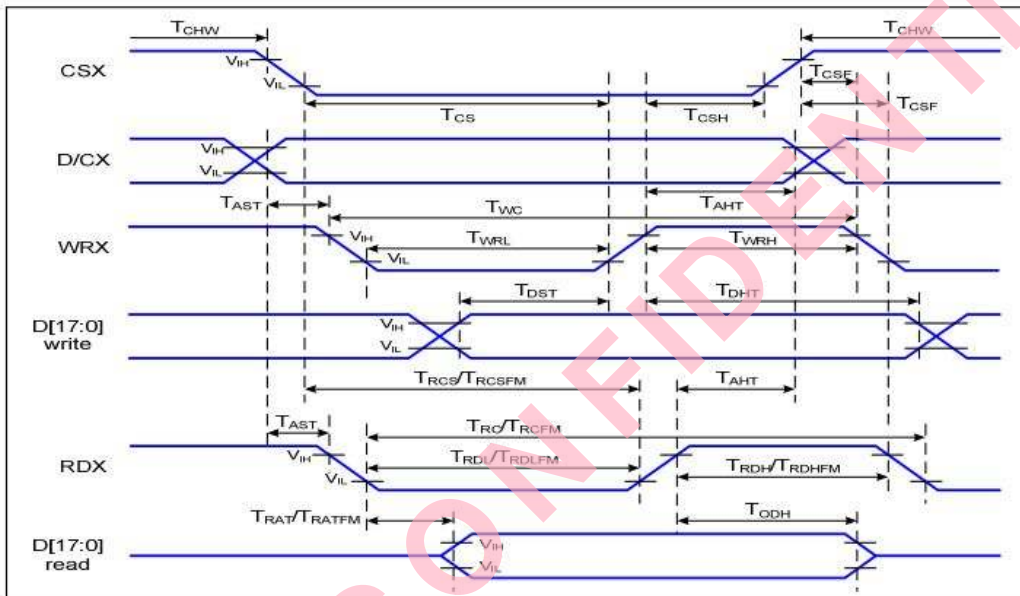

Figure 1 Parallel Interface Timing Characteristics (8080-Series MCU Interface)

VDDI=1.65 to 3.3V, VDD=2.4 to 3.3V, AGND=DGND=0V, Ta= -30 to 70 °C

Signal	Symbol	Parameter	Min	Max	Unit	Description
D/CX	T _{AST}	Address setup time	0		ns	-
	T _{AHT}	Address hold time (Write/Read)	10		ns	
CSX	T _{CHW}	Chip select "H" pulse width	0		ns	-
	T _{CS}	Chip select setup time (Write)	15		ns	
	T _{RCS}	Chip select setup time (Read ID)	45		ns	
	T _{RCSFM}	Chip select setup time (Read FM)	355		ns	
	T _{CSF}	Chip select wait time (Write/Read)	10		ns	
	T _{CSH}	Chip select hold time	10		ns	
WRX	T _{WC}	Write cycle	66		ns	-
	T _{WRH}	Control pulse "H" duration	15		ns	
	T _{WRL}	Control pulse "L" duration	15		ns	
RDX (ID)	T _{RC}	Read cycle (ID)	160		ns	When read ID data
	T _{RDH}	Control pulse "H" duration (ID)	90		ns	
	T _{RDL}	Control pulse "L" duration (ID)	45		ns	
RDX (FM)	T _{RCFM}	Read cycle (FM)	450		ns	When read from frame memory
	T _{RDHFM}	Control pulse "H" duration (FM)	90		ns	
	T _{RDLFM}	Control pulse "L" duration (FM)	355		ns	
D[17:0]	T _{DST}	Data setup time	10		ns	For CL=30pF

T _{DHT}	Data hold time	10		ns
T _{RAT}	Read access time (ID)		40	ns
T _{RATFM}	Read access time (FM)		340	ns
T _{ODH}	Output disable time	20	80	ns

Table 4 8080 Parallel Interface Characteristics

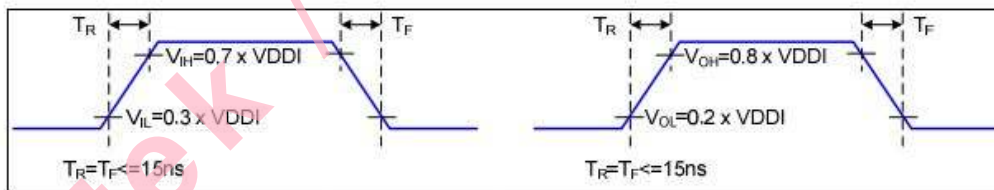

Figure 2 Rising and Falling Timing for I/O Signal

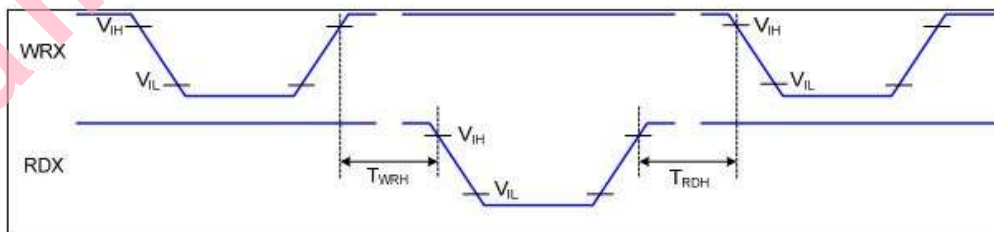

Figure 3 Write-to-Read and Read-to-Write Timing

Note: The rising time and falling time (T_r, T_f) of input signal and fall time are specified at 15 ns or less. Logic high and low levels are specified as 30% and 70% of VDDI for Input signals.

8. Environmental / Reliability Test

Table 8

Test Item	Test Condition	Test result determinant gist
High temperature storage	80±2°C;96H	the inspection of appearance and function character.
Low temperature storage	-30±2°C;96H	
High temperature/humidity storage	70°C±2°C,90%±3%RH;96H	
High temperature operation	70±2°C;96H	No objection of the function character; no fatal objection of the appearance.
Low temperature operation	-20±2°C;96H	
High temperature/humidity operation	60°C±3°C,90%±3%RH;96H	
Temperature Shock	-20±2°C,30min→60±2°C,30 min;10cycle	No objections of the appearance、 function & the whole structure

Remark:

- 1: Before cosmetic and function test, the product must have enough recovery time, at least 2~4 hours at room temperature.
2. The test samples should be applied to only one test item.
3. Sample size for each test item is 5~10pcs.
4. For Damp Proof Test, Pure water(Resistance>10MΩ) should be used.
5. In case of malfunction defect caused by ESD damage, if it would be recovered to normal state after resetting, it would be judged as a good part.
6. Failure Judgment Criterion: Basic Specification, Electrical Characteristic, Mechanical Characteristic, Optical Characteristic.

9. Inspection Criteria

9.1. Scope

The incoming inspection standards shall be applied to TFT –LCD Modules(hereinafter called "Modules") that supplied by Santek

9.2. Incoming Inspection

The customer shall inspect the modules within twenty calendar days of the delivery date (the "inspection period") at its own cost. The result of the inspection (acceptance or rejection) shall be recorded in writing, and a copy of this writing will be promptly sent to the seller. If the results of the inspecting from buyer does not send to the seller within twenty calendar days of the delivery date, the modules shall be regards as acceptance. Should the customer fail to notify the seller within the inspection period, the buyers right to reject the modules. Shall be lapsed and the modules shall be deemed to have been accepted by the buyer.

9.3 Inspection Sampling Method

10.3.1. Lot size: Quantity per shipment lot per model

10.3.2. Sampling type: Normal inspection, Single sampling

10.3.3. Inspection level: II

10.3.4. Sampling table: GB/T2828.1-2003

10.3.5. Acceptable quality level (AQL)

Major defect: AQL=0.65

Minor defect: AQL=1.00

9.4 Inspection Conditions:

10.4.1 Ambient conditions:

a. Temperature: Room temperature $25\pm 5^{\circ}\text{C}$

b. Humidity: $(60\pm 10)\% \text{RH}$

c. Illumination: Single fluorescent lamp non-directive (300 to 700 Lux)

10.4.2 Viewing distance

The distance between the LCD and the inspector's eyes shall be at least 35~40cm.

10.4.3 Viewing Angle

U/D: $45^{\circ}/45^{\circ}$, L/R: $45^{\circ}/45^{\circ}$

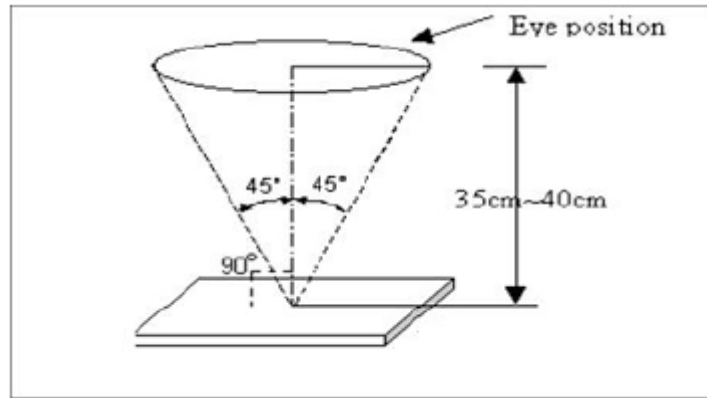

9.5 Defects are classified as major defects and minor defects according to the degree of defectiveness defined herein.

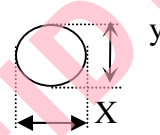
No	Item	Criterion for defects	Defect type																																														
1	Black/white spot defect (in displaying)	<p>black/white spot definition $\Phi = (x+y)/2$</p>  <p>1. black/white spot defect (≤ 4.0inch)</p> <table border="1"> <thead> <tr> <th rowspan="2">area size (mm)</th> <th colspan="3">Acceptable number</th> </tr> <tr> <th>A</th> <th>B</th> <th>C</th> </tr> </thead> <tbody> <tr> <td>$\Phi \leq 0.1$</td> <td colspan="3">ignore</td> </tr> <tr> <td>$0.1 < \Phi \leq 0.15$</td> <td colspan="3">3</td> </tr> <tr> <td>$0.15 < \Phi \leq 0.25$</td> <td colspan="3">2</td> </tr> <tr> <td>$\Phi > 0.25$</td> <td colspan="3">0</td> </tr> </tbody> </table> <p>2. black/white spot defect (> 4.0inch)</p> <table border="1"> <thead> <tr> <th rowspan="2">area size (mm)</th> <th colspan="3">Acceptable number</th> </tr> <tr> <th>A</th> <th>B</th> <th>C</th> </tr> </thead> <tbody> <tr> <td>$\Phi \leq 0.15$</td> <td colspan="3">ignore</td> </tr> <tr> <td>$0.15 < \Phi \leq 0.25$</td> <td colspan="3">2</td> </tr> <tr> <td>$0.25 < \Phi \leq 0.35$</td> <td colspan="3">1</td> </tr> <tr> <td>$\Phi > 0.35$</td> <td colspan="3">0</td> </tr> </tbody> </table>	area size (mm)	Acceptable number			A	B	C	$\Phi \leq 0.1$	ignore			$0.1 < \Phi \leq 0.15$	3			$0.15 < \Phi \leq 0.25$	2			$\Phi > 0.25$	0			area size (mm)	Acceptable number			A	B	C	$\Phi \leq 0.15$	ignore			$0.15 < \Phi \leq 0.25$	2			$0.25 < \Phi \leq 0.35$	1			$\Phi > 0.35$	0			Minor
area size (mm)	Acceptable number																																																
	A	B	C																																														
$\Phi \leq 0.1$	ignore																																																
$0.1 < \Phi \leq 0.15$	3																																																
$0.15 < \Phi \leq 0.25$	2																																																
$\Phi > 0.25$	0																																																
area size (mm)	Acceptable number																																																
	A	B	C																																														
$\Phi \leq 0.15$	ignore																																																
$0.15 < \Phi \leq 0.25$	2																																																
$0.25 < \Phi \leq 0.35$	1																																																
$\Phi > 0.35$	0																																																

2	Black/white line defect (in displaying)	1. black/white line defect (All inch)					Minor
		size (mm)		Acceptable number			
		L(length)	W(width)	area			
				A	B	C	
		10<L	0.03<W≤0.04	5			
		5.0<L≤10	0.04<W≤0.06	3			
1.0<L≤5.0	0.06<W≤0.07	2					
L≤1.0	0.07<W≤0.09	1			ignore		

Santek - CONFIDENTIAL

3	Blemish & foreign matters	<p>1. Dot (≤ 4.0inch LCD)</p> <table border="1"> <thead> <tr> <th rowspan="3">size(mm)</th> <th colspan="3">Acceptable number</th> </tr> <tr> <th colspan="3">area</th> </tr> <tr> <th>A</th> <th>B</th> <th>C</th> </tr> </thead> <tbody> <tr> <td>$\Phi \leq 0.1$</td> <td colspan="2">ignore</td> <td rowspan="4">ignore</td> </tr> <tr> <td>$0.10 < \Phi \leq 0.15$</td> <td colspan="2">2</td> </tr> <tr> <td>$0.15 < \Phi \leq 0.25$</td> <td colspan="2">1</td> </tr> <tr> <td>$0.25 < \Phi$</td> <td colspan="2">0</td> </tr> </tbody> </table>	size(mm)	Acceptable number			area			A	B	C	$\Phi \leq 0.1$	ignore		ignore	$0.10 < \Phi \leq 0.15$	2		$0.15 < \Phi \leq 0.25$	1		$0.25 < \Phi$	0		Minor
		size(mm)		Acceptable number																						
				area																						
A	B		C																							
$\Phi \leq 0.1$	ignore		ignore																							
$0.10 < \Phi \leq 0.15$	2																									
$0.15 < \Phi \leq 0.25$	1																									
$0.25 < \Phi$	0																									
<p>2. Dot (> 4.0inch LCD)</p> <table border="1"> <thead> <tr> <th rowspan="3">size(mm)</th> <th colspan="3">Acceptable number</th> </tr> <tr> <th colspan="3">area</th> </tr> <tr> <th>A</th> <th>B</th> <th>C</th> </tr> </thead> <tbody> <tr> <td>$\Phi \leq 0.15$</td> <td colspan="2">ignore</td> <td rowspan="4">ignore</td> </tr> <tr> <td>$0.15 < \Phi \leq 0.25$</td> <td colspan="2">2</td> </tr> <tr> <td>$0.25 < \Phi \leq 0.35$</td> <td colspan="2">1</td> </tr> <tr> <td>$\Phi > 0.35$</td> <td colspan="2">0</td> </tr> </tbody> </table>	size(mm)	Acceptable number			area			A	B	C	$\Phi \leq 0.15$	ignore		ignore	$0.15 < \Phi \leq 0.25$	2		$0.25 < \Phi \leq 0.35$	1		$\Phi > 0.35$	0				
size(mm)		Acceptable number																								
		area																								
	A	B	C																							
$\Phi \leq 0.15$	ignore		ignore																							
$0.15 < \Phi \leq 0.25$	2																									
$0.25 < \Phi \leq 0.35$	1																									
$\Phi > 0.35$	0																									
<p>3. Blemish (≤ 4.0inch on touch panle or between touch panel ane LCD)</p> <table border="1"> <thead> <tr> <th rowspan="3">size(mm)</th> <th colspan="3">Acceptable number</th> </tr> <tr> <th colspan="3">AREA</th> </tr> <tr> <th>A</th> <th>B</th> <th>C</th> </tr> </thead> <tbody> <tr> <td>$\Phi \leq 0.1$</td> <td colspan="2">ignore</td> <td rowspan="3">ignore</td> </tr> <tr> <td>$0.10 < \Phi \leq 0.15$</td> <td colspan="2">1</td> </tr> <tr> <td>$0.15 < \Phi$</td> <td colspan="2">0</td> </tr> </tbody> </table>	size(mm)	Acceptable number			AREA			A	B	C	$\Phi \leq 0.1$	ignore		ignore	$0.10 < \Phi \leq 0.15$	1		$0.15 < \Phi$	0							
size(mm)		Acceptable number																								
		AREA																								
	A	B	C																							
$\Phi \leq 0.1$	ignore		ignore																							
$0.10 < \Phi \leq 0.15$	1																									
$0.15 < \Phi$	0																									

		<p>4. Blemish(>4.0inch on touch panle or between touch panel ane LCD)</p> <table border="1"> <thead> <tr> <th rowspan="3">size(mm)</th> <th colspan="3">Acceptable number</th> </tr> <tr> <th colspan="3">AREA</th> </tr> <tr> <th>A</th> <th>B</th> <th>C</th> </tr> </thead> <tbody> <tr> <td>$\Phi \leq 0.15$</td> <td colspan="2">ignore</td> <td rowspan="4">ignore</td> </tr> <tr> <td>$0.15 < \Phi \leq 0.25$</td> <td colspan="2">2</td> </tr> <tr> <td>$0.25 < \Phi \leq 0.35$</td> <td colspan="2">1</td> </tr> <tr> <td>$\Phi > 0.35$</td> <td colspan="2">0</td> </tr> </tbody> </table> <p>5.line(All inch LCD/touch panle)</p> <table border="1"> <thead> <tr> <th colspan="2">size(mm)</th> <th colspan="3">Acceptable number</th> </tr> <tr> <th rowspan="2">L(length)</th> <th rowspan="2">W(width)</th> <th colspan="3">area</th> </tr> <tr> <th>A</th> <th>B</th> <th>C</th> </tr> </thead> <tbody> <tr> <td>Ignore</td> <td>$W \leq 0.02$</td> <td colspan="2">5</td> <td rowspan="4">ignore</td> </tr> <tr> <td>$L \leq 3.0$</td> <td>$0.02 < W \leq 0.03$</td> <td colspan="2">3</td> </tr> <tr> <td>$L \leq 2.0$</td> <td>$0.03 < W \leq 0.05$</td> <td colspan="2">2</td> </tr> <tr> <td>---</td> <td>$W > 0.05$</td> <td colspan="2">Treat with dot</td> </tr> </tbody> </table>	size(mm)	Acceptable number			AREA			A	B	C	$\Phi \leq 0.15$	ignore		ignore	$0.15 < \Phi \leq 0.25$	2		$0.25 < \Phi \leq 0.35$	1		$\Phi > 0.35$	0		size(mm)		Acceptable number			L(length)	W(width)	area			A	B	C	Ignore	$W \leq 0.02$	5		ignore	$L \leq 3.0$	$0.02 < W \leq 0.03$	3		$L \leq 2.0$	$0.03 < W \leq 0.05$	2		---	$W > 0.05$	Treat with dot		
size(mm)	Acceptable number																																																							
	AREA																																																							
	A	B	C																																																					
$\Phi \leq 0.15$	ignore		ignore																																																					
$0.15 < \Phi \leq 0.25$	2																																																							
$0.25 < \Phi \leq 0.35$	1																																																							
$\Phi > 0.35$	0																																																							
size(mm)		Acceptable number																																																						
L(length)	W(width)	area																																																						
		A	B	C																																																				
Ignore	$W \leq 0.02$	5		ignore																																																				
$L \leq 3.0$	$0.02 < W \leq 0.03$	3																																																						
$L \leq 2.0$	$0.03 < W \leq 0.05$	2																																																						
---	$W > 0.05$	Treat with dot																																																						
4	Stain on LCD panel surface	Stain which cannot be removed even when wiped lightly with a soft cloth or similar cleaning too are rejectable	Minor																																																					
5	Rust in bezel	Rust which is visible in the bezel is rejectable	Minor																																																					
6	Defect of land surface contact	Evident crevices which is visble are rejectable	Minor																																																					
7	Parts mounting	(1) failure to mount parts (2) parts not in the specification are mounted (3) polarith, for example,is reversed	Major Major Major																																																					
8	Parts alignment	(1) LSI,IC lead width is more than 50% beyond pad outline (2) Chip component is off center and more than 50% of the leads is off the pad outline	Minor Minor																																																					

9	Conductive foreign matter	(1) on open space(gnd,manual solder)solder ball is allowed up to Φ 0.1mm(1EA). (2) In case of shield space is allowed up to Φ 0.2mm(1EA)	Major
10	Faculty PWB correction	(1) due to PWB copper foil pattern burnout,the patter is connected,using a jumper wire for repair;2 or more places corrected per PWB (2) short circuited part is cut,and no resist coating has been performed.	Minor Minor

area definition

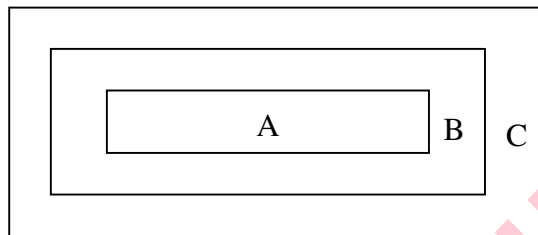

LCD inspection area

A: active area

B: visible area

C: outside of visible area (Invisible area after assembling)

Visible Defect in area c, but it cannot affect product's quality , it is allowed .

10 Suggestions for using LCD modules

10.1 Handling of LCM

10.1.1 The LCD screen is made of glass. Don't give excessive external shock, or drop from a high place.

10.1.2 If the LCD screen is damaged and the liquid crystal leaks out, do not lick and swallow. When the liquid is attach to your hand, skin, cloth etc, wash it off by using soap and water thoroughly and immediately.

10.1.3 Do not apply excessive force to the display surface or the adjoining areas since this may cause the color tone to vary. Do not touch the display with bare hands. This will stain the display area and degraded insulation between terminals (some cosmetics are determined to the polarizer).

10.1.4 The polarizer covering the display surface of the LCD module is soft and easily scratched. Handle this polarizer carefully. Do not touch, push or rub the exposed polarizers with anything harder than an HB pencil lead (glass, tweezers, etc.). Do not put or attach anything on the display area to avoid leaving marks on it. Condensation on the surface and contact with terminals due to cold will damage, stain or dirty the polarizer. After products are tested at low temperature they must be warmed up in a container before coming in to contact with room temperature air.

10.1.5 If the display surface becomes contaminated, breathe on the surface and gently wipe it with a soft dry cloth. If it is heavily contaminated, moisten cloth with one of the following solvents

-Isopropyl alcohol

- Ethyl alcohol

Do not scrub hard to avoid damaging the display surface.

10.1.6 Solvents other than those above-mentioned may damage the polarizer. Especially, do not use the following.

-Water

-Ketone

-Aromatic solvents

Wipe off saliva or water drops immediately, contact with water over a long period of time may cause deformation or color fading. Avoid contact with oil and fats.

10.1.7 Exercise care to minimize corrosion of the electrode. Corrosion of the electrodes is accelerated by water droplets, moisture condensation or a current flow in a high-humidity environment.

10.1.8 Install the LCD Module by using the mounting holes. When mounting the LCD module make sure it is free of twisting, warping and distortion. In particular, do not forcibly pull or bend the I/O cable or the backlight cable.

10.1.9 Do not attempt to disassemble or process the LCD module.

10.1.10 NC terminal should be open. Do not connect anything.

10.1.11 If the logic circuit power is off, do not apply the input signals.

10.1.12 Electro-Static Discharge Control, Since this module uses a CMOS LSI, the same careful attention should be paid to electrostatic discharge as for an ordinary CMOS IC. To prevent destruction of the elements by static electricity, be careful to maintain an optimum work environment.

-Before removing LCM from its packing case or incorporating it into a set, be sure the module and your body have the same electric potential. Be sure to ground the body when handling the LCD modules.

-Tools required for assembling, such as soldering irons, must be properly grounded. Make certain the AC power source for the soldering iron does not leak. When using an electric screwdriver to attach LCM, the screwdriver should be of ground potentiality to minimize as much as possible any transmission of electromagnetic waves produced sparks coming from the commutator of the motor.

-To reduce the amount of static electricity generated, do not conduct assembling and other work under dry conditions. To reduce the generation of static electricity be careful that the air in the work is not too dry. A relative humidity of 50%-60% is recommended. As far as possible make the electric potential of your work clothes and that of the work bench the ground potential.

- The LCD module is coated with a film to protect the display surface. Exercise care when peeling off this protective film since static electricity may be generated.

10.1.13 Since LCM has been assembled and adjusted with a high degree of precision, avoid applying excessive shocks to the module or making any alterations or modifications to it.

-Do not alter, modify or change the shape of the tab on the metal frame.

-Do not make extra holes on the printed circuit board, modify its shape or change the positions of components to be attached.

-Do not damage or modify the pattern writing on the printed circuit board.

-Absolutely do not modify the zebra rubber strip (conductive rubber) or heat seal connector.

-Except for soldering the interface, do not make any alterations or modifications with a soldering iron.

-Do not drop, bend or twist the LCM.

10.2. Handling Precautions for LCM

10.2.1 LCM is easy to be damaged. Please note below and be careful for handling

10.2.2 Correct handling;



As above picture, please handle with anti-static gloves around LCM edges.

10.2.3 Incorrect handling;

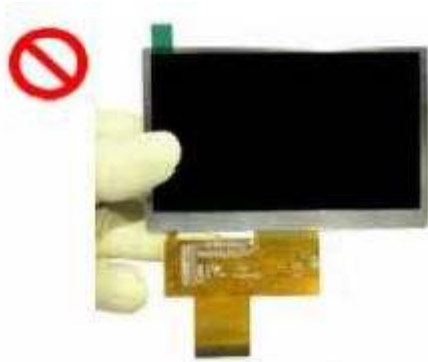

Please don't hold the surface of panel,



Please don't stretch the FPC

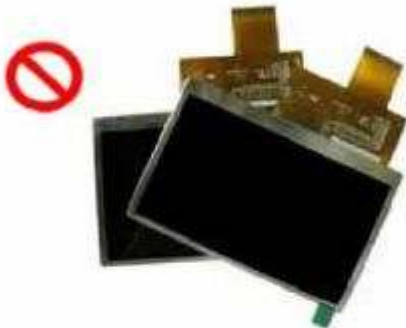

Please don't stack LCM.



Please don't hold the surface of IC.



Please don't press LCM



Please don't operation with sharp stick

10.3. Storage Precautions

10.3.1 When storing the LCD modules, the following precaution are necessary.

10.3.1.1 Store them in a sealed polyethylene bag. If properly sealed, there is no need for the desiccant.

10.3.1.2 Store them in a dark place. Do not expose to sunlight or fluorescent light, keep the temperature between 0°C and 35°C, and keep the relative humidity between 40%RH and 60%RH.

10.3.1.3 The polarizer surface should not come in contact with any other objects (We advise you to store them in the anti-static electricity container in which they were shipped).

10.3.2 Others

10.3.2.1 Liquid crystals solidify under low temperature (below the storage temperature range) leading to defective orientation or the generation of air bubbles (black or white). Air bubbles may also be generated if the module is subject to a low temperature.

10.3.2.2 If the LCD modules have been operating for a long time showing the same display patterns, the display patterns may remain on the screen as ghost images and a slight contrast irregularity may also appear. A normal operating status can be regained by suspending use for some time. It should be noted that this phenomenon does not adversely affect performance reliability.

10.3.2.3 To minimize the performance degradation of the LCD modules resulting from destruction caused by static electricity etc., exercise care to avoid holding the following sections when handling the modules.

- Exposed area of the printed circuit board.
- Terminal electrode sections.

10.4. Using LCD modules

10.4.1 Installing LCD Modules

The hole in the printed circuit board is used to fix LCM as shown in the picture below.

Attend to the following items when installing the LCM.

10.4.1.1 Cover the surface with a transparent protective plate to protect the polarizer and LC cell.

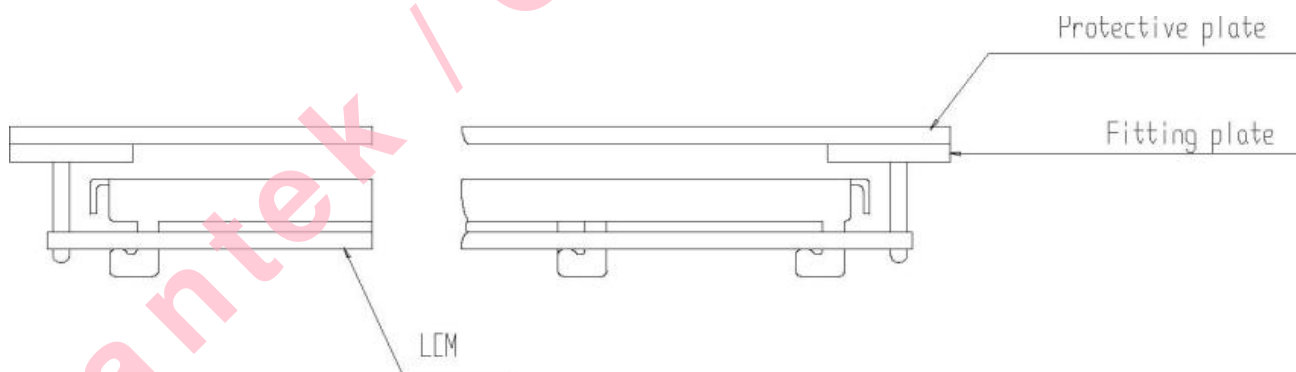

10.4.1.2 When assembling the LCM into other equipment, the spacer to the bit between the LCM and the fitting plate should have enough height to avoid causing stress to the module surface, refer to the individual specifications for measurements. The measurement tolerance should be ± 0.1 mm.

10.4.2 Precaution for assemble the module with BTB connector:

Please note the position of the male and female connector position, don't assemble or assemble like the method which the following picture shows

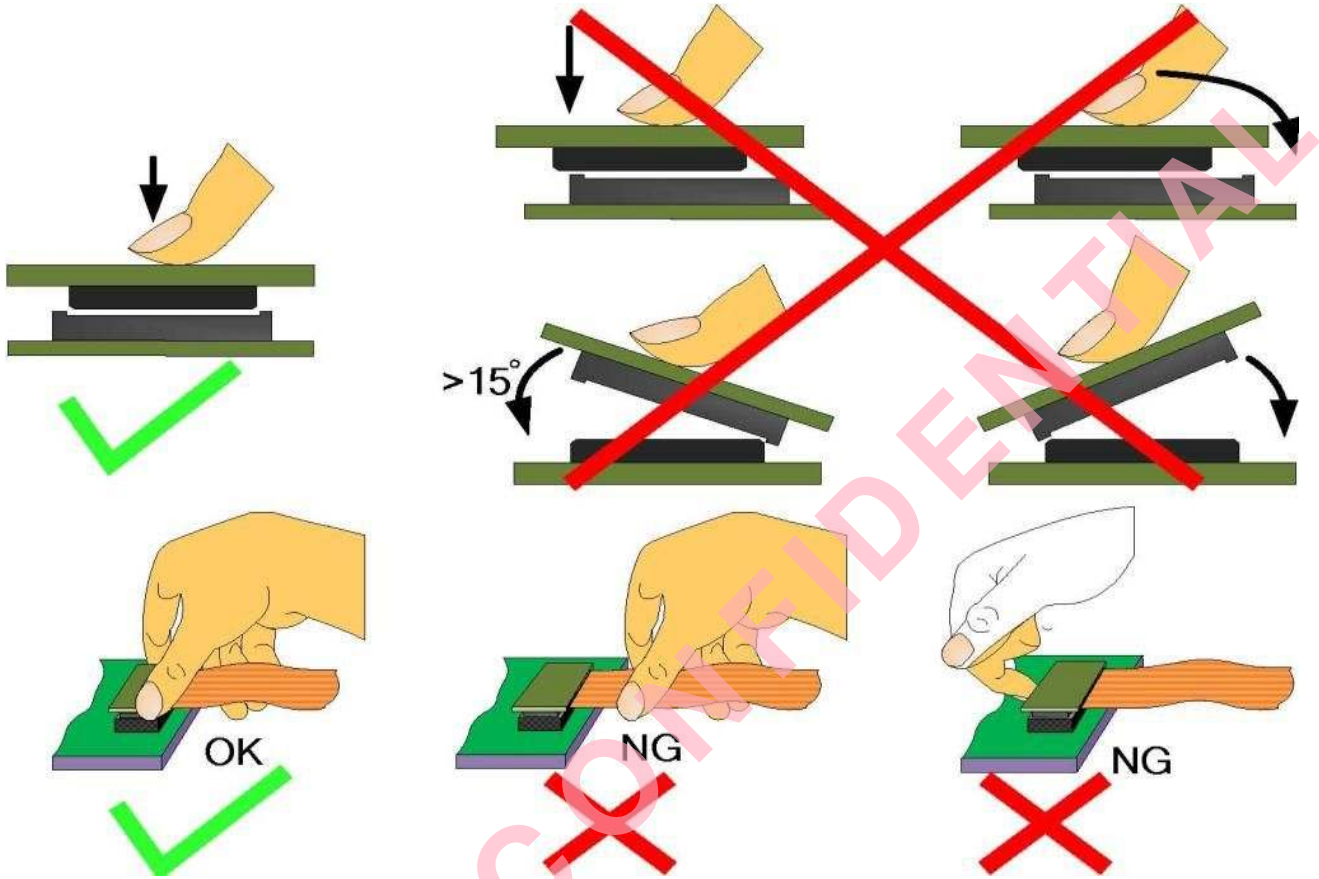

10.4.3 Precaution for soldering the LCM

	Manual soldering	Machine drag soldering	Machine press soldering
No RoHS Product	290°C ~350°C. Time : 3-5S.	330°C ~350°C. Speed : 4-8 mm/s.	300°C ~330°C. Time : 3-6S. Press: 0.8~1.2Mpa
RoHS Product	340°C ~370°C. Time : 3-5S.	350°C ~370°C. Time : 4-8 mm/s.	330°C ~360°C. Time : 3-6S. Press: 0.8~1.2Mpa

10.4.3.1 If soldering flux is used, be sure to remove any remaining flux after finishing to soldering operation (This does not apply in the of a non-halogen type of flux). It is recommended that you protect the LCD surfaccase e with a cover during soldering to prevent any damage due to flux spatters.

10.4.3.2 When soldering the electroluminescent panel and PC board, the panel and board should not be detached more than three times. This maximum number is determined by the temperature and time conditions mentioned above, though there may be some variance depending on the temperature of the soldering iron.

10.4.3.3 When remove the electroluminescent panel from the PC board, be sure the solder has completely melted, the soldered pad on the PC board could be damaged.

10.4.4 Precautions for Operation

10.4.4.1 Viewing angle varies with the change of liquid crystal driving voltage (VLCD). Adjust VLCD to show the best contrast.

10.4.4.2 It is an indispensable condition to drive LCD's within the specified voltage limit since the higher voltage then the limit cause the shorter LCD life. An electrochemical reaction due to direct current causes LCD's undesirable deterioration, so that the use of direct current drive should be avoided.

10.4.4.3 Response time will be extremely delayed at lower temperature than the operating temperature range and on the other hand at higher temperature LCD's show dark color in them. However those phenomena do not mean malfunction or out of order with LCD's, which will come back in the specified operating temperature.

10.4.4.4 If the display area is pushed hard during operation, the display will become abnormal. However, it will return to normal if it is turned off and then back on.

10.4.4.5 A slight dew depositing on terminals is a cause for electro-chemical reaction resulting in terminal open circuit. Usage under the maximum operating temperature, 50%RH or less is required.

10.4.4.6 Input logic voltage before apply analog high voltage such as LCD driving voltage when power on. Remove analog high voltage before logic voltage when power off the module. Input each signal after the positive/negative voltage becomes stable.

10.4.4.7 Please keep the temperature within the specified range for use and storage. Polarization degradation, bubble generation or polarizer peel-off may occur with high temperature and high humidity.

10.4.5 Safety

10.4.5.1 It is recommended to crush damaged or unnecessary LCDs into pieces and wash them off with solvents such as acetone and ethanol, which should later be burned.

10.4.5.2 If any liquid leaks out of a damaged glass cell and comes in contact with the hands, wash off thoroughly with soap and water.

11. Packing Specification (Reference only)

11.1 Packing Method

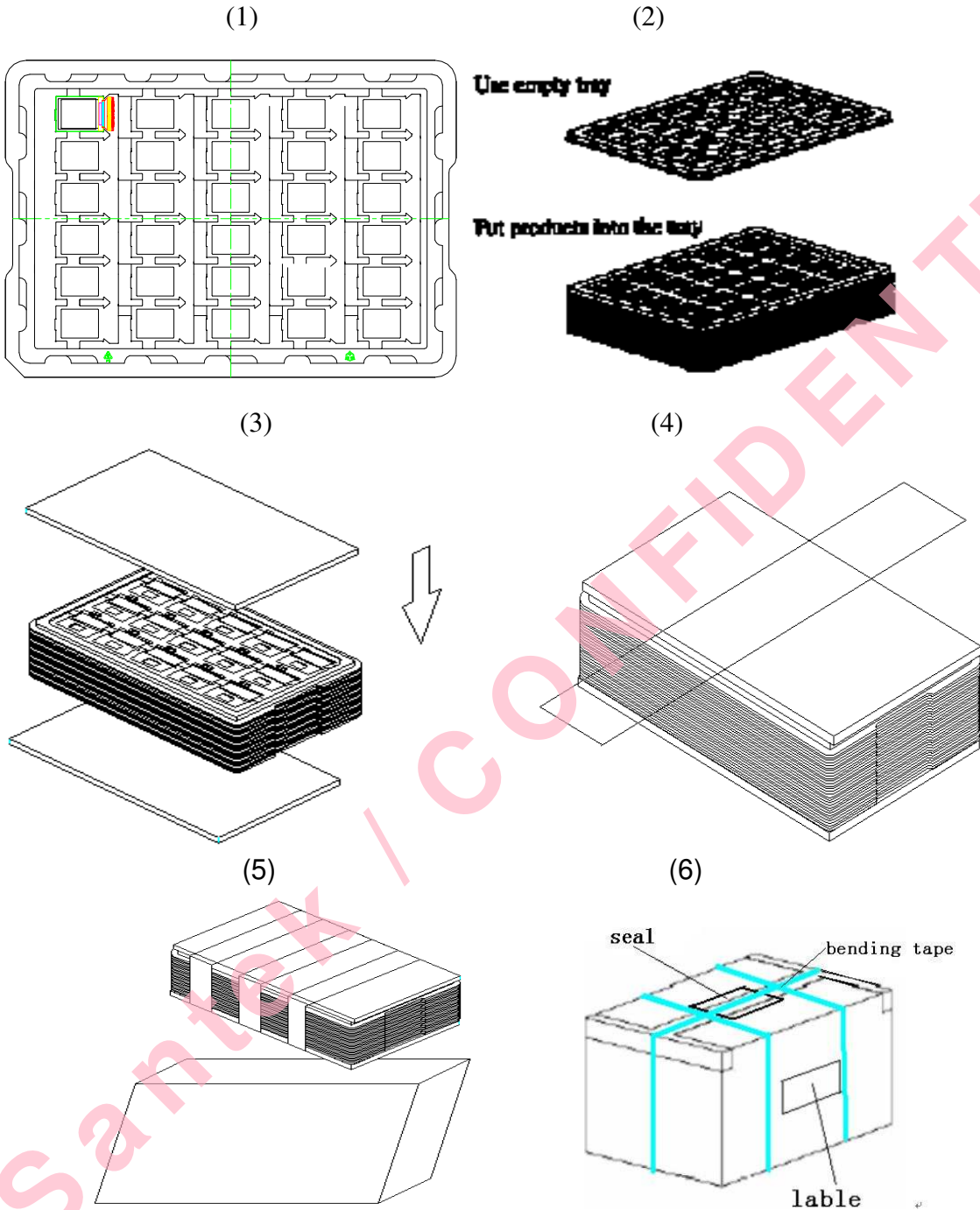

1. Put module into tray cavity:
2. Tray stacking
3. Put 1 cardboard under the tray stack and 1 cardboard above:
4. Fix the cardboard to the tray stack with adhesive tape:
5. Put the tray stack into carton.
6. Carton sealing with adhesive tape.