

THIS DRAWING IS UNPUBLISHED. RELEASED FOR PUBLICATION
 © COPYRIGHT - By - ALL RIGHTS RESERVED.

LOC		DIST		REVISIONS			
P	LTR	DESCRIPTION		DATE	DWN	APVD	
GP	00	AR4	REVISED PER ECO-11-004835	11MAR11	RK	HMR	

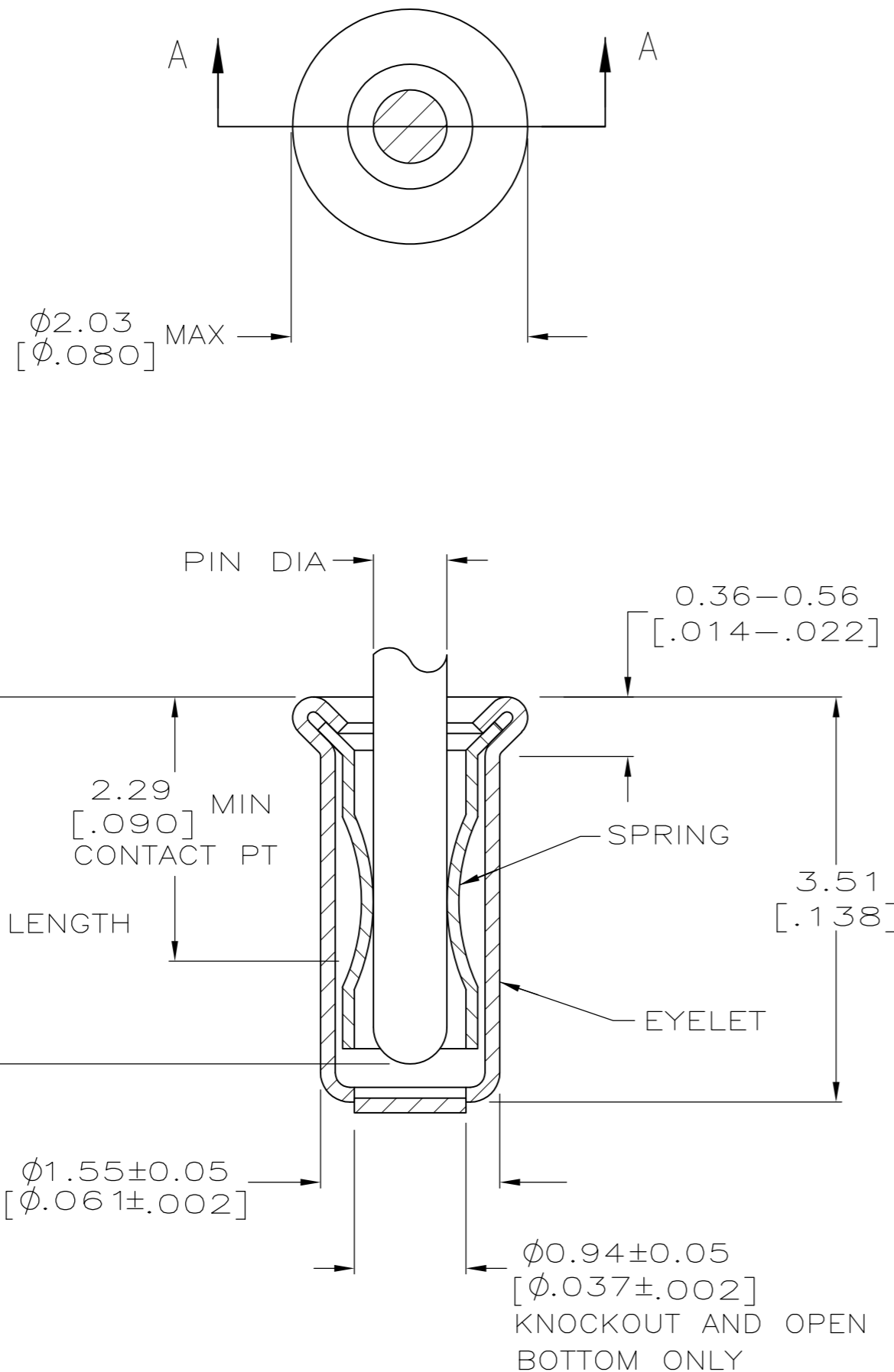

SECTION A-A

- 10 MATERIAL: SPRING COPPER QQ-C-533 EYELET: COPPER QQ-C-576
- 11 OBSOLETE PARTS: OBSOLETE CIS STREAMLINING PER D.RENAUD/D.SINISI

- 1 TIN PER MIL-T-10727 OR TIN LEAD 0.00254 [.000100] MIN THK.
- 2 GOLD PER MIL-G-45204, TYPE II, 0.00076 [.000030] MIN THK OVER NICKEL PER QQ-N-290 0.00028 [.000011] MIN THK ON CONTACT AREA.
- 3 GOLD FLASH PER MIL-G-45204, TYPE II, 0.13 μm [.000005] MIN THK. OVER NICKEL PLATE PER QQ-N-290 0.51 μm-1.52 μm [.000020-.000060] EXT THK.
- 4 TIN PER MIL-T-10727 OR TIN LEAD 0.00381 [.000150] MIN THK.
- 5. RECOMMENDED HOLE SIZE, PLATED OR UNPLATED:
 MACHINE INSERTION: 1.57 ^{+0.10}/_{-0.08} [.062 ^{+0.004}/_{-0.003}]
 HAND INSERTION: 1.60 ^{+0.10}/_{-0.00} [.063 ^{+0.004}/_{-0.000}]
- 6. APPLICATION TOOL PART NUMBER: MACHINE NO. 682127-4
 INSERTION HEAD NO. 682039-3
- 7 TO INSURE PROPER SPRING TENSION DO NOT EXCEED A 0.05 [.002] DIFFERENCE IN PIN DIA WHEN CHANGING TO A SMALLER PIN.
- 8. BOTTOM PLUG KNOCKOUT TOOL PART NUMBER 69729 WITH TIP PART NUMBER 69728-1.
- 9 TIN PER ASTM B 545, 0.00254 [.000100] MIN THK.

9	CLOSED	0.76-0.84 [.030-.033]	TIN 9	TIN 9	8-331677-3
	OPEN	0.76-0.84 [.030-.033]	TIN 4	GOLD 2	7-331677-4
OBSOLETE		0.76-0.84 [.030-.033]	TIN 1		7-331677-3
OBSOLETE					7-331677-1
OBSOLETE	CLOSED	0.66-0.74 [.026-.029]		GOLD 2	3-331677-8
OBSOLETE		0.56-0.64 [.022-.025]	TIN 1	TIN 1	3-331677-7
OBSOLETE	KNOCKOUT	0.76-0.84 [.030-.033]			3-331677-5
OBSOLETE		0.66-0.74 [.026-.029]			3-331677-4
OBSOLETE		0.76-0.84 [.030-.033]	GOLD 3	GOLD 2	3-331677-2
OBSOLETE		0.66-0.74 [.026-.029]			3-331677-0
11 OBSOLETE		0.76-0.84 [.030-.033]			2-331677-9
		0.66-0.74 [.026-.029]			2-331677-7
		0.76-0.84 [.030-.033]			2-331677-6
		0.66-0.74 [.026-.029]			2-331677-4
	OPEN				2-331677-3
		0.76-0.84 [.030-.033]	TIN 1	GOLD 2	2-331677-2
		0.56-0.64 [.022-.025]		TIN 1	2-331677-1
		0.76-0.84 [.030-.033]		GOLD 2	2-331677-0
		0.56-0.64 [.022-.025]		TIN 1	1-331677-9
		0.76-0.84 [.030-.033]		GOLD 2	1-331677-8
		0.56-0.64 [.022-.025]	GOLD 3	GOLD 2	1-331677-7
	CLOSED	0.76-0.84 [.030-.033]	TIN 1	TIN 1	1-331677-6
		0.56-0.64 [.022-.025]			1-331677-5
		0.76-0.84 [.030-.033]	GOLD 3	GOLD 2	1-331677-4
		0.56-0.64 [.022-.025]	TIN 1	TIN 1	1-331677-3
		0.66-0.74 [.026-.029]	GOLD 3	GOLD 2	1-331677-1
		0.66-0.74 [.026-.029]	TIN 1	TIN 1	1-331677-0
	BOTTOM TYPE	RECOMMENDED PIN DIA	EYELET	SPRING	PART NO

THIS DRAWING IS A CONTROLLED DOCUMENT. DWN R. TALLEY 4-5-91
 CHK -
 APVD -
 PRODUCT SPEC -
 APPLICATION SPEC -
 WEIGHT -

DIMENSIONS: mm [INCHES]
 TOLERANCES UNLESS OTHERWISE SPECIFIED:
 0 PLC ± -
 1 PLC ± -
 2 PLC ± -
 3 PLC ± 0.20 [.008]
 4 PLC ± -
 ANGLES ± -
 FINISH -

MATERIAL 10

TE Connectivity
 MINIATURE SPRING SOCKRT ASSEMBLY

SIZE A2 CAGE CODE 00779 DRAWING NO C=331677 RESTRICTED TO -
 SCALE 1:1 SHEET 1 OF 1 REV AR4