

MATERIAL NUMBER	ENGINEERING NUMBER	TAPE MATERIAL NUMBER	TAPE ENGINEERING NUMBER	STUD SIZE	S ±.005/0.13
190420004	B-148-06	190420005	B-148-06T	06	.146/3.71
190420006	B-148-08	190420007	B-148-08T	08	.173/4.39
190420008	B-148-10	190420009	B-148-10T	10	.198/5.03

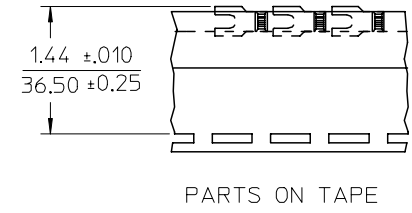
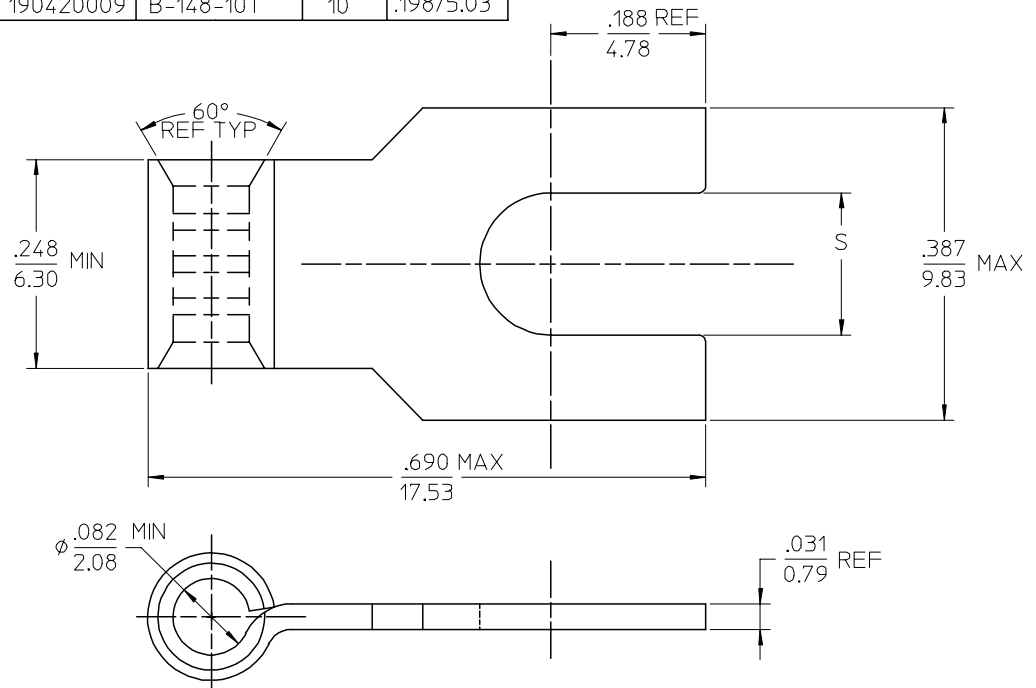

PARTS ON TAPE

SALES DRAWING

- NOTES:
- MATERIAL: COPPER
PLATING ELECTRO TIN.

NEW RELEASE EC NO: ETC2005-0122 DRW: BENDERLE 2005/02/15 CHKDR: DEROSS 2005/02/15 APPR: RDEROSS 2005/02/15	DESCRIPTION REV: A	QUALITY SYMBOLS ▽=0 ▽=0	GENERAL TOLERANCES (UNLESS SPECIFIED)		DIMENSION STYLE IN/MM	SCALE 4:1	DESIGN UNITS INCH	THIRD ANGLE PROJECTION		
		4 PLACES ± --- ± --- 3 PLACES ± --- ± --- 2 PLACES ± --- ± --- 1 PLACE ± --- ± ---	mm INCH	DRAWN BY BENDERLE	DATE 2005/02/01	TITLE FLAG SPADE TONGUE TERMINAL KRIMPTITE 16-14 AWG				
		ANGULAR ± --- °	DRAFT WHERE APPLICABLE MUST REMAIN WITHIN DIMENSIONS	CHECKED BY RDEROSS	DATE 2005/02/01	APPROVED BY RDEROSS				
		MATERIAL NO. SEE CHART	DOCUMENT NO. SD-19042-001	MOLEX INCORPORATED			SHEET NO. 1 OF 1			