

USB 2.0 High-Speed and Audio Switches with Negative Signal Capability

Features

- Single +2.7V to +4.4V Supply Voltage
- Low 50µA Supply Current
- -3dB Bandwidth: 1500MHz (typ)
- Low 2.5Ω(typ) On-Resistance
- THD+N: 0.02%
- Shorting D+/R and D-/L to Vbus will not cause leakage when $V_{DD} = 0$
- Internal Shunt Resistors for Click-and-Pop Reduction
- VBUS Detection for Automatic Switch Path Selection
- Totally Lead-Free & Fully RoHS Compliant (Notes 1 & 2)
- Halogen and Antimony Free. “Green” Device (Note 3)
- Packaging (Pb-free & Green available):
 - 10-pin contact UQFN, 1.4 x 1.8, (ZM10)

Description

The PI3USB223 combines AC coupled audio signals and USB2.0 HS (480Mbps) on the same pins. This enables users to use a single connector to drive either a USB end point or an audio end point.

PI3USB223 incorporates gate pump technology required to maintain low Ron for ideal audio THD while reducing the capacitance affect of high speed USB signals. The device also incorporates a substrate pump technology which allows -2V signals to pass through the switch without causing any leakage.

The PI3USB223 features protection on D+/R and D-/L to ensure no damage will happen to the IC if these pins are shorted accidentally to Vbus as well as ensuring there is no leakage when V_{DD} is on or off. Also, it includes VBUS detection (VB) to automatically switch to the USB signal path upon detection of a valid VBUS signal. It also features internal shunt resistors on the audio path to reduce clicks and pops heard during output. The device is available in a space-saving 10-pin, 1.4mm x 1.8mm UQFN package, and operate over the -40°C to +85°C temperature range.

Block Diagram

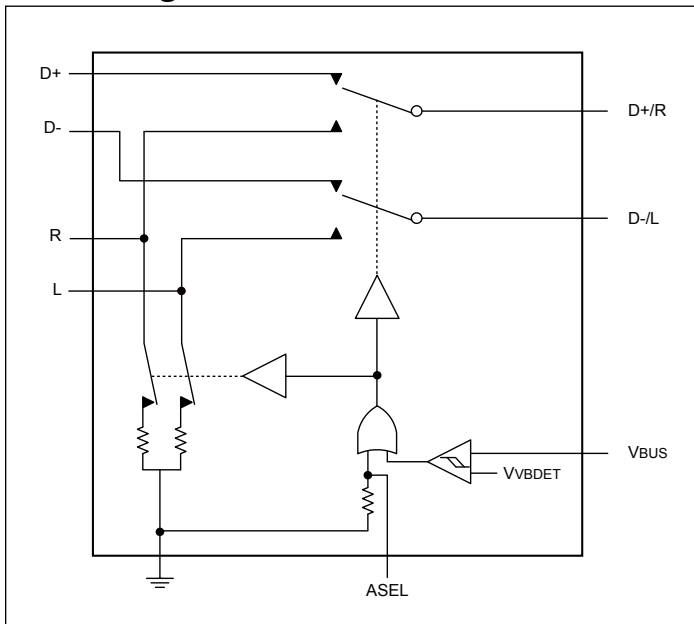

Truth Table

ASEL	V _{DD}	VBUS	L/R	D+/D-	L/R Shunt
X	L	L	OFF	OFF	OFF
X	H	L	OFF	OFF	ON
X	L	H	OFF	OFF	OFF
L	H	H	OFF	ON	ON
H	H	H	ON	OFF	OFF

Notes:

1. No purposely added lead. Fully EU Directive 2002/95/EC (RoHS), 2011/65/EU (RoHS 2) & 2015/863/EU (RoHS 3) compliant.
2. See <https://www.diodes.com/quality/lead-free/> for more information about Diodes Incorporated’s definitions of Halogen- and Antimony-free, “Green” and Lead-free.
3. Halogen- and Antimony-free “Green” products are defined as those which contain <900ppm bromine, <900ppm chlorine (<1500ppm total Br + Cl) and <1000ppm antimony compounds.

Pin Configuration

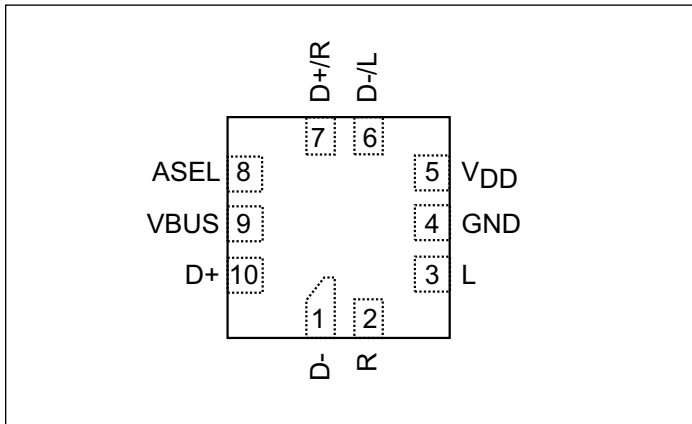

Pin Description

Pin#	Name	Description
1	D-	USB D- from system side
2	R	Audio Input (Right)
3	L	Audio Input (Left)
4	GND	Ground
5	V _{DD}	Positive Supply Voltage Input. Bypass V _{DD} to GND with a 0.1μF capacitor as close to the device as possible.
6	D-/L	Common Terminal for D- or Left Audio
7	D+/R	Common Terminal for D+ or Right Audio
8	ASEL	Switch SEL to override VBUS detection when VBUS and V _{DD} are both high. If ASEL is HIGH, then audio path will be on If ASEL is LOW then USB path will be on ASEL has an internal 3M-ohm pull-down
9	VBUS	If ASEL is tied LOW, then VBUS detection can be used for auto switching. If ASEL is LOW VBUS = HIGH means USB path is active
10	D+	USB D+ from system side

Maximum Ratings

(Above which useful life may be impaired. For user guidelines, not tested.)

(Voltages referenced to GND.)	
V _{DD} , ASEL	-0.3V to +5.0V
V _{BUS}	-0.3V to +5.5V
V _(R/D+) and V _(L/D-) ⁽¹⁾	-2.0V to +5.0V
V _(R/D+) and V _(L/D-) ⁽²⁾	-0.3V to +5.0V
V _R and V _L	-2.0V to (V _{DD} + 0.3V)
V _{D+} and V _{D-}	-0.3V to (V _{DD} + 0.3V)
Continuous Current into Any Terminal	±100mA
Continuous Power Dissipation (T _A = +70°C) 10-Pin UQFN (derate 6.9mW/°C above +70°C)	559mW
Junction-to-Case Thermal Resistance (θ _{JC}) ⁽²⁾	
10-Pin UQFN	20.1°C/W
Junction-to-Ambient Thermal Resistance (θ _{JA}) ⁽²⁾	
10-Pin UQFN	143.1°C/W
Operating Temperature Range	-40°C to +85°C
Junction Temperature Range	-40°C to +150°C
Storage Temperature Range	-65°C to +150°C
Lead Temperature (soldering, 10s)	+300°C

Notes:

1. If Audio path is enabled
2. If USB path is enabled

Stresses greater than those listed under MAXIMUM RATINGS may cause permanent damage to the device. This is a stress rating only and functional operation of the device at these or any other conditions above those indicated in the operational sections of this specification is not implied. Exposure to absolute maximum rating conditions for extended periods may affect reliability.

DC Electrical Characteristics

(V_{DD} = 2.7V to 4.4V, T_A = -40°C to +85°C, unless otherwise noted. Typical values are at V_{DD} = 3.0V to 3.6V, T_A = 25°C)

Parameter	Symbol	Test Conditions	Min.	Typ.	Max.	Units
Operating Power-supply range	V _{DD}		2.7	-	4.4	V
Supply Current	I _{CC}	V _{DD} = 3.3V ASEL = V _{BUS} = 0V	-	-	50	μA
Power-supply Rejection Ratio	PSRR	f = 10kHz, V _{DD} = 3.0 ± 0.3V, R _{D+/R-} = 50Ω	-	60	-	dB
Analog Signal Range	V _{D+/-}		0		V _{DD}	V
	V _{R/L}		-2		V _{DD}	
R/L On-Resistance	R _{ON(R/L)}	V _{DD} = 3.0V, V _{R/L} = -1.5V, +1.5V, I _{D+/R-} and D-/L = 10mA		2	5	Ω
D+/D- On-Resistance	R _{ON(D+/-)}	V _{DD} = 3.0V, V _{D+/-} = -0.4V to 0.6V, I _{D+/R-} and D-/L = 10mA		3.5	6	
		V _{DD} = 3.0V, V _{D+/R-} and D-/L = 0V to 3.0V, I _{D+/R-} and D-/L = 10mA			12	
R/L On-Resistance Match between Channels	ΔR _{ON(R/L)}	V _{DD} = 3.0V, V _{R/L} = 0V, I _{D+/R-} and D-/L = 10mA			0.2	
D+/- On-Resistance Match between Channels	ΔR _{ON(D+/-)}	V _{DD} = 3.0V, V _{D+/-} = 0V, I _{D+/R-} and D-/L = 10mA			0.2	
R/L On-Resistance Flatness	R _{FLAT(R/L)}	V _{DD} = 3.0V, I _{D+/R-} and D-/L = 10mA, V _{R/L} = -1.5V to +1.5V		0.3	0.5	

DC Electrical Characteristics Cont.

Parameter	Symbol	Test Conditions	Min.	Typ.	Max.	Units
D+/D- On-Resistance Flatness	$R_{FLAT(D+/-)}$	$V_{DD} = 3.0V, I_{D+/R}$ and $D-/L = 10mA, V_{D+/-} = -0.4V$ to $0.6V$		0.25	0.5	Ω
Shunt Switch Resistance	R_{SH}	Voltage on R or L = V_{DD}		25		$k\Omega$
D+/- Off-Leakage Current	$I_{D+/-}(OFF)$	$V_{DD} = 3.0V, V_{D+/-} = 5V, V_{D+/R}$ and $D-/L = -1.5V, +2.5V$	-1		1	μA
R/L Off-Leakage Current	$I_{R/L}(OFF)$	$V_{DD} = 3.0V, V_{R/L} = 0V, V_{D+/R}$ and $D-/L = 0V, +2.5V$	-1		1	μA
D+/R and D-/L Off-Leakage Current	$I_{D+/R}$ and $D-/L(OFF)$	$V_{DD} = 3.0V, V_{D+/R}$ and $D-/L = 3.6V, V_{D+/-} = V_{R/L} = 0V$			5	μA
		$V_{DD} = 3.3V, V_{D+/R}$ and $D-/L = 0V, V_{D+/-} = V_{R/L} = 0V$			5	μA
		$V_{DD} = 0V, V_{D+/R}$ or $D-/L = 5.0V, V_{D+/-} = V_{R/L} = 0V$			5	μA
System Bus Input Voltage	V_{BUS}		0		5.5	V
D+/R and D-/L On-Leakage Current	$I_{D+/R}$ and $D-/L(ON)$	USB Mode $V_{DD} = 3.0V, V_{R/L} = 0V, 2.5V$, unconnected, $V_{D+/R}$ and $D-/L = 0V, 2.5V$	-200		200	nA
		Audio Mode $V_{DD} = 3.0V, V_{D+/-} = 0V, 2.5V$, unconnected, $V_{D+/R}$ and $D-/L = -1.5V, +2.5V$	-200		200	nA
Turn-On Time	t_{ON}	R/L to D-/L or D+/R, $V_{DD} = 3.0V$, Fig. 2 $V_{R/L} = 1.5V, Z_L = 50\text{-ohm}/35pF, ASEL = V_{DD}, V_{BUS} = 5.0V$ to $0V$		12	60	μs
		D+/- to D-/L or D+/R, $V_{DD} = 3.0V$, Fig. 2 $V_{R/L} = 1.5V, Z_L = 50\text{-ohm}/35pF, V_{VBUS} = 5.0V, ASEL = 0V$ to V_{DD}		12	60	μs
Turn-Off Time	t_{OFF}	R/L to D-/L or D+/R, $V_{DD} = 3.0V$, Fig. 2 $V_{R/L} = 1.5V, Z_L = 50\text{-ohm}/35pF, ASEL = V_{DD}, V_{BUS} = 5.0V$ to $0V$		1.4	5	μs
		D+/- to D-/L or D+/R, $V_{DD} = 3.0V$, Fig. 2 $V_{R/L} = 1.5V, Z_L = 50\text{-ohm}/35pF, V_{VBUS} = 5.0V, ASEL = 0V$ to V_{DD}		0.7	5	μs
Break-Before-Make Time Delay	t_D	$Z_L = 50\Omega // 35pF$		13.5		μs

DC Electrical Characteristics Cont.

Parameter	Symbol	Test Conditions	Min.	Typ.	Max.	Units
Output Skew Same Switch	$t_{SK(P)}$	Figure 3		10		ps
Output Skew Between Switches	$t_{SK(O)}$	Figure 3		10		
R/L Off-Capacitance	$C_{R/L(OFF)}$	$V_{D+/R}$ and $D-/L = 0.5V_{PP}$, DC Bias = 0V, $f = 1MHz$,		3		pF
D+/- Off-Capacitance	$C_{D+/(OFF)}$	$V_{D+/R}$ and $D-/L = 1.5V_{PP}$, DC Bias = 0V, $f = 240MHz$,		2.5		
On-Capacitance	$C_{D+/R}$ and $D-/L(ON)$	USB Path, $F = 240MHz$, DC bias = 0V		9		
		Audio path, $f = 100kHz$, DC bias = 0V		8		
AC PERFORMANCE						
R/L -3dB Bandwidth	$BW_{R/L}$	$R_S = R_L = 50\Omega$, $V_{R/L} = 0dBm$, Figure 4		1100		MHz
D+/- -3dB Bandwidth	$BW_{D+/-}$	$R_S = R_L = 50\Omega$, $V_{D+/-} = 0dBm$, Figure 4		1500		
Insertion Loss	$I_{N(USB Path)}$	Frequency = 240MHz		-0.5		dB
Off Isolation	I_{SO}	Figure 4, $f = 240MHz$		-35		
Crosstalk	X_{TALK}	$f = 100kHz$, $V_{COM} = 1V_{RMS}$, $R_S = R_L = 50\Omega$, Figure 4		-80		
Total Harmonic Distortion + Noise	THD + N (for audio path)	R/L to D+/R and D-/L, $f = 20Hz$ to 20kHz, $V_{D+/R}$ and $D-/L = 0.5V_{PP}$, DC Bias = 0V, $R_L = 600\Omega$		0.02		%
LOGIC INPUT						
Input Logic High	V_{IH} for ASEL		1.6			V
Input Logic Low	V_{IL} for ASEL				0.4	
	V_{IH} for Vbus		3.5		5.5	
	V_{IL} for Vbus		0		0.6	
Input Leakage Current	I_{IN}	VASEL and VVbus = 0V or V_{DD}	-10		10	μA
ESD PROTECTION						
All Pins		Human Body Model		± 2		kV
D+/R, D-/L, and VBUS		Human Body Model		± 12		
D+/R, D-/L, and VBUS		Contact, IEC61000-4-2		± 8		

PI3USB223

Switching Waveforms

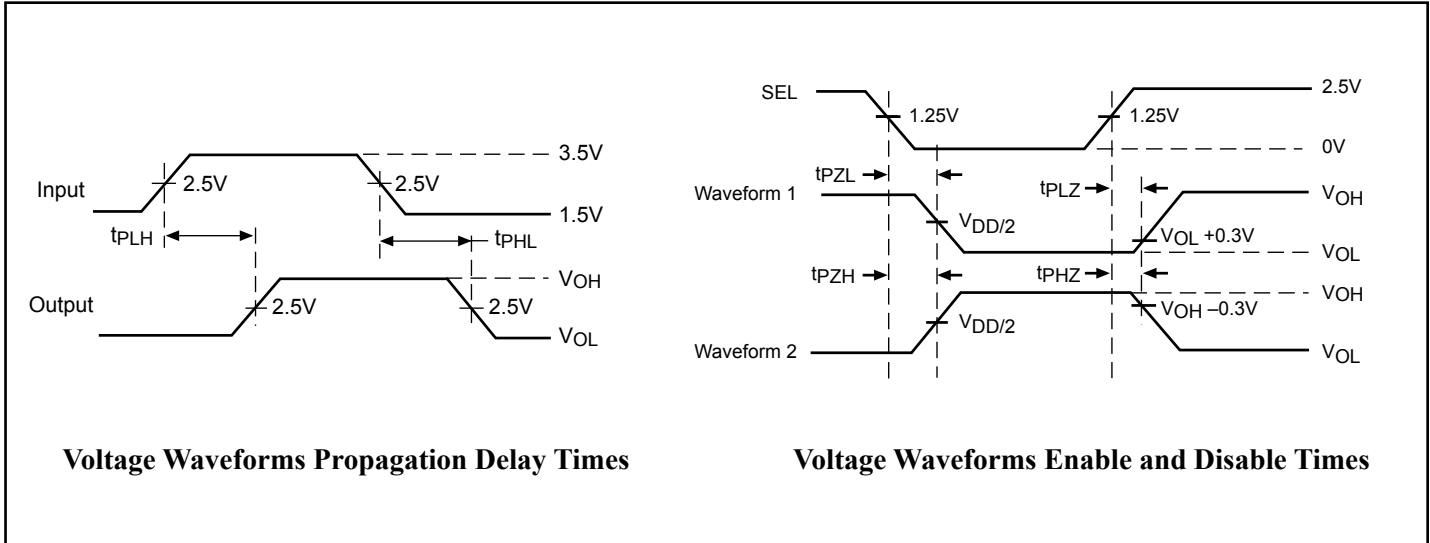

Test Circuits and Timing Diagrams

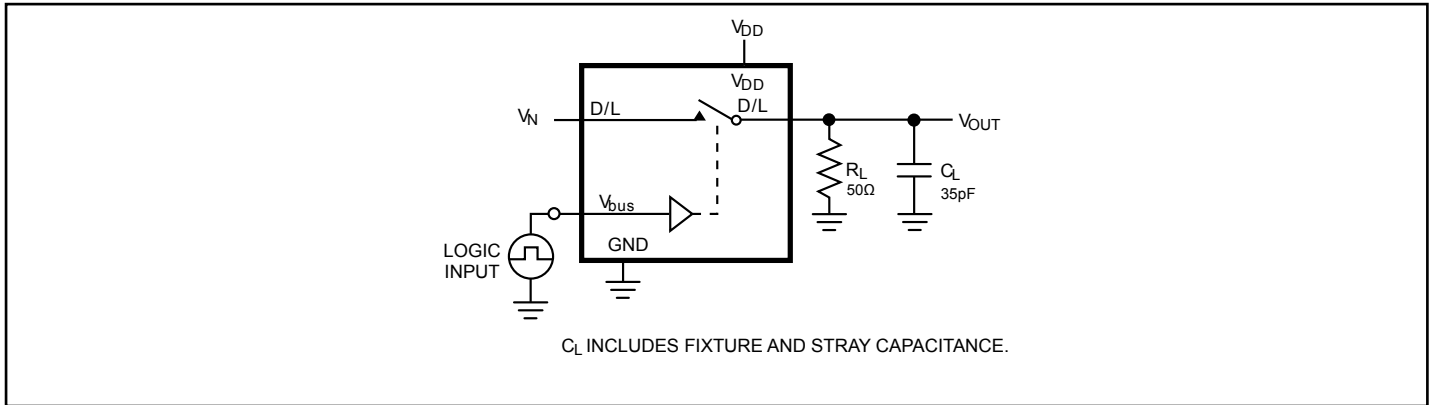

Figure 1. AC Test Circuit

Note:

1. Unused input (NC or NO) must be grounded.

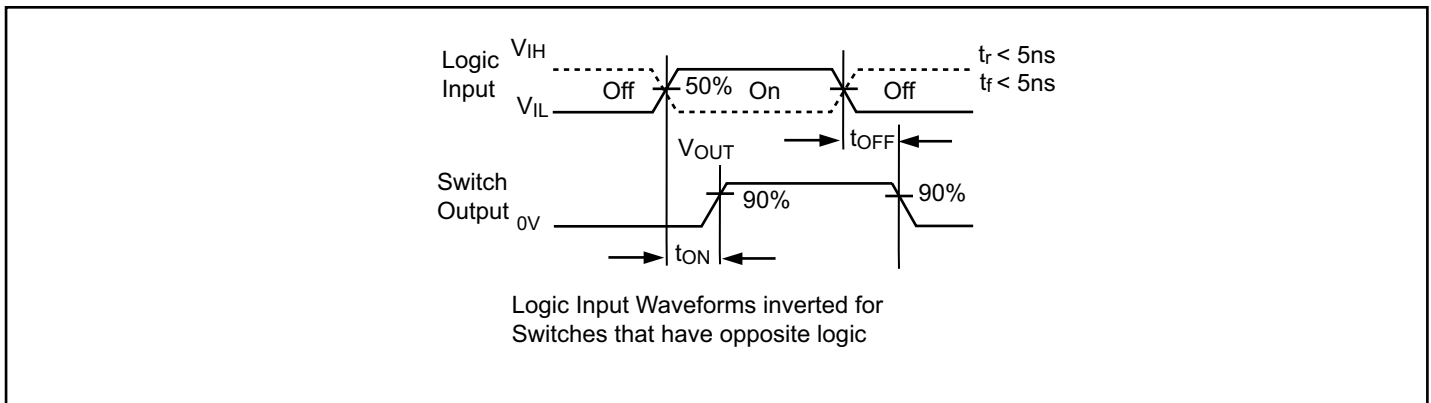

Figure 2. AC Waveforms

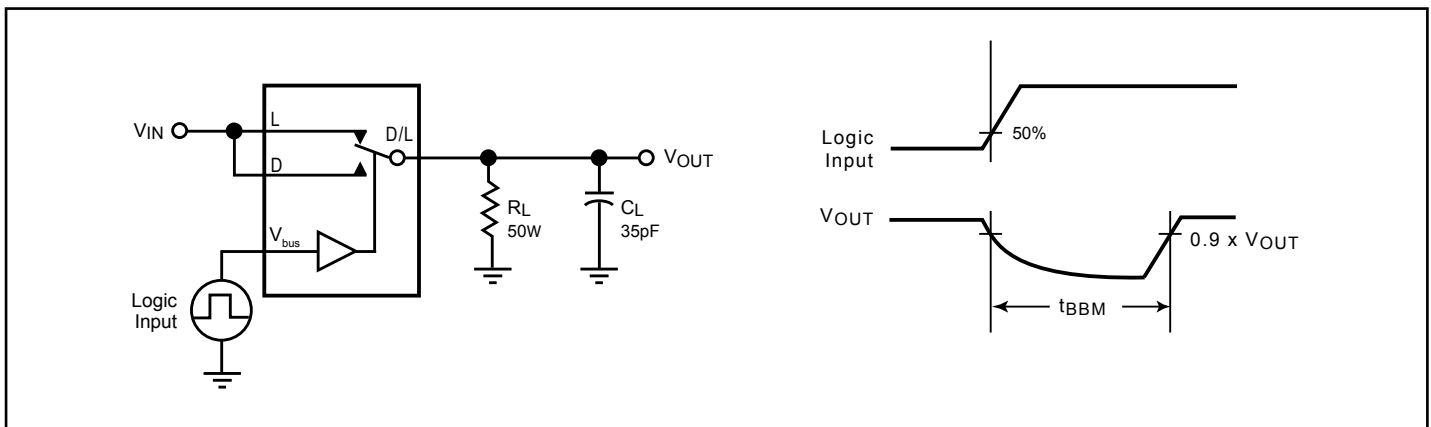

Figure 3. Break Before Make Interval Timing

PI3USB223

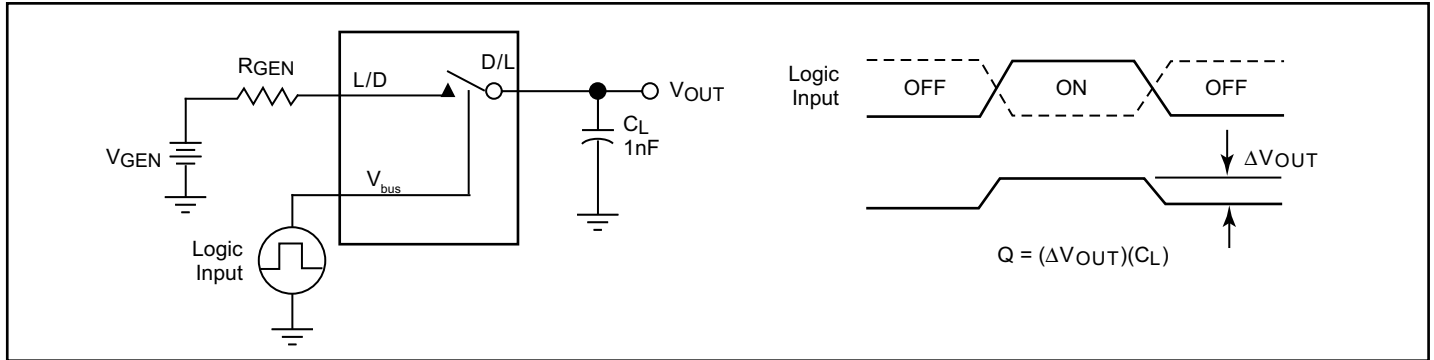

Figure 4. Charge Injection Test

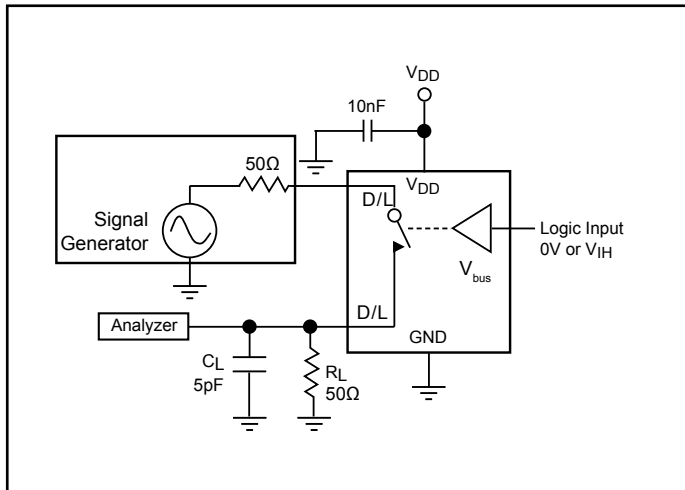

Figure 5. Off Isolation

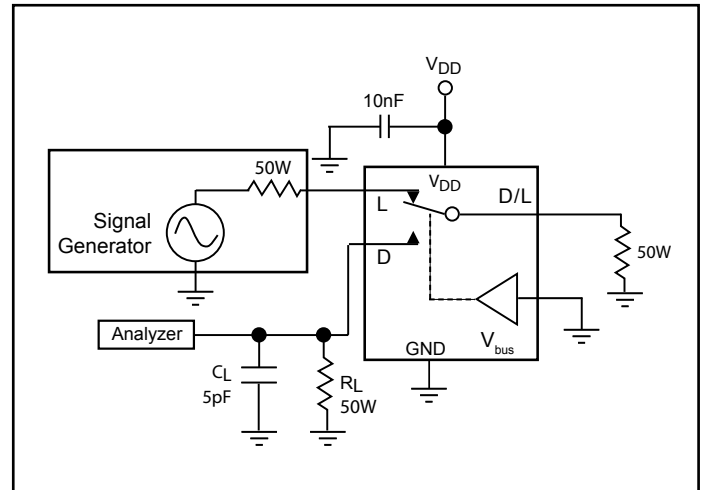

Figure 6. Crosstalk

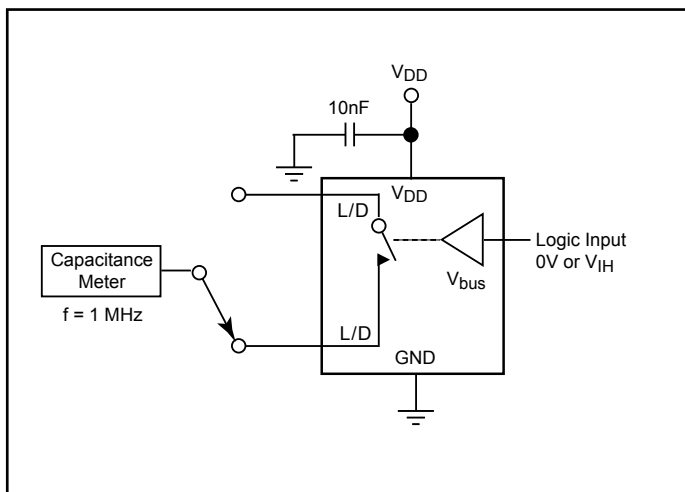

Figure 7. Channel Off Capacitance

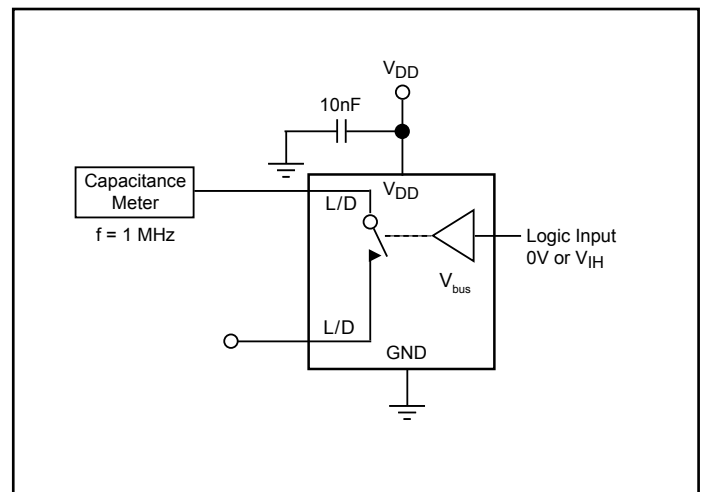

Figure 8. Channel On Capacitance

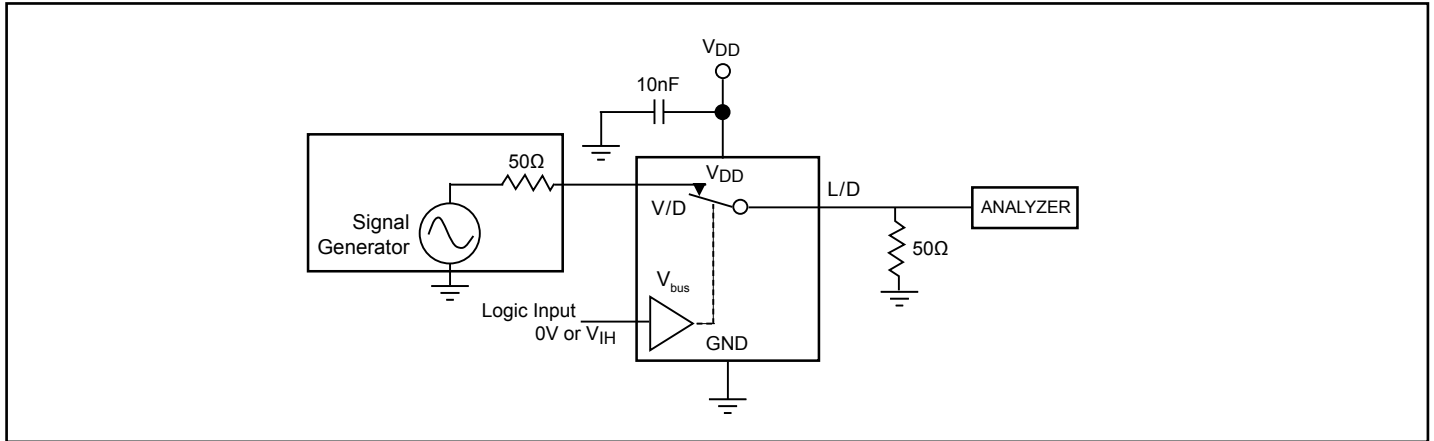

Figure 9. Bandwidth

Part Marking

ZM Package

Line above first character denotes
Lead-free and pin 1 indicator



RP: PI3USB223ZME

Y: Year

W: Workweek

Packaging Mechanical

10-UQFN (ZM)

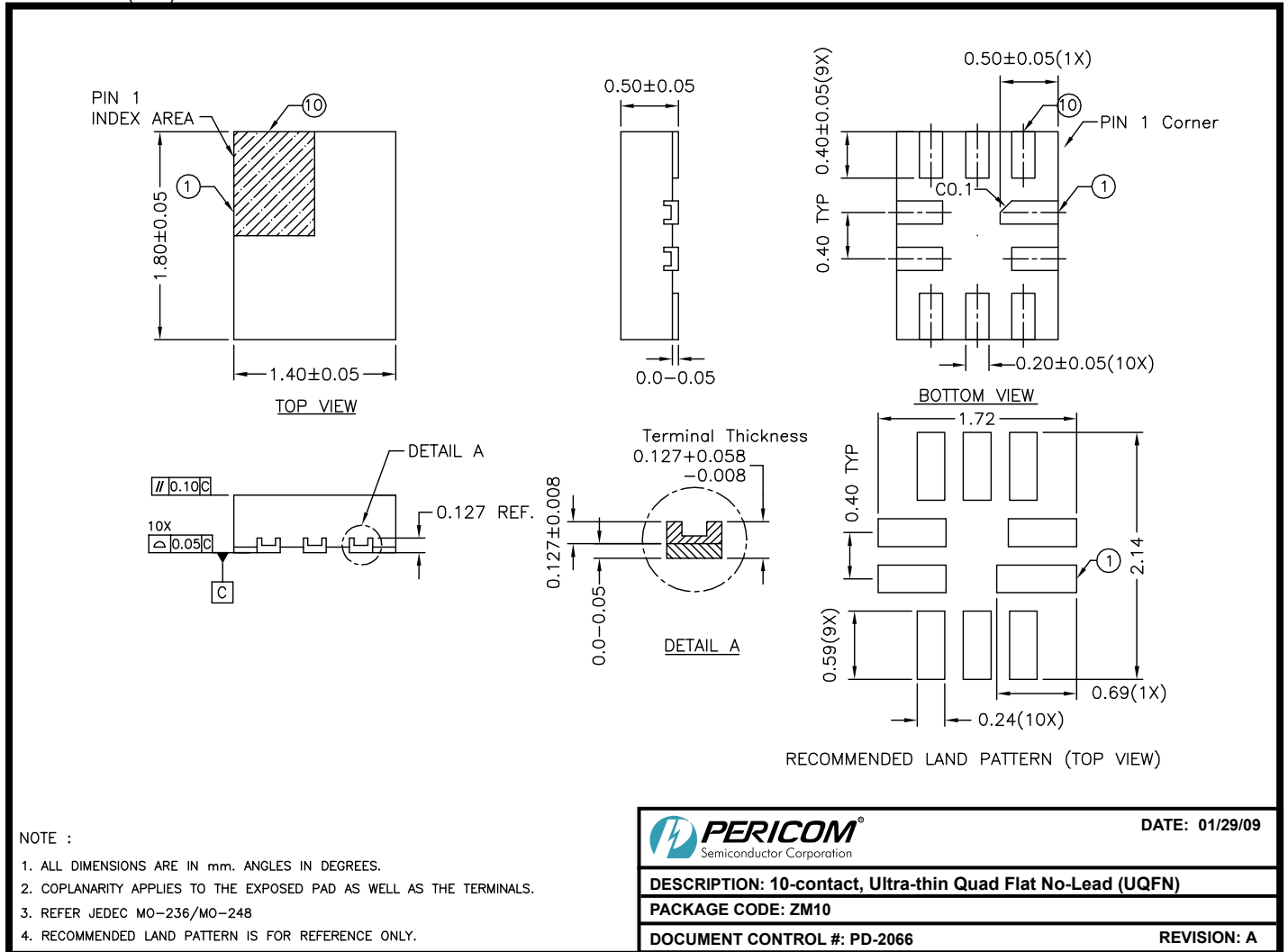

09-0072

For latest package info.

please check: <http://www.diodes.com/design/support/packaging/pericom-packaging/packaging-mechanicals-and-thermal-characteristics/>

Ordering Information

Ordering Code	Package Code	Description	Top Mark
PI3USB223ZMEX	ZM	10-contact, Ultra-thin Quad Flat No-Lead (UQFN)	RP

Notes:

1. No purposely added lead. Fully EU Directive 2002/95/EC (RoHS), 2011/65/EU (RoHS 2) & 2015/863/EU (RoHS 3) compliant.
2. See <https://www.diodes.com/quality/lead-free/> for more information about Diodes Incorporated's definitions of Halogen- and Antimony-free, "Green" and Lead-free.
3. Halogen- and Antimony-free "Green" products are defined as those which contain <900ppm bromine, <900ppm chlorine (<1500ppm total Br + Cl) and <1000ppm antimony compounds.
4. E = Pb-free and Green
5. X suffix = Tape/Reel

IMPORTANT NOTICE

DIODES INCORPORATED MAKES NO WARRANTY OF ANY KIND, EXPRESS OR IMPLIED, WITH REGARDS TO THIS DOCUMENT, INCLUDING, BUT NOT LIMITED TO, THE IMPLIED WARRANTIES OF MERCHANTABILITY AND FITNESS FOR A PARTICULAR PURPOSE (AND THEIR EQUIVALENTS UNDER THE LAWS OF ANY JURISDICTION).

Diodes Incorporated and its subsidiaries reserve the right to make modifications, enhancements, improvements, corrections or other changes without further notice to this document and any product described herein. Diodes Incorporated does not assume any liability arising out of the application or use of this document or any product described herein; neither does Diodes Incorporated convey any license under its patent or trademark rights, nor the rights of others. Any Customer or user of this document or products described herein in such applications shall assume all risks of such use and will agree to hold Diodes Incorporated and all the companies whose products are represented on Diodes Incorporated website, harmless against all damages.

Diodes Incorporated does not warrant or accept any liability whatsoever in respect of any products purchased through unauthorized sales channel.

Should Customers purchase or use Diodes Incorporated products for any unintended or unauthorized application, Customers shall indemnify and hold Diodes Incorporated and its representatives harmless against all claims, damages, expenses, and attorney fees arising out of, directly or indirectly, any claim of personal injury or death associated with such unintended or unauthorized application.

Products described herein may be covered by one or more United States, international or foreign patents pending. Product names and markings noted herein may also be covered by one or more United States, international or foreign trademarks.

This document is written in English but may be translated into multiple languages for reference. Only the English version of this document is the final and definitive format released by Diodes Incorporated.

LIFE SUPPORT

Diodes Incorporated products are specifically not authorized for use as critical components in life support devices or systems without the express written approval of the Chief Executive Officer of Diodes Incorporated. As used herein:

A. Life support devices or systems are devices or systems which:

1. are intended to implant into the body, or

2. support or sustain life and whose failure to perform when properly used in accordance with instructions for use provided in the labeling can be reasonably expected to result in significant injury to the user.

B. A critical component is any component in a life support device or system whose failure to perform can be reasonably expected to cause the failure of the life support device or to affect its safety or effectiveness.

Customers represent that they have all necessary expertise in the safety and regulatory ramifications of their life support devices or systems, and acknowledge and agree that they are solely responsible for all legal, regulatory and safety-related requirements concerning their products and any use of Diodes Incorporated products in such safety-critical, life support devices or systems, notwithstanding any devices- or systems-related information or support that may be provided by Diodes Incorporated. Further, Customers must fully indemnify Diodes Incorporated and its representatives against any damages arising out of the use of Diodes Incorporated products in such safety-critical, life support devices or systems.

Copyright © 2016, Diodes Incorporated

www.diodes.com