

EV-VNH7040AY Evaluation Board

Data brief



connect the load, the power supply and the microcontroller without any additional effort in external component design and connection.

VNH7040AY is a full bridge motor driver intended for a wide range of automotive applications. The device incorporates a dual monolithic high-side driver and two low-side switches. Both switches are designed using ST proprietary VIPower[®] M0 technology that allows to efficiently integrate on the same die a true Power MOSFET with an intelligent signal/protection circuitry. The three dies are assembled in a PowerSSO-36 package equipped with three exposed islands for optimized dissipation performances.

This package is specifically designed for the harsh automotive environment and offers improved thermal performance thanks to exposed die pads. A Multisense_EN pin is available to enable the MultiSense diagnostic. The input signals INA and INB can directly interface the microcontroller to select the motor direction and the brake condition. Two selection pins (SEL0 and SEL1) are available to address the information available on the Multisense to the microcontroller. The Multisense pin allows to monitor the motor current by delivering a current proportional to the motor current value and also provides the diagnostic feedback. The PWM, up to 20 KHz, allows to control the speed of the motor in all possible conditions.

Features

Parameter	Symbol	Value	Unit
Max transient supply voltage	V _{CC}	38	V
Operating voltage range	V _{CC}	4 to 28	V
Typ. on-state resistance (per Ch)	R _{ON}	40	mΩ
Current limitation (typ)	I _{LIMH}	35	A
Stand-by current (max)	I _{STBY}	1	μA

- Simple single IC application board dedicated for VNH7040AY
- Provides electrical connectivity and thermal heat-sinking for easy prototyping

Description

EV-VNH7040AY provides you an easy way to connect ST VIPower M0-7 HBridge drivers into your existing prototype circuitry. This evaluation board comes preassembled with VNH7040AY H-Bridge. The on-board minimum set of electrical components (as for device datasheet recommendation) enables the user to directly

Table 1. Device summary

Order Code	Reference
EV-VNH7040AY	VNH7040AY Evaluation Board

1 Design recommendation

This evaluation board provides mounting and some heat sinking capability for prototype development.

Figure 1. VNH7040AY evaluation board schematic

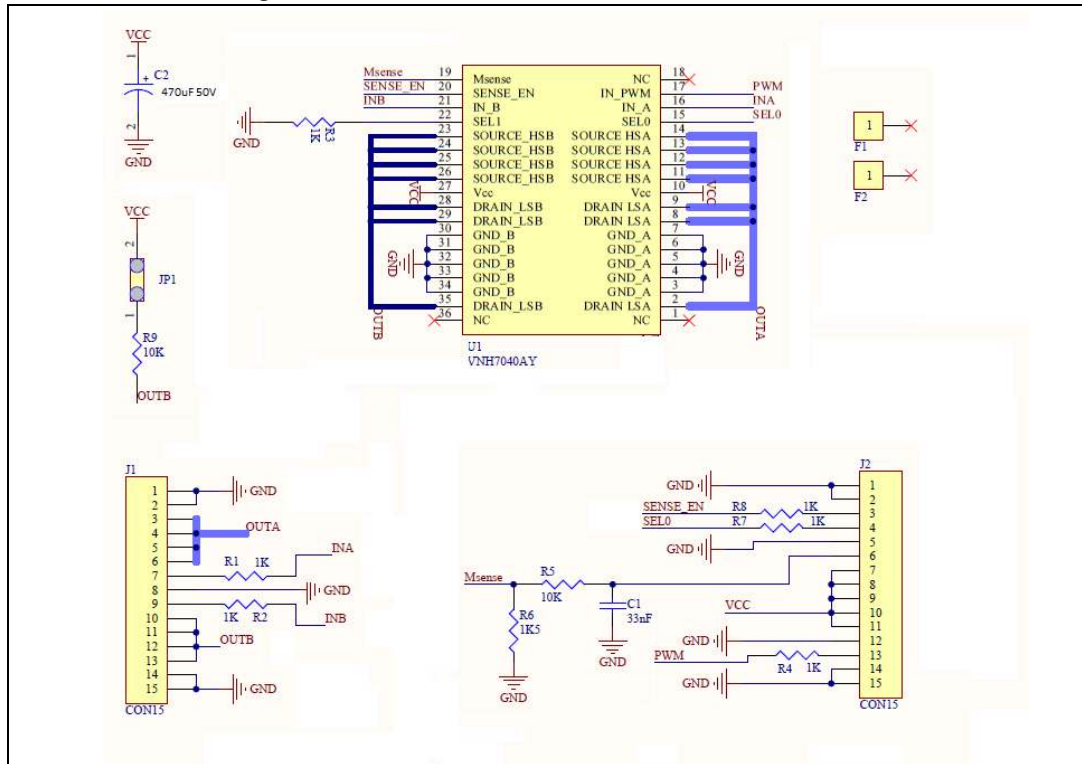

Figure 2. VNH7040AY evaluation board top layout

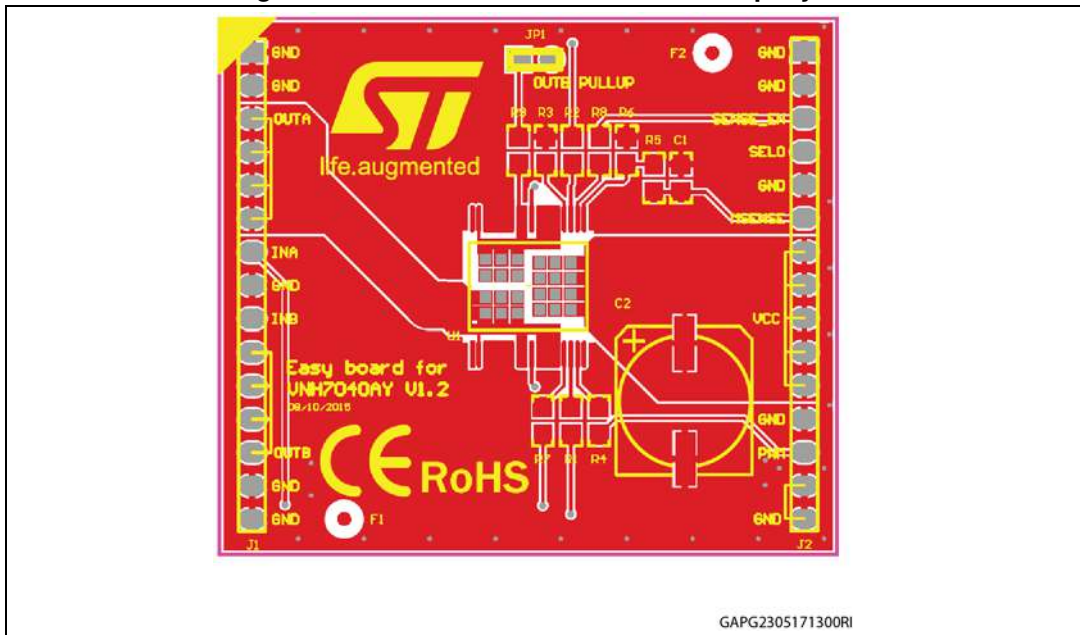
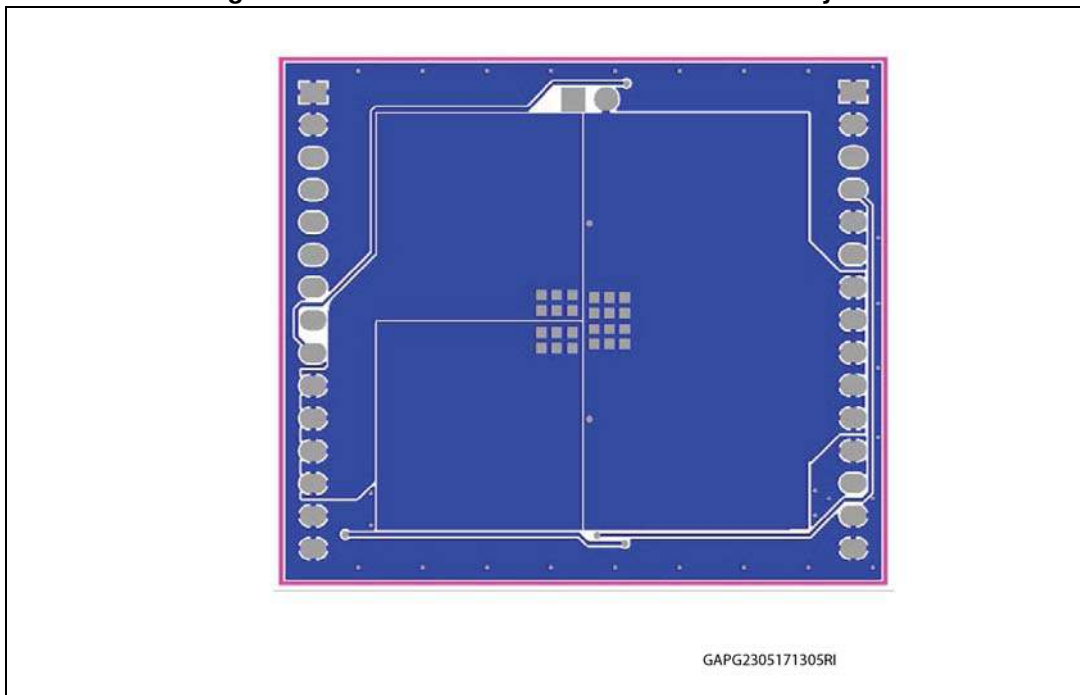

Figure 3. VNH7040AY evaluation board bottom layout



2 Board connections

Table 2. Pin connection and function

Connector	Board lead number	Device pin function
J1	1, 2	GND
J1	3, 4, 5, 6	OUTA
J1	7	INA
J1	8	GND
J1	9	INB
J1	10, 11, 12, 13	OUTB
J1	14, 15	GND
J2	1, 2	GND
J2	3	SENSE_EN
J2	4	SELO
J2	5	GND
J2	6	M_SENSE
J2	7, 8, 9, 10, 11	VCC
J2	12	GND
J2	13	PWM
J2	14, 15	GND

Table 3. BOM

Component	Value
C1	33 nF
C2	470 uF 50V
R1, R2,R3, R4, R7, R8	1K Ohm
R5, R9	10K Ohm
R6	1.5k Ohm

3 Thermal data

Table 4. EV-VNH7040AY thermal data

Symbol	Parameter	Max	Unit
Rthj-amb	Thermal resistance junction-ambient HSD (MAX)	40	°C/W
Rthj-amb	Thermal resistance junction-ambient LSD (MAX)	45	°C/W

Table 5. PCB specifications

Parameter	Value	Unit
Board dimensions	41 x 47	mm
Number of Cu layer	2	-
Layer Cu thickness	35	µm
Board finish thickness	1.6 +/- 10%	mm
Board Material	FR4	-
Thermal vias separation	1.1 mm	
Thermal vias diameter	0.5 mm	

4 ECOPACK®

In order to meet environmental requirements, ST offers these devices in different grades of ECOPACK® packages, depending on their level of environmental compliance. ECOPACK® specifications, grade definitions and product status are available at: www.st.com. ECOPACK® is an ST trademark.

5 Revision history

Table 6. Document revision history

Date	Revision	Changes
06-Jun-2017	1	Initial release.

IMPORTANT NOTICE – PLEASE READ CAREFULLY

STMicroelectronics NV and its subsidiaries ("ST") reserve the right to make changes, corrections, enhancements, modifications, and improvements to ST products and/or to this document at any time without notice. Purchasers should obtain the latest relevant information on ST products before placing orders. ST products are sold pursuant to ST's terms and conditions of sale in place at the time of order acknowledgement.

Purchasers are solely responsible for the choice, selection, and use of ST products and ST assumes no liability for application assistance or the design of Purchasers' products.

No license, express or implied, to any intellectual property right is granted by ST herein.

Resale of ST products with provisions different from the information set forth herein shall void any warranty granted by ST for such product.

ST and the ST logo are trademarks of ST. All other product or service names are the property of their respective owners.

Information in this document supersedes and replaces information previously supplied in any prior versions of this document.

© 2017 STMicroelectronics – All rights reserved