

### FEATURES

**Pin-Compatible with Industry Standard AD9803**  
**18 MSPS Correlated Double Sampler (CDS)**  
**Low Noise PGA with 0 dB to 34 dB Gain Range**  
**Low Noise Clamp Circuits**  
**Analog Preblanking Function**  
**10-Bit 18 MSPS A/D Converter**  
**AUX Input with Input Clamp and PGA**  
**Direct ADC Input with Input Clamp**  
**AUXMID Input with PGA**  
**3-Wire Serial Interface for Digital Control**  
**Two Auxiliary 8-Bit DACs**  
**3 V Single Supply Operation**  
**Low Power: 65 mW @ 2.7 V Supply**  
**48-Lead LQFP Package**

### APPLICATIONS

**Camcorders (8 mm and DVC)**  
**Digital Still Cameras**

### PRODUCT DESCRIPTION

The AD9806 is a complete analog signal processor for CCD applications. It features an 18 MHz single-channel architecture designed to sample and condition the outputs of interlaced and progressive scan area CCD arrays. The AD9806's signal chain consists of an input clamp, correlated double sampler (CDS), digitally programmable gain amplifier (PGA), black level clamp, and 10-bit A/D converter. Additional input modes are provided for processing analog video signals.

The internal registers are programmed through a 3-wire serial digital interface. Programmable features include gain adjustment, black level adjustment, input configuration, and power-down modes.

The AD9806 operates from a single 3 V power supply, typically dissipating 75 mW. Packaged in a space-saving 48-lead LQFP, the AD9806 is specified over an operating temperature range of  $-20^{\circ}\text{C}$  to  $+85^{\circ}\text{C}$ .

### FUNCTIONAL BLOCK DIAGRAM

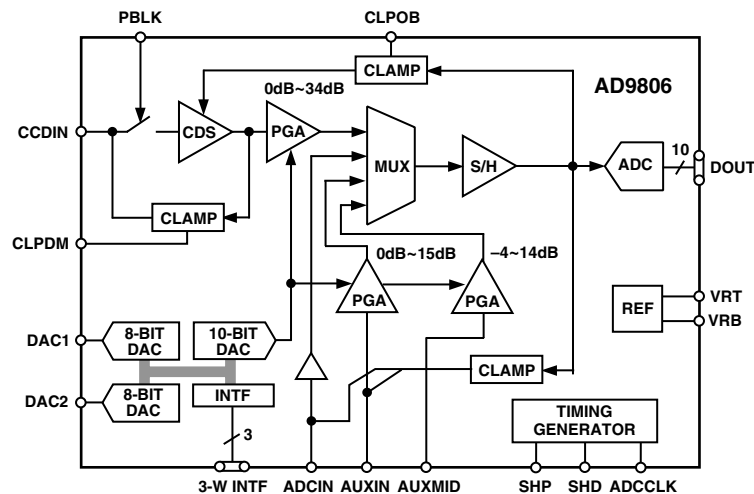

REV. 0

Information furnished by Analog Devices is believed to be accurate and reliable. However, no responsibility is assumed by Analog Devices for its use, nor for any infringements of patents or other rights of third parties which may result from its use. No license is granted by implication or otherwise under any patent or patent rights of Analog Devices.

# AD9806—SPECIFICATIONS

## GENERAL SPECIFICATIONS ( $T_{MIN}$ to $T_{MAX}$ , $AVDD = DVDD = 3.0\text{ V}$ , $f_{ADCCLK} = 18\text{ MHz}$ , unless otherwise noted.)

Parameter	Min	Typ	Max	Unit
TEMPERATURE RANGE				
Operating	-20		+85	°C
Storage	-65		+150	°C
POWER SUPPLY VOLTAGE (For Functional Operation) Analog, Digital, Digital Driver	2.7		3.6	V
POWER CONSUMPTION (Selected through Serial Interface D-Reg) Normal Operation (D-Reg 00) High-Speed AUX Mode (D-Reg 01) Reference Standby (D-Reg 10) Total Shut-Down Mode (D-Reg 11)		(Specified Under Each Mode of Operation) (Specified Under AUX-Mode) 5 1		mW mW
MAXIMUM CLOCK RATE	(Specified Under Each Mode of Operation)			MHz
A/D CONVERTER				
Resolution	10			Bits
Differential Nonlinearity (DNL)		±0.5	±1.0	LSB
No Missing Codes	GUARANTEED			
Full-Scale Input Voltage		1.0		V
VOLTAGE REFERENCE				
Reference Top Voltage (VRT)		2.0		V
Reference Bottom Voltage (VRB)		1.0		V

Specifications subject to change without notice.

## DIGITAL SPECIFICATIONS ( $DRVDD = 2.7\text{ V}$ , $C_L = 20\text{ pF}$ .)

Parameter	Symbol	Min	Typ	Max	Unit
LOGIC INPUTS					
High Level Input Voltage	$V_{IH}$	2.1			V
Low Level Input Voltage	$V_{IL}$			0.6	V
High Level Input Current	$I_{IH}$		10		μA
Low Level Input Current	$I_{IL}$		10		μA
Input Capacitance	$C_{IN}$		10		pF
LOGIC OUTPUTS					
High Level Output Voltage ( $I_{OH} = 2\text{ mA}$ )	$V_{OH}$	2.2			V
Low Level Output Voltage ( $I_{OL} = 2\text{ mA}$ )	$V_{OL}$			0.5	V
SERIAL INTERFACE TIMING (Figure 7)					
Maximum SCLK Frequency		10			MHz
SDATA to SCLK Setup	$t_{DS}$	10			ns
SCLK to SDATA Hold	$t_{DH}$	10			ns
SLOAD to SCLK Setup	$t_{LS}$	10			ns
SCLK to SLOAD Hold	$t_{LH}$	10			ns

Specifications subject to change without notice.

## CCD-MODE SPECIFICATIONS ( $T_{MIN}$ to $T_{MAX}$ , $AVDD = DVDD = 3.0$ V, $f_{ADCCLK} = f_{SHP} = f_{SHD} = 18$ MHz, unless otherwise noted.)

Parameter	Min	Typ	Max	Unit
<b>POWER CONSUMPTION</b>				
$V_{DD} = 2.7$		65		mW
$V_{DD} = 3.0$		75		mW
$V_{DD} = 3.3$		85		mW
<b>MAXIMUM CLOCK RATE</b>	18			MHz
<b>CDS</b>				
Gain		0		dB
Allowable CCD Reset Transient <sup>1</sup>		500		mV
Max Input Range before Saturation <sup>1</sup>	1000			mV p-p
<b>PGA</b>				
Gain Control Resolution		10		Bits
Gain Range (See Figure 5a for Gain Curve)				
Low Gain (Code 95) <sup>2</sup>	-1	0	+1	dB
Max Gain (1023) <sup>2</sup>	32	33	34	dB
<b>BLACK LEVEL CLAMP</b>				
Clamp Level (Selected through Serial Interface E-Reg)				
CLP0 (E-Reg 00)		32		LSB
CLP1 (E-Reg 01)		48		LSB
CLP2 (E-Reg 10)		64		LSB
CLP3 (E-Reg 11)		16		LSB
<b>SIGNAL-TO-NOISE RATIO<sup>3</sup> (@ Low PGA Gain)</b>		74		dB
<b>TIMING SPECIFICATIONS<sup>4</sup></b>				
Pipeline Delay		9		Cycles
Internal Clock Delay <sup>5</sup> ( $t_{ID}$ )		3		ns
Inhibited Clock Period ( $t_{INHIBIT}$ )	10			ns
Output Delay ( $t_{OD}$ )		14.5	16	ns
Output Hold Time ( $t_{HOLD}$ )	6			ns
ADCCLK, SHP, SHD Clock Period	47	55.6		ns
ADCCLK High-Level/Low-Level	20	28		ns
SHP, SHD Minimum Pulswidth	10	14		ns
SHP Rising Edge to SHD Rising Edge	20	28		ns

## NOTES

<sup>1</sup>Input signal characteristics defined as follows:

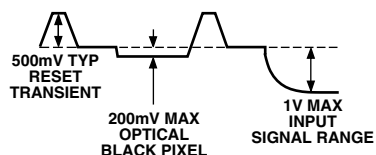

<sup>2</sup>Use equations on page 8 to calculate gain.

<sup>3</sup> $SNR = 20 \log_{10}$  (Full-Scale Voltage/RMS Output Noise).

<sup>4</sup>20 pF loading; timing shown in Figure 1.

<sup>5</sup>Internal aperture delay for actual sampling edge.

Specifications subject to change without notice.

# AD9806—SPECIFICATIONS

## AUX-MODE SPECIFICATIONS ( $T_{MIN}$ to $T_{MAX}$ , $AVDD = DVDD = 3.0\text{ V}$ , $f_{ADCCLK} = 18\text{ MHz}$ , unless otherwise noted.)

Parameter	Min	Typ	Max	Unit
POWER CONSUMPTION				
Normal (D-Reg 00)		50		mW
High-Speed (D-Reg 01)		95		mW
MAXIMUM CLOCK RATE				
Normal (D-Reg 00)	18			MHz
High-Speed (D-Reg 01)	28.6			MHz
PGA (Gain Selected through Serial Interface F-Reg)				
Max Input Range	700			mV p-p
Max Output Range	1000			mV p-p
Gain Control Resolution		7		Bits
Gain Range				
Min Gain (Code 128)		-2		dB
Max Gain (Code 255)		15		dB
ACTIVE CLAMP				
Clamp Level (Selected through Serial Interface E-Reg)				
CLP0 (E-Reg 00)		32		LSB
CLP1 (E-Reg 01)		48		LSB
CLP2 (E-Reg 10)		64		LSB
CLP3 (E-Reg 11)		16		LSB
TIMING SPECIFICATIONS <sup>1</sup>				
Pipeline Delay		9		Cycles
Internal Clock Delay ( $t_{ID}$ )				
Output Delay ( $t_{OD}$ )		14.5	16	ns
Output Hold Time ( $t_{HOLD}$ )	7			ns

### NOTES

<sup>1</sup>20 pF loading; timing shown in Figure 2.

Specifications subject to change without notice.

## AUXMID-MODE SPECIFICATIONS ( $T_{MIN}$ to $T_{MAX}$ , $AVDD = DVDD = 3.0\text{ V}$ , $f_{ADCCLK} = 18\text{ MHz}$ , unless otherwise noted.)

Parameter	Min	Typ	Max	Unit
POWER CONSUMPTION		50		mW
MAXIMUM CLOCK RATE	18			MHz
PGA (Gain Selected through Serial Interface F-Reg)				
Max Input Range	700			mV p-p
Max Output Range	1000			mV p-p
Gain Control Resolution		9		Bits
Gain Range (See Figure 5b for Gain Curve)				
Min Gain (Code 512)		-4		dB
Max Gain (Code 1023)		14		dB
MIDSCALE OFFSET LEVEL (AT MAX PGA GAIN)	462	512	562	LSB
TIMING SPECIFICATIONS <sup>1</sup>				
Pipeline Delay		9		Cycles
Internal Clock Delay ( $t_{ID}$ )				
Output Delay ( $t_{OD}$ )		14.5	16	ns
Output Hold Time ( $t_{HOLD}$ )	7			ns

### NOTES

<sup>1</sup>20 pF loading; timing shown in Figure 2.

Specifications subject to change without notice.

**ADC-MODE SPECIFICATIONS** ( $T_{\text{MIN}}$  to  $T_{\text{MAX}}$ ,  $AVDD = DVDD = 3.0\text{ V}$ ,  $f_{\text{ADCCLK}} = 18\text{ MHz}$ , unless otherwise noted.)

Parameter	Min	Typ	Max	Unit
POWER CONSUMPTION		(Same as AUX-MODE)		
MAXIMUM CLOCK RATE		(Same as AUX-MODE)		
ACTIVE CLAMP		(Same as AUX-MODE)		
TIMING SPECIFICATIONS <sup>1</sup>		(Same as AUX-MODE)		

Specifications subject to change without notice.

**DAC SPECIFICATIONS (DAC1 and DAC2)**

Parameter	Min	Typ	Max	Unit
RESOLUTION		8		Bits
MIN OUTPUT		0.1		V
MAX OUTPUT		VDD – 0.1		V
MAX CURRENT LOAD		1		mA
MAX CAPACITIVE LOAD		500		pF

Specifications subject to change without notice.

**ABSOLUTE MAXIMUM RATINGS**

Parameter	With Respect To	Min	Max	Unit
AVDD1, AVDD2	AVSS	-0.3	+3.9	V
DVDD1, DVDD2	DVSS	-0.3	+3.9	V
DRVDD	DRVSS	-0.3	+3.9	V
Digital Outputs	DRVSS	-0.3	DRVDD + 0.3	V
SHP, SHD, DATACLK	DVSS	-0.3	DVDD + 0.3	V
CLPOB, CLPDM, PBLK	DVSS	-0.3	DVDD + 0.3	V
SCK, SL, SDATA	DVSS	-0.3	DVDD + 0.3	V
VRT, VRB, CMLEVEL	AVSS	-0.3	AVDD + 0.3	V
CCDIN, CLPOUT, CLPREF, CLPBYP	AVSS	-0.3	AVDD + 0.3	V
Junction Temperature			150	°C
Lead Temperature (10 sec)			300	°C

**ORDERING GUIDE**

Model	Temperature Range	Package Description	Package Option
AD9806KST	-20°C to +85°C	Thin Plastic Quad Flatpack (LQFP)	ST-48

**THERMAL CHARACTERISTICS****Thermal Resistance**

48-Lead LQFP Package

$$\theta_{JA} = 92^{\circ}\text{C}$$

**CAUTION**

ESD (electrostatic discharge) sensitive device. Electrostatic charges as high as 4000 V readily accumulate on the human body and test equipment and can discharge without detection. Although the AD9806 features proprietary ESD protection circuitry, permanent damage may occur on devices subjected to high-energy electrostatic discharges. Therefore, proper ESD precautions are recommended to avoid performance degradation or loss of functionality.



## PIN CONFIGURATION

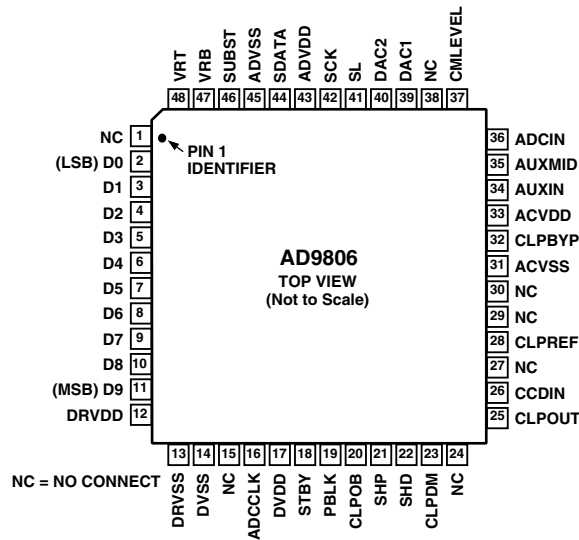

## PIN FUNCTION DESCRIPTIONS

Pin No.	Mnemonic	Type	Description (See Figures 10 and 11 for Circuit Configurations)
1, 15, 24	NC		No Connect (Should be Left Floating or Tied to Ground)
2–11	D0–D9	DO	Digital Data Outputs
12	DRVDD	P	Digital Driver Supply (3 V)
13	DRVSS	P	Digital Driver Ground
14	DVSS	P	Digital Ground
16	ADCCLK	DI	ADC Sample Clock Input
17	DVDD	P	Digital Supply (3 V)
18	STBY	DI	Power-Down Mode (Active High/Internal Pull-Down). Enables Reference Standby Mode.
19	PBLK	DI	Pixel Blanking
20	CLPOB	DI	Black Level Restore Clamp
21	SHP	DI	CCD Reference Sample Clock Input
22	SHD	DI	CCD Data Sample Clock Input
23	CLPDM	DI	Input Clamp
25	CLPOUT	AO	CDS Bypass (0.1 $\mu$ F to Ground)
26	CCDIN	AI	CDS Input Pin (Connect to CCD Input Signal through 0.1 $\mu$ F Capacitor)
27	NC		No Connect (Should Be Left Floating, or May Be Shorted to Pin 26)
28	CLPPREF	AO	CDS Bypass (0.1 $\mu$ F to Ground)
29, 30, 38	NC		No Connect (Should Be Left Floating, Tied to Ground, or Decoupled to Ground)
31	ACVSS	P	Analog Ground
32	CLPBYP	AO	CDS Bypass (0.1 $\mu$ F to Ground)
33	ACVDD	P	Analog Supply (3 V)
34	AUXIN	AI	AUX-MODE Input
35	AUXMID	AI	AUXMID-MODE Input
36	ADCIN	AI	ADC-MODE Input
37	CMLEVEL	AO	Common-Mode Level (0.1 $\mu$ F to Ground)
39	DAC1	AO	DAC1 Output
40	DAC2	AO	DAC2 Output
41	SL	DI	Serial I/F Load Signal
42	SCK	DI	Serial I/F Clock
43	ADVDD	P	Analog Supply (3 V)
44	SDATA	DI	Serial I/F Input Data
45	ADVSS	P	Analog Ground
46	SUBST	P	Analog Ground
47	VRB	AO	Bottom Reference (0.1 $\mu$ F to Ground and 1 $\mu$ F to VRT)
48	VRT	AO	Top Reference (0.1 $\mu$ F to Ground)

### NOTE

Type: AI = Analog Input, AO = Analog Output, DI = Digital Input, DO = Digital Output, P = Power.

TIMING SPECIFICATIONS

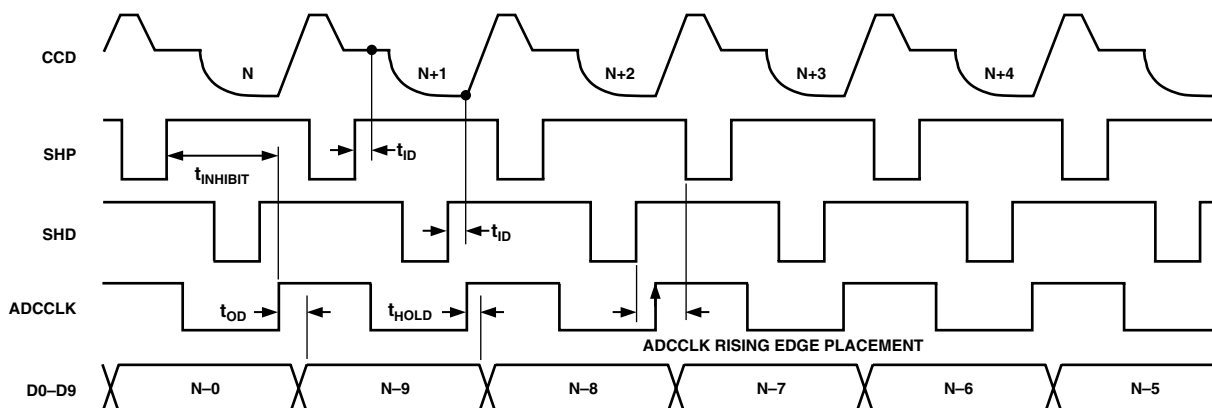

- NOTES:
1. SHP AND SHD SHOULD BE OPTIMALLY ALIGNED WITH THE CCD SIGNAL. SAMPLES ARE TAKEN AT THE RISING EDGES.
  2. ADCCLK RISING EDGE MUST OCCUR AT LEAST 15ns AFTER THE RISING EDGE OF SHP ( $t_{INHIBIT}$ ).
  3. RECOMMENDED PLACEMENT FOR ADCCLK RISING EDGE IS BETWEEN THE RISING EDGE OF SHD AND FALLING EDGE OF SHP.
  4. OUTPUT LATENCY IS 9 CYCLES.
  5. ACTIVE LOW CLOCK PULSE MODE IS SHOWN.

Figure 1. CCD-MODE Timing

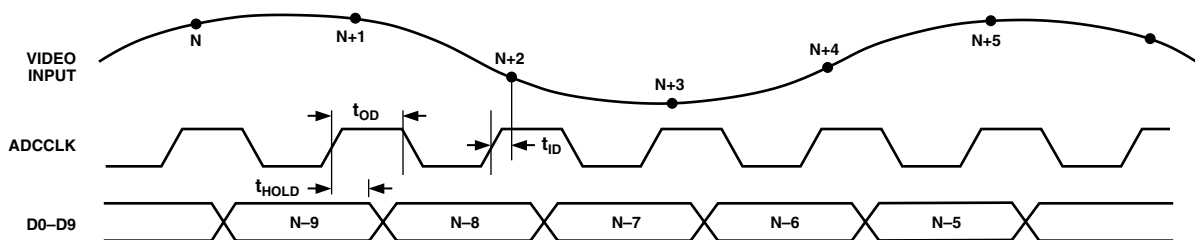

- NOTE:  
EXAMPLE OF OUTPUT DATA LATCHED BY ADCCLK RISING EDGE.

Figure 2. AUX-, AUXMID-, ADC-Mode Timing

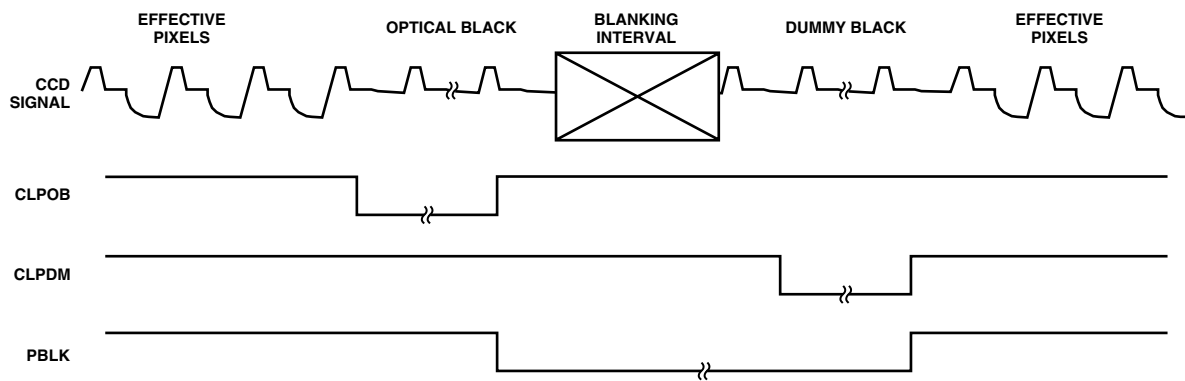

- NOTES:
1. CLPOB PULSEWIDTH SHOULD BE A MINIMUM OF 10 OB PIXELS WIDE, 20 OB PIXELS ARE RECOMMENDED.
  2. CLPDM PULSEWIDTH SHOULD BE AT LEAST 1 $\mu$ s WIDE.
  3. PBLK IS NOT REQUIRED, BUT RECOMMENDED IF THE CCD SIGNAL AMPLITUDE EXCEEDS 1V p-p.
  4. CLPDM OVERWRITES PBLK.
  5. ACTIVE LOW CLAMP PULSE MODE IS SHOWN.

Figure 3. CCD-MODE Clamp Timing

# AD9806

## TIMING SPECIFICATIONS (Continued)

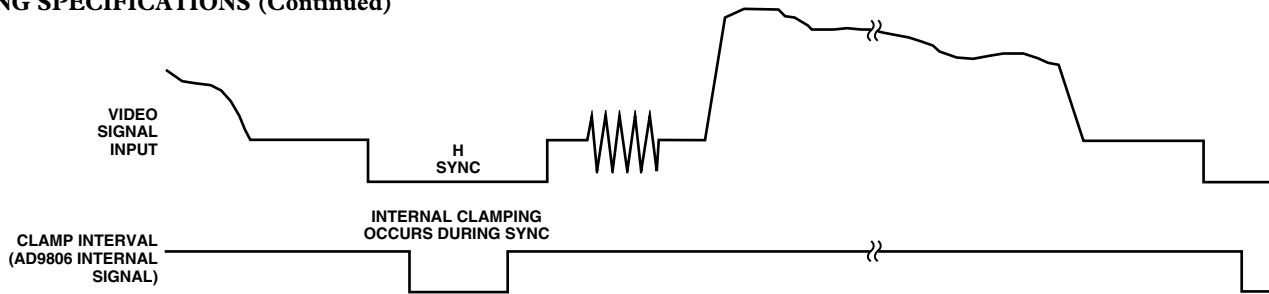

**NOTE:** The AD9806 uses an “automatic” video clamp that senses the most negative in the input signal and uses this level to set the clamp voltage. As shown in the video waveform above, the SYNC level will be clamped to the black level specified in the E-Register.

Figure 4. AUX-MODE and ADC-MODE Clamp Operation

### PGA GAIN CURVE DETAILS

In CCD-Mode, the AD9806 PGA stage provides a gain range of 0 dB to 34 dB, programmable with 10-bit resolution through the serial digital interface. The PGA gain curve is divided into two separate regions. When the PGA Gain Register code is between 0, and 511, the curve follows a  $(1 + x)/(1 - x)$  shape, which is similar to a “linear-in-dB” characteristic. From Code

512 to Code 1023, the curve follows a “linear-in-dB” shape. In AUXMID-Mode, the PGA provides a gain range of -4 dB to +14 dB, programmable with 9-bit resolution. The exact PGA gain for either mode can be calculated for any Gain Register value by using the following equations:

#### CCD-MODE

Code Range	Gain Equation (dB)
0–511	$Gain = 20 \log_{10} \left( \frac{[658 + code]}{[658 - code]} \right) - 2.4$
512–1023	$Gain = (0.0354)(code) - 2.4$

#### AUXMID-MODE

Code Range	Gain Equation (dB)
512–1023	$Gain = 20 \log_{10} \left( \frac{[146 + code]}{[1170 - code]} \right) - 4$

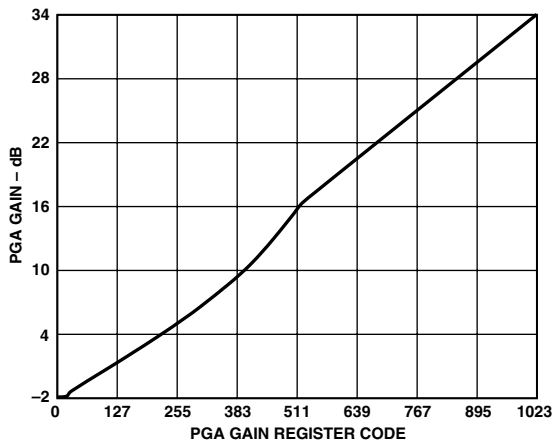

Figure 5a. PGA Gain Curve for CCD-Mode

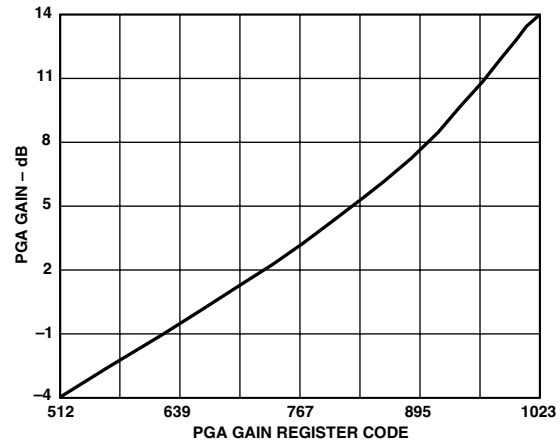

Figure 5b. PGA Gain Curve for AUXMID-Mode

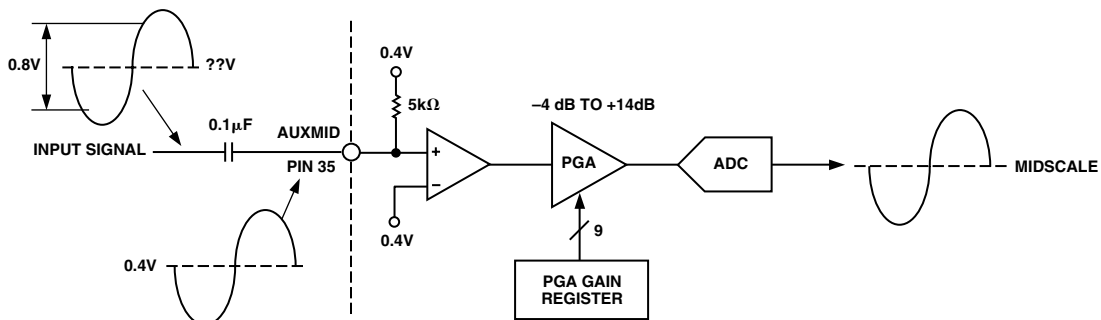
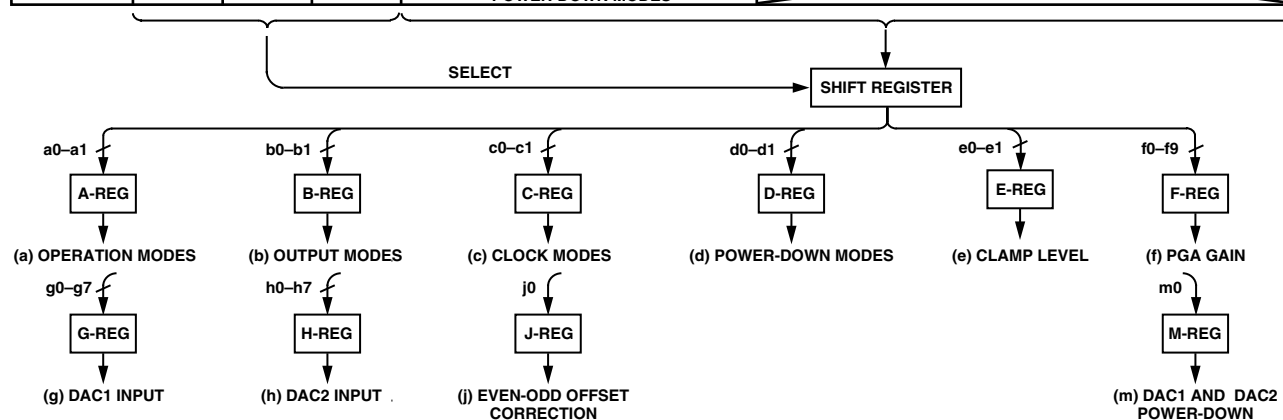

Figure 6. AUXMID-Mode Circuit Block Diagram



SERIAL INTERFACE SPECIFICATIONS

SDATA SELECT	A0	A1	A2	D0	D1	D2	D3	D4	D5	D6	D7	D8	D9
MODES	1	0	0	e0	e1	d0	d1	c0	c1	b0	b1	a0	a1
PGA	0	1	0	CLAMP LEVEL		POWER-DOWN MODES		CLOCK MODES		OUTPUT MODES		OPERATION MODES	
DAC1	1	1	0	f0	f1	f2	f3	f4	f5	f6	f7	f8	f9
DAC2	0	0	1	PGA GAIN LEVEL SELECTION									
MODES2 <sup>1</sup>	1	1	1	g0	g1	g2	g3	g4	g5	g6	g7		
				DAC1 INPUT									
				h0	h1	h2	h3	h4	h5	h6	h7		
				DAC2 INPUT									
				m0	0*	DON'T CARE	j0						
				OPERATION AND POWER-DOWN MODES									



\*NOTE: MODES2 REGISTER BIT D1 MUST BE SET TO ZERO

Figure 7. AD9806 Internal Register Map

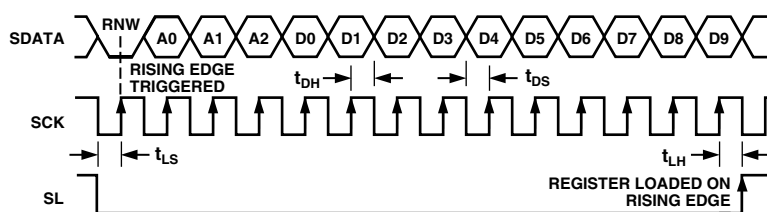

Figure 8. Serial WRITE Operation

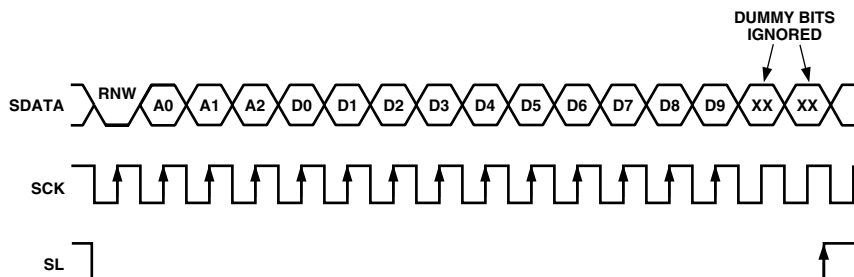

Figure 9. 16-Bit Serial WRITE Operation

# AD9806

## REGISTER DESCRIPTION

(a) **A-REGISTER: Modes of Operation** (Power-On Default Value = 11)

a1	a0	Modes
0	0	ADC-MODE
0	1	AUX-MODE
1	0	AUXMID-MODE
1	1	CCD-MODE

(b) **B-REGISTER: Output Modes** (Default = 00)

b1	b0	D9 D8 D7 D6 D5 D4 D3 D2 D1 D0
0	0	Normal
0	1	0 1 0 1 0 1 0 1 0 1
1	0	1 0 1 0 1 0 1 0 1 0
1	1	High Impedance

(c) **C-REGISTER: Clock Modes** (Default = 00)

c1	c0	SHP-SHD Clock Pulses	Clamp Active Pulses
0	0	Active Low	Active Low
0	1	Active Low	Active High
1	0	Active High	Active Low
1	1	Active High	Active High

(d) **D-REGISTER: Power-Down Modes** (Default = 00)

Modes	d1	d0	Description
Normal	0	0	Normal Operation
High Speed	0	1	High-Speed AUX/ADC-MODE
Power-Down1	1	0	Reference Stand-By (Same Mode as STBY Pin 18)
Power-Down2	1	1	Total Shut-Down

(e) **E-REGISTER: Clamp Level Selection** (Default = 00)

	e1	e0	Clamp Level
CLP (0)	0	0	32 LSBs
CLP (1)	0	1	48 LSBs
CLP (2)	1	0	64 LSBs
CLP (3)	1	1	16 LSBs

(f) **F-REGISTER: CCD-Mode PGA** (Default = 00 . . . 0)

	f9 f8 f7 f6 f5 f4 f3 f2 f1 f0	CCD-Gain
Gain (0)	0 0 0 0 0 0 0 0 0 0	Minimum
Gain (1023)	1 1 1 1 1 1 1 1 1 1	Maximum

(f) **F-REGISTER: AUXMID-Mode PGA** (Default = 00 . . . 0)

	f9 f8 f7 f6 f5 f4 f3 f2 f1 f0	AUXMID-Gain
Gain (512)	1 0 0 0 0 0 0 0 0 0	-4 dB
Gain (1023)	1 1 1 1 1 1 1 1 1 1	+14 dB

Only the 9 LSBs of F-REG are used to adjust gain.

(f) **F-REGISTER: AUX-Mode PGA** (Default = 00 . . . 0)

	f9 f8 f7 f6 f5 f4 f3 f2	AUX-Gain
Gain (128)	1 0 0 0 0 0 0 0	Minimum
Gain (255)	1 1 1 1 1 1 1 1	Maximum

(g) **G-REGISTER: DAC1 Input** (Default = 00 . . . 0)

	g7 g6 g5 g4 g3 g2 g1 g0	DAC1 Output
Code (0)	0 0 0 0 0 0 0 0	Minimum
Code (255)	1 1 1 1 1 1 1 1	Maximum

(h) **H-REGISTER: DAC2 Input** (Default = 00 . . . 0)

	h7 h6 h5 h4 h3 h2 h1 h0	DAC2 Output
Code (0)	0 0 0 0 0 0 0 0	Minimum
Code (255)	1 1 1 1 1 1 1 1	Maximum

(j) **J-REGISTER: Even-Odd Offset Correction** (Default = 0)

j0	Even-Odd Offset Correction
0	Offset Correction In Use
1	Offset Correction Not Used

(m) **M-REGISTER: DAC1 and DAC2 PDN** (Default = 0)

m0	Power-Down of 8-Bit DACs
0	8-Bit DACs Powered Down
1	8-Bit DACs Operational

NOTE: With the exception of a write to the PGA register during AUX-mode, all data writes must be 10 bits. During an AUX-mode write to the PGA register, only 8 bits of data are required. If more than 14 SCK rising edges are applied during a write operation, additional SCK pulses will be ignored (see Figure 9). All reads must be 10 bits to receive valid register contents. All registers default to 0s on power-up, except for the A-register which defaults to 11. Thus, on power-up, the AD9806 defaults to CCD mode with the 8-bit DACs powered down. During the power-up phase, it is recommended that SL be HIGH and SCK be LOW to prevent accidental register write operations. SDATA may be unknown. The RNW bit (“Read/Not Write”) must be LOW for all write operations to the serial interface, and HIGH when reading back from the serial interface registers.

## APPLICATION INFORMATION

### Grounding and Decoupling Recommendations

As shown in Figure 10, a single ground plane is recommended for the AD9806. This ground plane should be as continuous as possible, particularly around Pins 25 through 37. This will ensure that all analog decoupling capacitors provide the lowest possible impedance path between the power and bypass pins and their respective ground pins. All decoupling capacitors should be located as close as possible to the package pins. A single clean power supply is recommended for the AD9806, but a separate digital driver supply may be used for DRVDD (Pin 12). DRVDD should always be decoupled to DRVSS (Pin 13), which should be connected to the analog ground plane. The advantages of using a separate digital driver supply include using a lower voltage (2.7 V) to match levels with a 2.7 V ASIC, reducing digital power dissipation, and reducing potential noise coupling.

### Using the AD9806 in AD9803 Sockets

The AD9806 may be easily used in existing AD9803 designs without any circuit modifications. Most of the pin assignments are the same for both ICs. Table I outlines the differences. The circuit of Figure 10 shows the necessary connections for the AD9806 when used in an existing AD9803 socket. If the two auxiliary DACs are not used, then Pins 39 and 40 (DAC1 and DAC2) may be grounded. If the AUX or ADC modes are needed, then the input signal should be connected to either AUXIN or ADCIN through a 0.1  $\mu\text{F}$  capacitor, in the same way that CCDIN is used with the input signal.

Table I. AD9806/AD9803 Pin Differences

Pin No.	AD9803	AD9806	Circuit Connection
1	NC	NC	Ground
15	ACL P	NC	Ground
24	NC	NC	Ground
25	CCDBYP2	CLPOUT	Decoupled with 0.1 $\mu\text{F}$ to Ground
27	PIN	NC	Shorted to Pin 26
28	CCDBYP2	CLPREF	Decoupled with 0.1 $\mu\text{F}$ to Ground
29	PGABYP1	NC	Decoupled with 0.1 $\mu\text{F}$ to Ground
30	PGABYP2	NC	Shorted to Pin 29
35	AUXCONT	AUXMID	Ground, or decoupled with 0.1 $\mu\text{F}$ to Ground
38	VTRBYP	NC	Decoupled with 0.1 $\mu\text{F}$ to Ground

### Using the AD9806 in New Designs

Figure 11 shows the recommended circuit for using the AD9806 in new designs. Three external decoupling capacitors have been removed from the circuit shown in Figure 9, one from Pin 29, one from Pin 38, and one from between Pins 47 and 48. Note that the decoupling capacitors for Pins 47 (VRB) and 48 (VRT) must be increased to 1.0  $\mu\text{F}$  when used in this configuration.

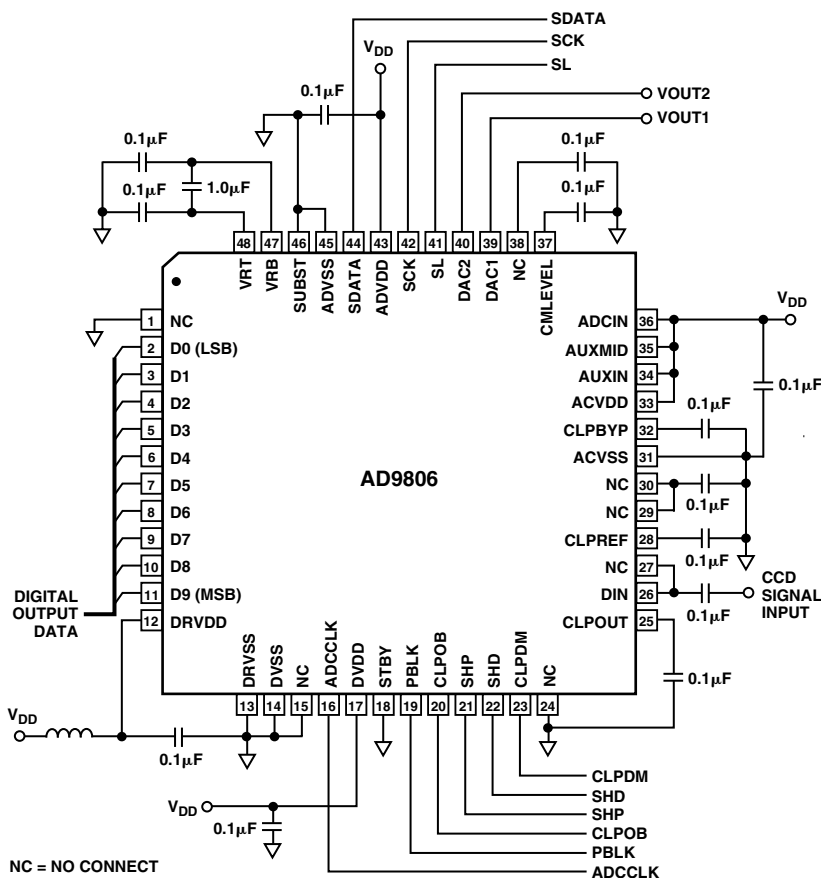

Figure 10. CCD-Mode Circuit Configuration Used in AD9803 Socket

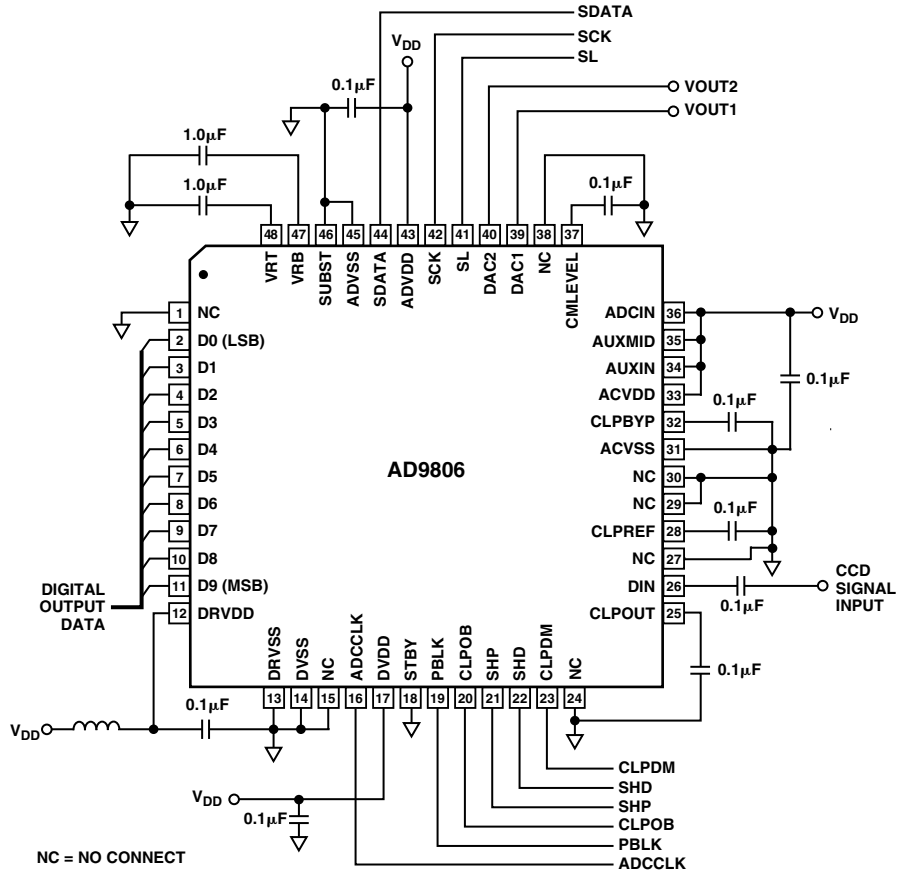

Figure 11. CCD-Mode Circuit Configuration Using Minimum External Components

OUTLINE DIMENSIONS

Dimensions shown in inches and (mm).

48-Lead, LQFP  
(ST-48)

