



# Microprocessor Voltage Monitors with Programmable Voltage Detection

MAX8211/MAX8212

## General Description

Maxim's MAX8211 and MAX8212 are CMOS micropower voltage detectors that warn microprocessors ( $\mu$ Ps) of power failures. Each contains a comparator, a 1.5V bandgap reference, and an open-drain N-channel output driver. Two external resistors are used in conjunction with the internal reference to set the trip voltage to the desired level. A hysteresis output is also included, allowing the user to apply positive feedback for noise-free output switching.

The MAX8211 provides a 7mA current-limited output sink whenever the voltage applied to the threshold pin is less than the 1.5V internal reference. In the MAX8212, a voltage greater than 1.5V at the threshold pin turns the output stage on (no current limit).

The CMOS MAX8211/MAX8212 are plug-in replacements for the bipolar ICL8211/ICL8212 in applications where the maximum supply voltage is less than 16.5V. They offer several performance advantages, including reduced supply current, a more tightly controlled bandgap reference, and more available current from the hysteresis output.

## Applications

- $\mu$ P Voltage Monitoring
- Undervoltage Detection
- Overvoltage Detection
- Battery-Backup Switching
- Power-Supply Fault Monitoring
- Low-Battery Detection

## Pin Configuration

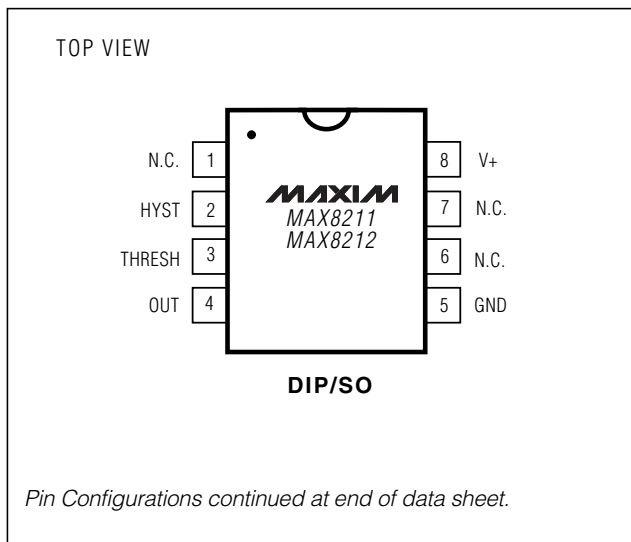

## Features

- ◆  $\mu$ P Power-Fail Warning
- ◆ Improved 2nd Source for ICL8211/ICL8212
- ◆ Low-Power CMOS Design
- ◆ 5 $\mu$ A Quiescent Current
- ◆ On-Board Hysteresis Output
- ◆  $\pm 40$ mV Threshold Accuracy ( $\pm 3.5\%$ )
- ◆ 2.0V to 16.5V Supply-Voltage Range
- ◆ Define Output Current Limit (MAX8211)
- ◆ High Output Current Capability (MAX8212)

## Ordering Information

PART	TEMP RANGE	PIN-PACKAGE
MAX8211CPA	0°C to +70°C	8 Plastic DIP
MAX8211CSA	0°C to +70°C	8 SO
MAX8211CUA	0°C to +70°C	8 $\mu$ MAX
MAX8211CTY	0°C to +70°C	8 TO-99
MAX8211EPA	-40°C to +85°C	8 Plastic DIP
MAX8211ESA	-40°C to +85°C	8 SO
MAX8211EJA	-40°C to +85°C	8 CERDIP
MAX8211ETY	-40°C to +85°C	8 TO-99
MAX8211MJA	-55°C to +125°C	8 CERDIP
MAX8211MTV	-55°C to +125°C	8 TO-99

Ordering Information continued on last page.  
\*Contact factory for dice specifications.

## Typical Operating Circuit

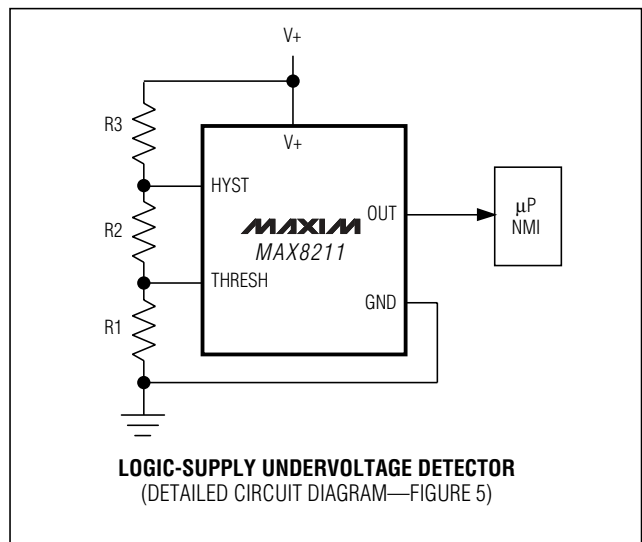

# Microprocessor Voltage Monitors with Programmable Voltage Detection

## ABSOLUTE MAXIMUM RATINGS

Supply Voltage .....	-0.5V to +18V	8-Pin CERDIP (derate 8.00mW/°C above +70°C).....	640mW
Output Voltage .....	-0.5V to +18V	8-Pin TO-99 (derate 6.67mW/°C above +70°C).....	533mW
Hysteresis.....	+0.5V to -18V with respect to (V+ + 0.5V)	Operating Temperature Ranges	
Threshold Input Voltage .....	-0.5V to (V+ + 0.5V)	MAX821_C_.....	0°C to +70°C
Current into Any Terminal.....	±50mA	MAX821_E_.....	-40°C to +85°C
Continuous Power Dissipation (T <sub>A</sub> = +70°C)		MAX821_M_.....	-55°C to +125°C
8-Pin Plastic DIP (derate 9.09mW/°C above +70°C) .....	727mW	Storage Temperature Range .....	-65°C to +150°C
8-Pin SO (derate 5.88mW/°C above +70°C).....	471mW	Lead Temperature (soldering, 10s) .....	+300°C

Stresses beyond those listed under "Absolute Maximum Ratings" may cause permanent damage to the device. These are stress ratings only, and functional operation of the device at these or any other conditions beyond those indicated in the operational sections of the specifications is not implied. Exposure to absolute maximum rating conditions for extended periods may affect device reliability.

## ELECTRICAL CHARACTERISTICS

(V+ = 5V, T<sub>A</sub> = +25°C, unless otherwise noted.)

PARAMETER	SYMBOL	CONDITIONS	MAX8211		MAX8212		UNITS
			MIN	TYP MAX	MIN	TYP MAX	
Supply Current	I <sub>+</sub>	2V ≤ V <sub>+</sub> ≤ 16.5V, GND ≤ V <sub>TH</sub> ≤ V <sub>+</sub>	T <sub>A</sub> = +25°C		5	15	μA
			T <sub>A</sub> = T <sub>MIN</sub> to T <sub>MAX</sub>		20		
Threshold Trip Voltage	V <sub>TH</sub>	T <sub>A</sub> = +25°C	V <sub>+</sub> = 16.5V, I <sub>OUT</sub> = 4mA		1.11	1.19	V
			V <sub>+</sub> = 2V, I <sub>OUT</sub> = 500μA		1.11		
		T <sub>A</sub> = T <sub>MIN</sub> to T <sub>MAX</sub>	V <sub>+</sub> = 16.5V, I <sub>OUT</sub> = 3mA		1.05	1.25	
			V <sub>+</sub> = 2.2V, I <sub>OUT</sub> = 500μA		1.05		
Threshold Voltage Disparity between Output and Hysteresis Output	V <sub>THP</sub>	I <sub>OUT</sub> = 4mA, I <sub>HYST</sub> = 1mA	±0.1		±0.1		mV
Guaranteed Operating Supply Voltage Range	V <sub>SUPP</sub>	T <sub>A</sub> = +25°C	2.0	16.5	2.0	16.5	V
		T <sub>A</sub> = T <sub>MIN</sub> to T <sub>MAX</sub>	2.2	16.5	2.2	16.5	
Typical Operating Supply Voltage Range	V <sub>SUPP</sub>		1.5	16.5	1.5	16.5	V
Threshold Voltage Temperature Coefficient	ΔV <sub>TH</sub> /ΔT	See Figure 4	-200		-200		ppm/°C
Variation of Threshold Voltage with Supply Voltage	ΔV <sub>TH</sub>	V <sub>+</sub> = 4.5V to 5.5V	1.0		0.2		mV
Threshold Input Current	I <sub>TH</sub>	0V ≤ V <sub>TH</sub> ≤ V <sub>+</sub> , T <sub>A</sub> = +25°C	0.01	10	0.01	10	nA
		T <sub>A</sub> = T <sub>MIN</sub> to T <sub>MAX</sub>	20		20		
Output Leakage Current	I <sub>LOUT</sub>	T <sub>A</sub> = T <sub>MIN</sub> to T <sub>MAX</sub> , C/E temp. ranges	V <sub>OUT</sub> = 16.5V, V <sub>TH</sub> = 1.0V				10
			V <sub>OUT</sub> = 16.5V, V <sub>TH</sub> = 1.3V		10		
			V <sub>OUT</sub> = 5V, V <sub>TH</sub> = 1.0V				1
			V <sub>OUT</sub> = 5V, V <sub>TH</sub> = 1.3V		1		
		T <sub>A</sub> = T <sub>MIN</sub> to T <sub>MAX</sub> , M temp. range	V <sub>OUT</sub> = 16.5V, V <sub>TH</sub> = 0.9V				30
			V <sub>OUT</sub> = 16.5V, V <sub>TH</sub> = 1.3V		30		
			V <sub>OUT</sub> = 5V, V <sub>TH</sub> = 0.9V				10
			V <sub>OUT</sub> = 5V, V <sub>TH</sub> = 1.3V		10		

# Microprocessor Voltage Monitors with Programmable Voltage Detection

MAX8211/MAX8212

## ELECTRICAL CHARACTERISTICS (continued)

(V+ = 5V, T<sub>A</sub> = +25°C, unless otherwise noted.)

PARAMETER	SYMBOL	CONDITIONS	MAX8211		MAX8212		UNITS
			MIN	TYP	MAX	MIN	
Output Saturation Voltage	V <sub>OL</sub>	I <sub>OUT</sub> = 2mA, V <sub>TH</sub> = 1.0V	0.17	0.4			V
		I <sub>OUT</sub> = 2mA, V <sub>TH</sub> = 1.3V			0.17	0.4	
Maximum Available Output Current	I <sub>OH</sub>	C temp. range, V <sub>OUT</sub> = 5V	V <sub>TH</sub> = 1.0V (Note 1)				mA
			V <sub>TH</sub> = 1.3V (Note 2)				
Hysteresis Leakage Current	I <sub>LHYS</sub>	T <sub>A</sub> = T <sub>MIN</sub> to T <sub>MAX</sub> , C/E temp. ranges, V+ = 16.5V, V <sub>TH</sub> = 1.0V, V <sub>HYST</sub> = -16.5V with respect to V+			0.1	0.1	μA
		T <sub>A</sub> = T <sub>MIN</sub> to T <sub>MAX</sub> , M temp. range, V+ = 16.5V, V <sub>TH</sub> = 0.9V, V <sub>HYST</sub> = -16.5V with respect to V+			3	3	
Hysteresis Saturation Voltage	V <sub>HYS</sub> (MAX)	I <sub>HYST</sub> = 0.5mA, V <sub>TH</sub> = 1.3V, measured with respect to V+	-0.1	-0.2	-0.1	-0.2	V
Maximum Available Hysteresis Current	V <sub>HYS</sub> (MAX)	V <sub>TH</sub> = 1.3V, V <sub>HYS</sub> = 0V	2	10	2	10	mA

**Note 1:** The maximum output current of the MAX8211 is limited by design to 30mA under any operating condition. The output voltage may be sustained at any voltage up to +16.5V as long as the maximum power dissipation of the device is not exceeded.

**Note 2:** The maximum output current of the MAX8212 is not defined, and systems using the MAX8212 must therefore ensure that the output current does not exceed 50mA and that the maximum power dissipation of the device is not exceeded.

## Detailed Description

As shown in the block diagrams of Figures 1 and 2, the MAX8211 and MAX8212 each contain a 1.15V reference, a comparator, an open-drain N-channel output transistor, and an open-drain P-channel hysteresis output. The MAX8211 output N-channel turns on when the voltage applied to the THRESH pin is less than the internal reference (1.15V). The sink current is limited to 7mA (typical), allowing direct drive of an LED without a series resistor. The MAX8212 output turns on when the voltage applied to THRESH is greater than the internal reference. It is not current limited, and will typically sink 35mA.

### Compatibility with ICL8211/ICL8212

The CMOS MAX8211/MAX8212 are plug-in replacements for the bipolar ICL8211/ICL8212 in most applications. The use of CMOS technology has several advantages. The quiescent supply current is much less than in the bipolar parts. Higher-value resistors can also be used

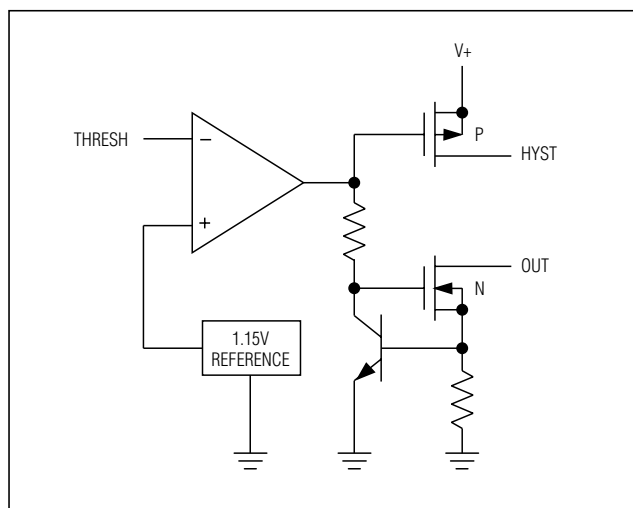

Figure 1. MAX8211 Block Diagram

# Microprocessor Voltage Monitors with Programmable Voltage Detection

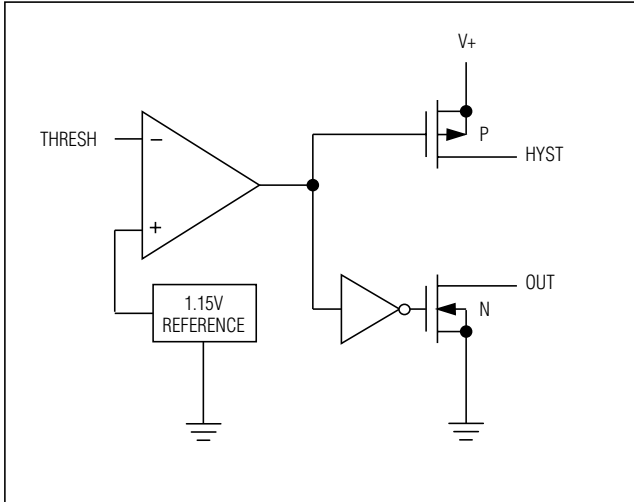

Figure 2. MAX8212 Block Diagram

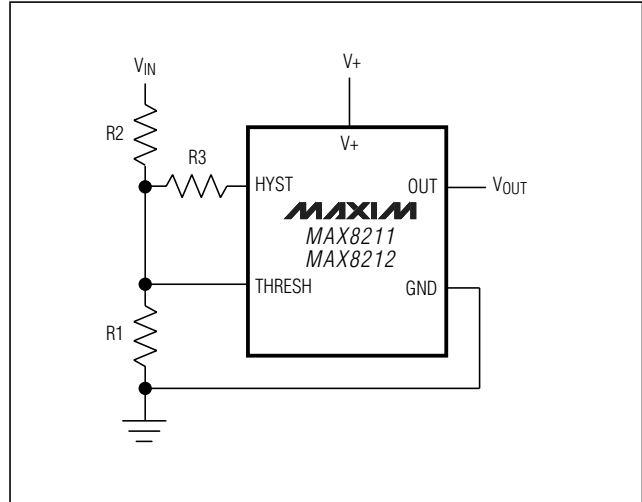

Figure 3. Basic Overvoltage/Undervoltage Circuit

in the networks that set up the trip voltage, since the comparator input (THRESH pin) is a low-leakage MOSFET transistor. This further reduces system current drain. The tolerance of the internal reference has also been significantly improved, allowing for more precise voltage detection without the use of potentiometers.

The available current from the HYST output has been increased from 21 $\mu$ A to 10mA, making the hysteresis feature easier to use. The disparity between the HYST output and the voltage required at THRESH to switch the OUT pin has also been reduced in the MAX8211 from 8mV to 0.1mV to eliminate output “chatter” or oscillation.

Most voltage detection circuits operate with supplies of 15V or less; in these applications, the MAX8211/MAX8212 will replace ICL8211/ICL8212s with the performance advantages described above. However, note that the CMOS parts have an absolute maximum supply-voltage rating of 18V, and should never be used in applications where this rating could be exceeded. Exercise caution when replacing ICL8211/ICL8212s in closed-loop applications such as programmable zeners. Although neither the ICL8211/ICL8212 nor the MAX8211/MAX8212 are internally compensated, the CMOS parts have higher gain and may not be stable for the external compensation-capacitor values used in lower-gain ICL8211/ICL8212 circuits.

## Applications Information

### Basic Voltage Detectors

Figure 3 shows the basic circuit for both undervoltage detection (MAX8211) and overvoltage detection (MAX8212). For applications where no hysteresis is needed, R3 should be omitted. The ratio of R1 to R2 is then chosen such that, for the desired trip voltage at  $V_{IN}$ , 1.15V is applied to the THRESH pin. Since the comparator inputs are very low-leakage MOSFET transistors, the MAX8211/MAX8212 can use much higher resistor values in the attenuator network than can the bipolar ICL8211/ICL8212. See Table 1 for switching delays.

Table 1. Switching Delays

TYPICAL DELAYS	MAX8211	MAX8212
$t_{(on)}$	40 $\mu$ s	250 $\mu$ s
$t_{(off)}$	1.5ms	3ms

### Voltage Detectors with Hysteresis

To ensure noise-free output switching, hysteresis is frequently used in voltage detectors. For both the MAX8211 and MAX8212 the HYST output is on for threshold voltages greater than 1.15V. R3 (Figure 3) controls the amount of current (positive feedback) supplied from the HYST output to the mid-point of the resistor divider, and hence the magnitude of the hysteresis, or dead-band.

# Microprocessor Voltage Monitors with Programmable Voltage Detection

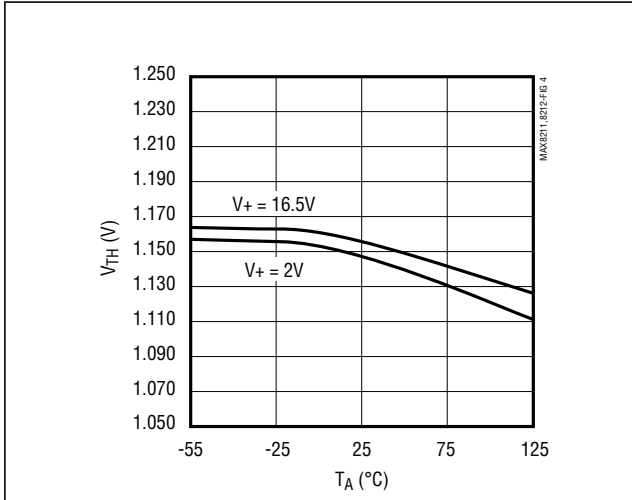

Figure 4. MAX8211/MAX8212 Threshold Trip Voltage vs. Ambient Temperature

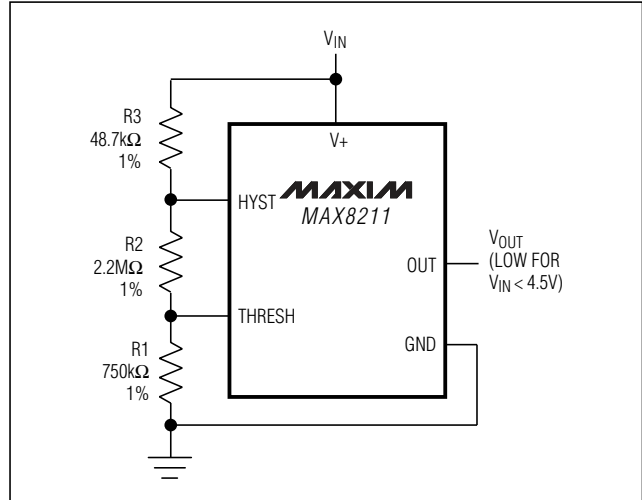

Figure 5. MAX8211 Logic-Supply Low-Voltage Detector

Calculate resistor values for Figure 3 as follows:

- 1) Choose a value for R1. Typical values are in the 10kΩ to 10MΩ range.
- 2) Calculate R2 for the desired upper trip point  $V_U$  using the formula:

$$R2 = R1 \times \frac{(V_U - V_{TH})}{V_{TH}} = R1 \times \frac{(V_U - 1.15V)}{1.15V}$$

- 3) Calculate R3 for the desired amount of hysteresis, where  $V_L$  is the lower trip point:

$$R3 = R2 \times \frac{(V_+ - V_{TH})}{(V_U - V_L)} = R2 \times \frac{(V_+ - 1.15V)}{(V_U - V_L)}$$

or, if  $V_+ = V_{IN}$ :

$$R3 = R2 \times \frac{(V_L - V_{TH})}{(V_U - V_L)} = R2 \times \frac{(V_L - 1.15V)}{(V_U - V_L)}$$

Figure 5 shows an alternate circuit, suitable only when the voltage being detected is also the power-supply voltage for the MAX8211 or MAX8212.

Calculate resistor values for Figure 5 as follows:

- 1) Choose a value for R1. Typical values are in the 10kΩ to 10MΩ range.
- 2) Calculate R2:

$$R2 = R1 \times \frac{(V_L - V_{TH})}{V_{TH}} = R1 \times \frac{(V_L - 1.15V)}{1.15V}$$

- 3) Calculate R3:

$$R3 = R1 \times \frac{(V_U - V_L)}{1.15V}$$

### Low-Voltage Detector for Logic Supply

The circuit of Figure 5 will detect when a 5.0V (nominal) supply goes below 4.5V, which is the  $V_{MIN}$  normally specified in logic systems. The selected resistor values ensure that false undervoltage alarms will not be generated, even with worst-case threshold trip values and resistor tolerances. R3 provides approximately 75mV of hysteresis.

# Microprocessor Voltage Monitors with Programmable Voltage Detection

## Pin Configurations (continued)

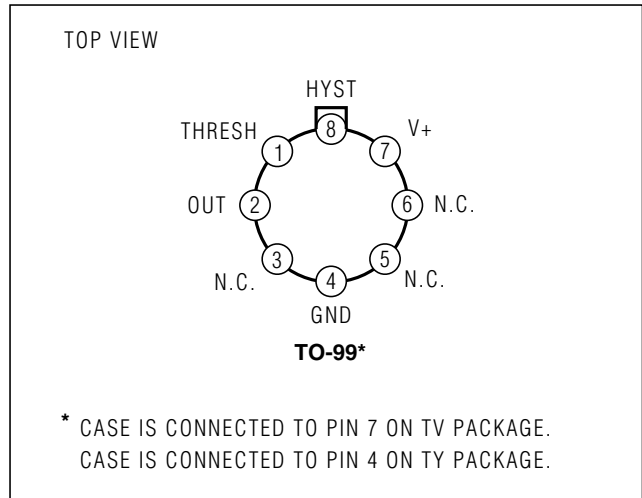
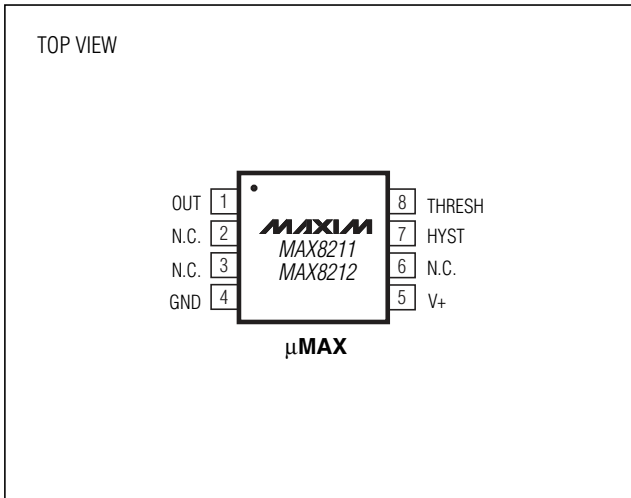

## Ordering Information (continued)

PART	TEMP RANGE	PIN-PACKAGE
MAX8212CPA	0°C to +70°C	8 Plastic DIP
MAX8212CSA	0°C to +70°C	8 SO
MAX8212CUA	0°C to +70°C	8 μMAX
MAX8212CTY	0°C to +70°C	8 TO-99
MAX8212EPA	-40°C to +85°C	8 Plastic DIP
MAX8212ESA	-40°C to +85°C	8 SO
MAX8212EJA	-40°C to +85°C	8 CERDIP
MAX8212ETY	-40°C to +85°C	8 TO-99
MAX8212MJA	-55°C to +125°C	8 CERDIP
MAX8212MTV	-55°C to +125°C	8 TO-99

\*Contact factory for dice specifications.

# Microprocessor Voltage Monitors with Programmable Voltage Detection

## Package Information

(The package drawing(s) in this data sheet may not reflect the most current specifications. For the latest package outline information, go to [www.maxim-ic.com/packages](http://www.maxim-ic.com/packages).)

MAX8211/MAX8212

8LUMAXD.EPS

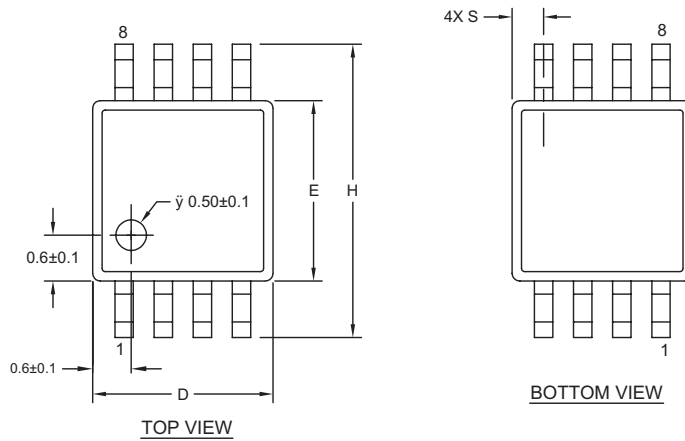

DIM	INCHES		MILLIMETERS	
	MIN	MAX	MIN	MAX
A	-	0.043	-	1.10
A1	0.002	0.006	0.05	0.15
A2	0.030	0.037	0.75	0.95
b	0.010	0.014	0.25	0.36
c	0.005	0.007	0.13	0.18
D	0.116	0.120	2.95	3.05
e	0.0256 BSC		0.65 BSC	
E	0.116	0.120	2.95	3.05
H	0.188	0.198	4.78	5.03
L	0.016	0.026	0.41	0.66
$\alpha$	0 $^\infty$	6 $^\infty$	0 $^\infty$	6 $^\infty$
S	0.0207 BSC		0.5250 BSC	

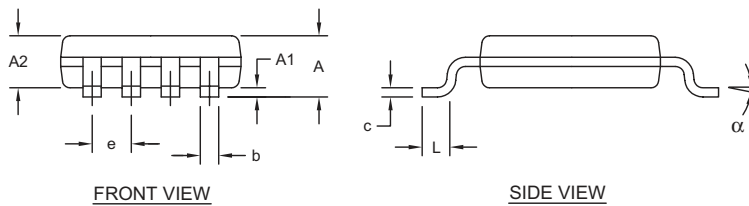

- NOTES:
1. D&E DO NOT INCLUDE MOLD FLASH.
  2. MOLD FLASH OR PROTRUSIONS NOT TO EXCEED 0.15MM (.006").
  3. CONTROLLING DIMENSION: MILLIMETERS.
  4. MEETS JEDEC MO-187C-AA.

**DALLAS SEMICONDUCTOR** **MAXIM**

PROPRIETARY INFORMATION

TITLE:  
PACKAGE OUTLINE, 8L uMAX/uSOP

APPROVAL	DOCUMENT CONTROL NO. 21-0036	REV. J	1/1
----------	---------------------------------	-----------	-----

# Microprocessor Voltage Monitors with Programmable Voltage Detection

## Package Information (continued)

(The package drawing(s) in this data sheet may not reflect the most current specifications. For the latest package outline information, go to [www.maxim-ic.com/packages](http://www.maxim-ic.com/packages).)

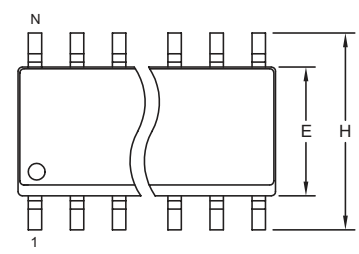

TOP VIEW

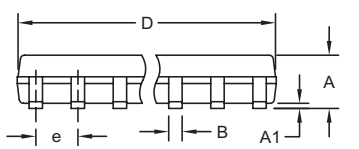

FRONT VIEW

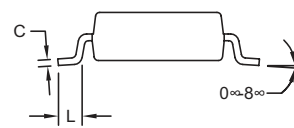

SIDE VIEW

DIM	INCHES		MILLIMETERS	
	MIN	MAX	MIN	MAX
A	0.053	0.069	1.35	1.75
A1	0.004	0.010	0.10	0.25
B	0.014	0.019	0.35	0.49
C	0.007	0.010	0.19	0.25
e	0.050 BSC		1.27 BSC	
E	0.150	0.157	3.80	4.00
H	0.228	0.244	5.80	6.20
L	0.016	0.050	0.40	1.27

VARIATIONS:

DIM	INCHES		MILLIMETERS		N	MS012
	MIN	MAX	MIN	MAX		
D	0.189	0.197	4.80	5.00	8	AA
D	0.337	0.344	8.55	8.75	14	AB
D	0.386	0.394	9.80	10.00	16	AC

NOTES:

1. D&E DO NOT INCLUDE MOLD FLASH.
2. MOLD FLASH OR PROTRUSIONS NOT TO EXCEED 0.15mm (.006").
3. LEADS TO BE COPLANAR WITHIN 0.10mm (.004").
4. CONTROLLING DIMENSION: MILLIMETERS.
5. MEETS JEDEC MS012.
6. N = NUMBER OF PINS.

<b>DALLAS SEMICONDUCTOR</b>		<b>MAXIM</b>	
<small>PROPRIETARY INFORMATION</small>			
TITLE: PACKAGE OUTLINE, .150" SOIC			
APPROVAL:	DOCUMENT CONTROL NO. 21-0041	REV. B	1/1

SOICN: EPS



# Microprocessor Voltage Monitors with Programmable Voltage Detection

## Package Information (continued)

(The package drawing(s) in this data sheet may not reflect the most current specifications. For the latest package outline information, go to [www.maxim-ic.com/packages](http://www.maxim-ic.com/packages).)

MAX8211/MAX8212

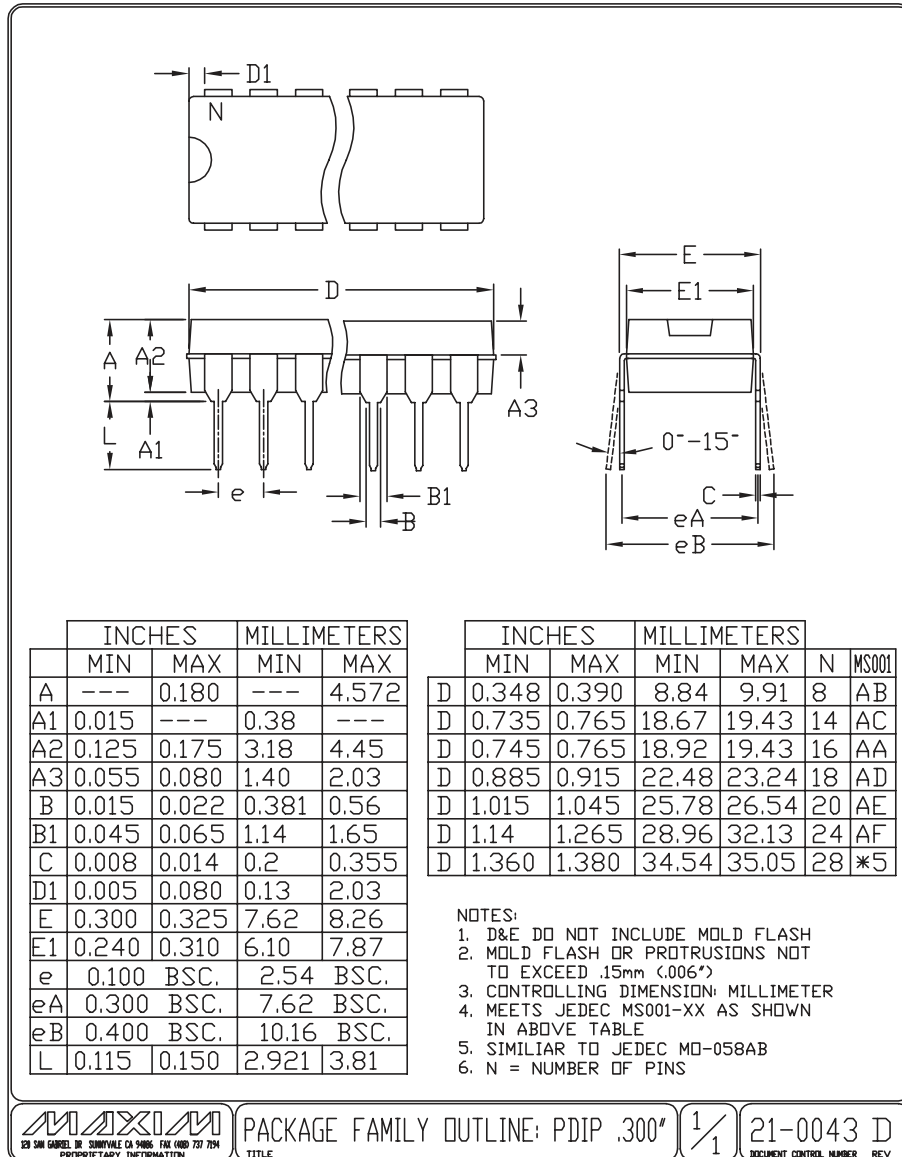

# Microprocessor Voltage Monitors with Programmable Voltage Detection

## Package Information (continued)

(The package drawing(s) in this data sheet may not reflect the most current specifications. For the latest package outline information, go to [www.maxim-ic.com/packages](http://www.maxim-ic.com/packages).)

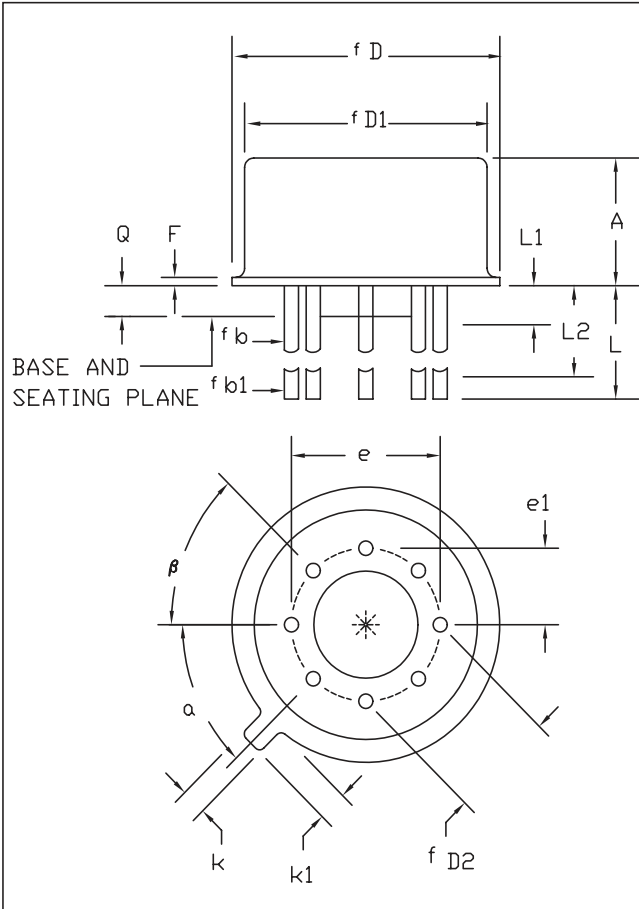

SYMBOL	INCHES		MILLIMETERS	
	MIN	MAX	MIN	MAX
A	.165	.185	4.19	4.70
f b	.016	.019	0.41	0.48
f b1	.016	.021	0.41	0.53
f b2	.016	.024	0.41	0.61
f D	.335	.375	8.51	9.40
f D1	.305	.335	7.75	8.51
f D2	.110	.160	2.79	4.06
e	.200 BSC		5.08 BSC	
e1	.100 BSC		2.54 BSC	
F	----	.040	----	1.02
k	.027	.034	0.69	0.86
k1	.027	.045	0.69	1.14
L	.500	.750	12.70	19.05
L1	----	.050	----	1.27
L2	.250	----	6.35	----
Q	.010	.045	0.25	1.14
$\alpha$	45° BSC		45° BSC	
$\beta$	45° BSC		45° BSC	

NOTES: DIMENSIONS ARE COMPLIANT TO MIL-STD-1835, A1.

TOLERANCES UNLESS OTHERWISE SPECIFIED		<b>MAXIM</b>
FRACTIONS	DEC ANGLES	
± N/A	±.001 ± N/A	PROPRIETARY INFORMATION
DRAWN BY:	DATE:	TITLE: CASE OUTLINE TO-99, 8LD
APPROVED BY:	DATE:	DOCUMENT CONTROL NO. REV. 21-0022 A

TO-99, 8LD, EPS

Maxim cannot assume responsibility for use of any circuitry other than circuitry entirely embodied in a Maxim product. No circuit patent licenses are implied. Maxim reserves the right to change the circuitry and specifications without notice at any time.

10 \_\_\_\_\_ **Maxim Integrated Products, 120 San Gabriel Drive, Sunnyvale, CA 94086 (408) 737-7600**

SITE  
SEARCHPART NO.  
SEARCH

WHAT'S NEW

PRODUCTS

SOLUTIONS

DESIGN

APPNOTES

SUPPORT

BUY

COMPANY

MEMBERS

[Maxim](#) > [Products](#) > [Timekeeping, Timers, and Counters](#)

# MAX8211, MAX8212

Microprocessor Voltage Monitors with Programmable Voltage Detection

[QuickView](#)[Technical Documents](#)[Ordering Info](#)[More Information](#)[All](#)

## Ordering Information

Notes:

- Other options and links for purchasing parts are listed at: <http://www.maxim-ic.com/sales>.
- [Didn't Find What You Need?](#) Ask our applications engineers. Expert assistance in finding parts, usually within one business day.
- Part number suffixes: T or T&R = tape and reel; + = RoHS/lead-free; # = RoHS/lead-exempt. More: See [Full Data Sheet](#) or [Part Naming Conventions](#).
- \* Some packages have variations, listed on the drawing. "PkgCode/Variation" tells which variation the product uses.

### Devices: 1-55 of 55

MAX8211	Free Sample	Buy	Package: TYPE PINS FOOTPRINT DRAWING CODE/VAR *	Temp	RoHS/Lead-Free? Materials Analysis
MAX8211EJA	<input type="checkbox"/>	<input type="checkbox"/>	Ceramic DIP;8 pin;81 mm Dwg: <a href="#">21-0045A</a> (PDF) Use pkgcode/variation: J8-2*	-40C to +85C	RoHS/Lead-Free: <a href="#">No Materials Analysis</a>
MAX8211MJA/HR	<input type="checkbox"/>	<input type="checkbox"/>	Ceramic DIP;8 pin;81 mm Dwg: <a href="#">21-0045A</a> (PDF) Use pkgcode/variation: J8-2*	-55C to +125C	RoHS/Lead-Free: <a href="#">No Materials Analysis</a>
MAX8211MJA/883B	<input type="checkbox"/>	<input type="checkbox"/>	Ceramic DIP;8 pin;81 mm Dwg: <a href="#">21-0045A</a> (PDF) Use pkgcode/variation: J8-2*	-55C to +125C	RoHS/Lead-Free: <a href="#">No Materials Analysis</a>
MAX8211MJA	<input type="checkbox"/>	<input type="checkbox"/>	Ceramic DIP;8 pin;81 mm Dwg: <a href="#">21-0045A</a> (PDF) Use pkgcode/variation: J8-2*	-55C to +125C	RoHS/Lead-Free: <a href="#">No Materials Analysis</a>
MAX8211C/D	<input type="checkbox"/>	<input type="checkbox"/>			RoHS/Lead-Free: See data sheet
MAX8211MFB/883B	<input type="checkbox"/>	<input type="checkbox"/>		-55C to +125C	RoHS/Lead-Free: See data sheet
MAX8211MTV/HR	<input type="checkbox"/>	<input type="checkbox"/>	Gold Can -TO;8 pin;88 mm Dwg: <a href="#">21-0022A</a> (PDF) Use pkgcode/variation: G99-8*	-55C to +125C	RoHS/Lead-Free: <a href="#">No Materials Analysis</a>
MAX8211MTV/883B	<input type="checkbox"/>	<input type="checkbox"/>	Gold Can -TO;8 pin;88 mm Dwg: <a href="#">21-0022A</a> (PDF) Use pkgcode/variation: G99-8*	-55C to +125C	RoHS/Lead-Free: <a href="#">No Materials Analysis</a>
MAX8211CTY	<input type="checkbox"/>	<input type="checkbox"/>	Metal Can-TO;8 pin;88 mm Dwg: <a href="#">21-0022A</a> (PDF) Use pkgcode/variation: T99-8*	0C to +70C	RoHS/Lead-Free: <a href="#">No Materials Analysis</a>
MAX8211CTY-2	<input type="checkbox"/>	<input type="checkbox"/>	Metal Can-TO;8 pin;88 mm Dwg: <a href="#">21-0022A</a> (PDF) Use pkgcode/variation: T99-8*	0C to +70C	RoHS/Lead-Free: <a href="#">No Materials Analysis</a>
MAX8211ETY	<input type="checkbox"/>	<input type="checkbox"/>	Metal Can-TO;8 pin;88 mm Dwg: <a href="#">21-0022A</a> (PDF) Use pkgcode/variation: T99-8*	-40C to +85C	RoHS/Lead-Free: <a href="#">No Materials Analysis</a>
MAX8211MTY	<input type="checkbox"/>	<input type="checkbox"/>	Metal Can-TO;8 pin;88 mm Dwg: <a href="#">21-0022A</a> (PDF) Use pkgcode/variation: T99-8*	-55C to +125C	RoHS/Lead-Free: <a href="#">No Materials Analysis</a>
MAX8211CPA+	<input type="checkbox"/>	<input type="checkbox"/>	PDIP;8 pin;82 mm Dwg: <a href="#">21-0043D</a> (PDF) Use pkgcode/variation: P8+1*	0C to +70C	RoHS/Lead-Free: <a href="#">Lead Free Materials Analysis</a>

MAX8211CPA			PDIP;8 pin;82 mm Dwg: <a href="#">21-0043D</a> (PDF) Use pkgcode/variation: P8-1*	0C to +70C	RoHS/Lead-Free: <a href="#">No Materials Analysis</a>
MAX8211EPA+			PDIP;8 pin;82 mm Dwg: <a href="#">21-0043D</a> (PDF) Use pkgcode/variation: P8+1*	-40C to +85C	RoHS/Lead-Free: <a href="#">Lead Free Materials Analysis</a>
MAX8211EPA			PDIP;8 pin;82 mm Dwg: <a href="#">21-0043D</a> (PDF) Use pkgcode/variation: P8-1*	-40C to +85C	RoHS/Lead-Free: <a href="#">No Materials Analysis</a>
MAX8211IPA			PDIP;8 pin;82 mm Dwg: <a href="#">21-0043D</a> (PDF) Use pkgcode/variation: P8-1*	-20C to +85C	RoHS/Lead-Free: <a href="#">No Materials Analysis</a>
MAX8211CSA+T			SOIC;8 pin;31 mm Dwg: <a href="#">21-0041B</a> (PDF) Use pkgcode/variation: S8+2*	0C to +70C	RoHS/Lead-Free: <a href="#">Lead Free Materials Analysis</a>
MAX8211CSA			SOIC;8 pin;31 mm Dwg: <a href="#">21-0041B</a> (PDF) Use pkgcode/variation: S8-2*	0C to +70C	RoHS/Lead-Free: <a href="#">No Materials Analysis</a>
MAX8211CSA-T			SOIC;8 pin;31 mm Dwg: <a href="#">21-0041B</a> (PDF) Use pkgcode/variation: S8-2*	0C to +70C	RoHS/Lead-Free: <a href="#">No Materials Analysis</a>
MAX8211CSA+			SOIC;8 pin;31 mm Dwg: <a href="#">21-0041B</a> (PDF) Use pkgcode/variation: S8+2*	0C to +70C	RoHS/Lead-Free: <a href="#">Lead Free Materials Analysis</a>
MAX8211ESA-T			SOIC;8 pin;31 mm Dwg: <a href="#">21-0041B</a> (PDF) Use pkgcode/variation: S8-2*	-40C to +85C	RoHS/Lead-Free: <a href="#">No Materials Analysis</a>
MAX8211ESA			SOIC;8 pin;31 mm Dwg: <a href="#">21-0041B</a> (PDF) Use pkgcode/variation: S8-2*	-40C to +85C	RoHS/Lead-Free: <a href="#">No Materials Analysis</a>
MAX8211ESA+			SOIC;8 pin;31 mm Dwg: <a href="#">21-0041B</a> (PDF) Use pkgcode/variation: S8+2*	-40C to +85C	RoHS/Lead-Free: <a href="#">Lead Free Materials Analysis</a>
MAX8211ESA+T			SOIC;8 pin;31 mm Dwg: <a href="#">21-0041B</a> (PDF) Use pkgcode/variation: S8+2*	-40C to +85C	RoHS/Lead-Free: <a href="#">Lead Free Materials Analysis</a>
MAX8211CUA+T			uMAX;8 pin;16 mm Dwg: <a href="#">21-0036J</a> (PDF) Use pkgcode/variation: U8+1*	0C to +70C	RoHS/Lead-Free: <a href="#">Lead Free Materials Analysis</a>
MAX8211CUA+			uMAX;8 pin;16 mm Dwg: <a href="#">21-0036J</a> (PDF) Use pkgcode/variation: U8+1*	0C to +70C	RoHS/Lead-Free: <a href="#">Lead Free Materials Analysis</a>
MAX8211CUA			uMAX;8 pin;16 mm Dwg: <a href="#">21-0036J</a> (PDF) Use pkgcode/variation: U8-1*	0C to +70C	RoHS/Lead-Free: <a href="#">No Materials Analysis</a>
MAX8211CUA-T			uMAX;8 pin;16 mm Dwg: <a href="#">21-0036J</a> (PDF) Use pkgcode/variation: U8-1*	0C to +70C	RoHS/Lead-Free: <a href="#">No Materials Analysis</a>
<b>MAX8212</b>	<b>Free Sample</b>	<b>Buy</b>	<b>Package: TYPE PINS FOOTPRINT DRAWING CODE/VAR *</b>	<b>Temp</b>	<b>RoHS/Lead-Free? Materials Analysis</b>
MAX8212EJA			Ceramic DIP;8 pin;81 mm Dwg: <a href="#">21-0045A</a> (PDF) Use pkgcode/variation: J8-2*	-40C to +85C	RoHS/Lead-Free: <a href="#">No Materials Analysis</a>
MAX8212MJA			Ceramic DIP;8 pin;81 mm Dwg: <a href="#">21-0045A</a> (PDF) Use pkgcode/variation: J8-2*	-55C to +125C	RoHS/Lead-Free: <a href="#">No Materials Analysis</a>
MAX8212MJA/883B			Ceramic DIP;8 pin;81 mm Dwg: <a href="#">21-0045A</a> (PDF) Use pkgcode/variation: J8-2*	-55C to +125C	RoHS/Lead-Free: <a href="#">No Materials Analysis</a>
MAX8212MTV/HR			Gold Can -TO;8 pin;88 mm Dwg: <a href="#">21-0022A</a> (PDF) Use pkgcode/variation: G99-8*	-55C to +125C	RoHS/Lead-Free: <a href="#">No Materials Analysis</a>
MAX8212MTV/883B			Gold Can -TO;8 pin;88 mm Dwg: <a href="#">21-0022A</a> (PDF) Use pkgcode/variation: G99-8*	-55C to +125C	RoHS/Lead-Free: <a href="#">No Materials Analysis</a>
MAX8212MTV			Gold Can -TO;8 pin;88 mm Dwg: <a href="#">21-0022A</a> (PDF) Use pkgcode/variation: G99-8*	-55C to +125C	RoHS/Lead-Free: <a href="#">No Materials Analysis</a>

MAX8212CTY			Metal Can-TO;8 pin;88 mm Dwg: <a href="#">21-0022A</a> (PDF) Use pkgcode/variation: T99-8*	0C to +70C	RoHS/Lead-Free: <a href="#">No Materials Analysis</a>
MAX8212CTY-2			Metal Can-TO;8 pin;88 mm Dwg: <a href="#">21-0022A</a> (PDF) Use pkgcode/variation: T99-8*	0C to +70C	RoHS/Lead-Free: <a href="#">No Materials Analysis</a>
MAX8212ETY			Metal Can-TO;8 pin;88 mm Dwg: <a href="#">21-0022A</a> (PDF) Use pkgcode/variation: T99-8*	-40C to +85C	RoHS/Lead-Free: <a href="#">No Materials Analysis</a>
MAX8212MTY			Metal Can-TO;8 pin;88 mm Dwg: <a href="#">21-0022A</a> (PDF) Use pkgcode/variation: T99-8*	-55C to +125C	RoHS/Lead-Free: <a href="#">No Materials Analysis</a>
MAX8212EPA+			PDIP;8 pin;82 mm Dwg: <a href="#">21-0043D</a> (PDF) Use pkgcode/variation: P8+1*	-40C to +85C	RoHS/Lead-Free: <a href="#">Lead Free Materials Analysis</a>
MAX8212CPA+			PDIP;8 pin;82 mm Dwg: <a href="#">21-0043D</a> (PDF) Use pkgcode/variation: P8+1*	0C to +70C	RoHS/Lead-Free: <a href="#">Lead Free Materials Analysis</a>
MAX8212CPA			PDIP;8 pin;82 mm Dwg: <a href="#">21-0043D</a> (PDF) Use pkgcode/variation: P8-1*	0C to +70C	RoHS/Lead-Free: <a href="#">No Materials Analysis</a>
MAX8212EPA			PDIP;8 pin;82 mm Dwg: <a href="#">21-0043D</a> (PDF) Use pkgcode/variation: P8-1*	-40C to +85C	RoHS/Lead-Free: <a href="#">No Materials Analysis</a>
MAX8212CSA+			SOIC;8 pin;31 mm Dwg: <a href="#">21-0041B</a> (PDF) Use pkgcode/variation: S8+2*	0C to +70C	RoHS/Lead-Free: <a href="#">Lead Free Materials Analysis</a>
MAX8212CSA			SOIC;8 pin;31 mm Dwg: <a href="#">21-0041B</a> (PDF) Use pkgcode/variation: S8-2*	0C to +70C	RoHS/Lead-Free: <a href="#">No Materials Analysis</a>
MAX8212CSA-T			SOIC;8 pin;31 mm Dwg: <a href="#">21-0041B</a> (PDF) Use pkgcode/variation: S8-2*	0C to +70C	RoHS/Lead-Free: <a href="#">No Materials Analysis</a>
MAX8212CSA+T			SOIC;8 pin;31 mm Dwg: <a href="#">21-0041B</a> (PDF) Use pkgcode/variation: S8+2*	0C to +70C	RoHS/Lead-Free: <a href="#">Lead Free Materials Analysis</a>
MAX8212ESA+			SOIC;8 pin;31 mm Dwg: <a href="#">21-0041B</a> (PDF) Use pkgcode/variation: S8+2*	-40C to +85C	RoHS/Lead-Free: <a href="#">Lead Free Materials Analysis</a>
MAX8212ESA+T			SOIC;8 pin;31 mm Dwg: <a href="#">21-0041B</a> (PDF) Use pkgcode/variation: S8+2*	-40C to +85C	RoHS/Lead-Free: <a href="#">Lead Free Materials Analysis</a>
MAX8212ESA			SOIC;8 pin;31 mm Dwg: <a href="#">21-0041B</a> (PDF) Use pkgcode/variation: S8-2*	-40C to +85C	RoHS/Lead-Free: <a href="#">No Materials Analysis</a>
MAX8212ESA-T			SOIC;8 pin;31 mm Dwg: <a href="#">21-0041B</a> (PDF) Use pkgcode/variation: S8-2*	-40C to +85C	RoHS/Lead-Free: <a href="#">No Materials Analysis</a>
MAX8212CUA+T			uMAX;8 pin;16 mm Dwg: <a href="#">21-0036J</a> (PDF) Use pkgcode/variation: U8+1*	0C to +70C	RoHS/Lead-Free: <a href="#">Lead Free Materials Analysis</a>
MAX8212CUA+			uMAX;8 pin;16 mm Dwg: <a href="#">21-0036J</a> (PDF) Use pkgcode/variation: U8+1*	0C to +70C	RoHS/Lead-Free: <a href="#">Lead Free Materials Analysis</a>
MAX8212CUA			uMAX;8 pin;16 mm Dwg: <a href="#">21-0036J</a> (PDF) Use pkgcode/variation: U8-1*	0C to +70C	RoHS/Lead-Free: <a href="#">No Materials Analysis</a>
MAX8212CUA-T			uMAX;8 pin;16 mm Dwg: <a href="#">21-0036J</a> (PDF) Use pkgcode/variation: U8-1*	0C to +70C	RoHS/Lead-Free: <a href="#">No Materials Analysis</a>

#### Didn't Find What You Need?

- [Next Day Product Selection Assistance from Applications Engineers](#)
- [Parametric Search](#)
- [Applications Help](#)

### QuickView

[Description](#)  
[Key Features](#)  
[Applications/Uses](#)  
[Key Specifications](#)  
[Diagram](#)

### Technical Documents

[Data Sheet](#)  
[Application Notes](#)  
[Design Guides](#)  
[Engineering Journals](#)  
[Reliability Reports](#)  
[Software/Models](#)  
[Evaluation Kits](#)

### Ordering Info

[Price and Availability](#)  
[Samples](#)  
[Buy Online](#)  
[Package Information](#)  
[Lead-Free Information](#)

### More Information

[Related Products](#)  
[Notes and Comments](#)  
[Evaluation Kits](#)

Document Ref.: 19-0539; Rev 4; 2003-09-12  
This page last modified: 2007-05-30

[CONTACT US: SEND US AN EMAIL](#)