

- **HIGH-DENSITY PROGRAMMABLE LOGIC**
 - 192 I/O Pins
 - 9000 PLD Gates
 - 384 Registers
 - High Speed Global Interconnect
 - Wide Input Gating for Fast Counters, State Machines, Address Decoders, etc.
 - Small Logic Block Size for Random Logic
- **HIGH PERFORMANCE E²CMOS[®] TECHNOLOGY**
 - $f_{max} = 100$ MHz Maximum Operating Frequency
 - $t_{pd} = 10$ ns Propagation Delay
 - TTL Compatible Inputs and Outputs
 - Electrically Erasable and Reprogrammable
 - Non-Volatile
 - 100% Tested at Time of Manufacture
 - Unused Product Term Shutdown Saves Power
- **IN-SYSTEM PROGRAMMABLE**
 - Supports ISP[™] or ispJTAG[™] Programming
 - Increased Manufacturing Yields, Reduced Time-to-Market, and Improved Product Quality
 - Reprogram Soldered Devices for Faster Debugging
- **100% IEEE 1149.1 BOUNDARY SCAN COMPATIBLE**
- **OFFERS THE EASE OF USE AND FAST SYSTEM SPEED OF PLDs WITH THE DENSITY AND FLEXIBILITY OF FIELD PROGRAMMABLE GATE ARRAYS**
 - Complete Programmable Device Can Combine Glue Logic and Structured Designs
 - Five Dedicated Clock Input Pins
 - Synchronous and Asynchronous Clocks
 - Programmable Output Slew Rate Control to Minimize Switching Noise
 - Flexible Pin Placement
 - Optimized Global Routing Pool Provides Global Interconnectivity
- **ispDesignEXPERT[™] – LOGIC COMPILER AND COMPLETE ISP DEVICE DESIGN SYSTEMS FROM HDL SYNTHESIS THROUGH IN-SYSTEM PROGRAMMING**
 - Superior Quality of Results
 - Tightly Integrated with Leading CAE Vendor Tools
 - Productivity Enhancing Timing Analyzer, Explore Tools, Timing Simulator and ispANALYZER[™]
 - PC and UNIX Platforms

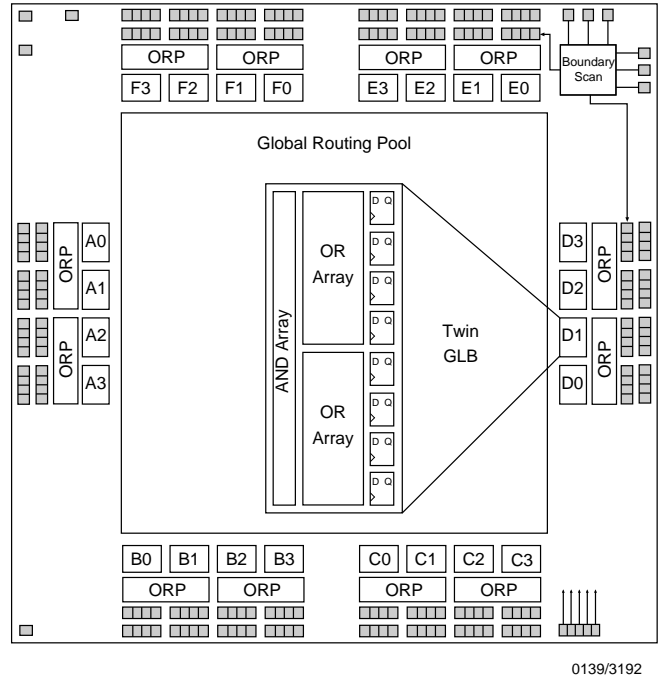

The ispLSI 3192 is a High Density Programmable Logic Device containing 384 Registers, 192 Universal I/O pins, five Dedicated Clock Input Pins, twelve Output Routing Pools (ORP), and a Global Routing Pool (GRP) which allows complete inter-connectivity between all of these elements. The ispLSI 3192 features 5-Volt in-system programmability and in-system diagnostic capabilities. The ispLSI 3192 offers non-volatile reprogrammability of the logic, as well as the interconnect to provide truly reconfigurable systems.

The basic unit of logic on the ispLSI 3192 device is the Twin Generic Logic Block (Twin GLB) labelled A0, A1...F3. There are a total of 24 of these Twin GLBs in the ispLSI 3192 device. Each Twin GLB has 24 inputs, a programmable AND array and two OR/Exclusive-OR Arrays, and eight outputs which can be configured to be either combinatorial or registered. All Twin GLB inputs come from the GRP.

Discontinued Product (PCN #06-07). Contact Rochester Electronics for Availability.
www.latticesemi.com/sales/discontinueddevicesales.cfm

Copyright © 2002 Lattice Semiconductor Corp. All brand or product names are trademarks or registered trademarks of their respective holders. The specifications and information herein are subject to change without notice.

Figure 1. ispLSI 3192 Functional Block Diagram

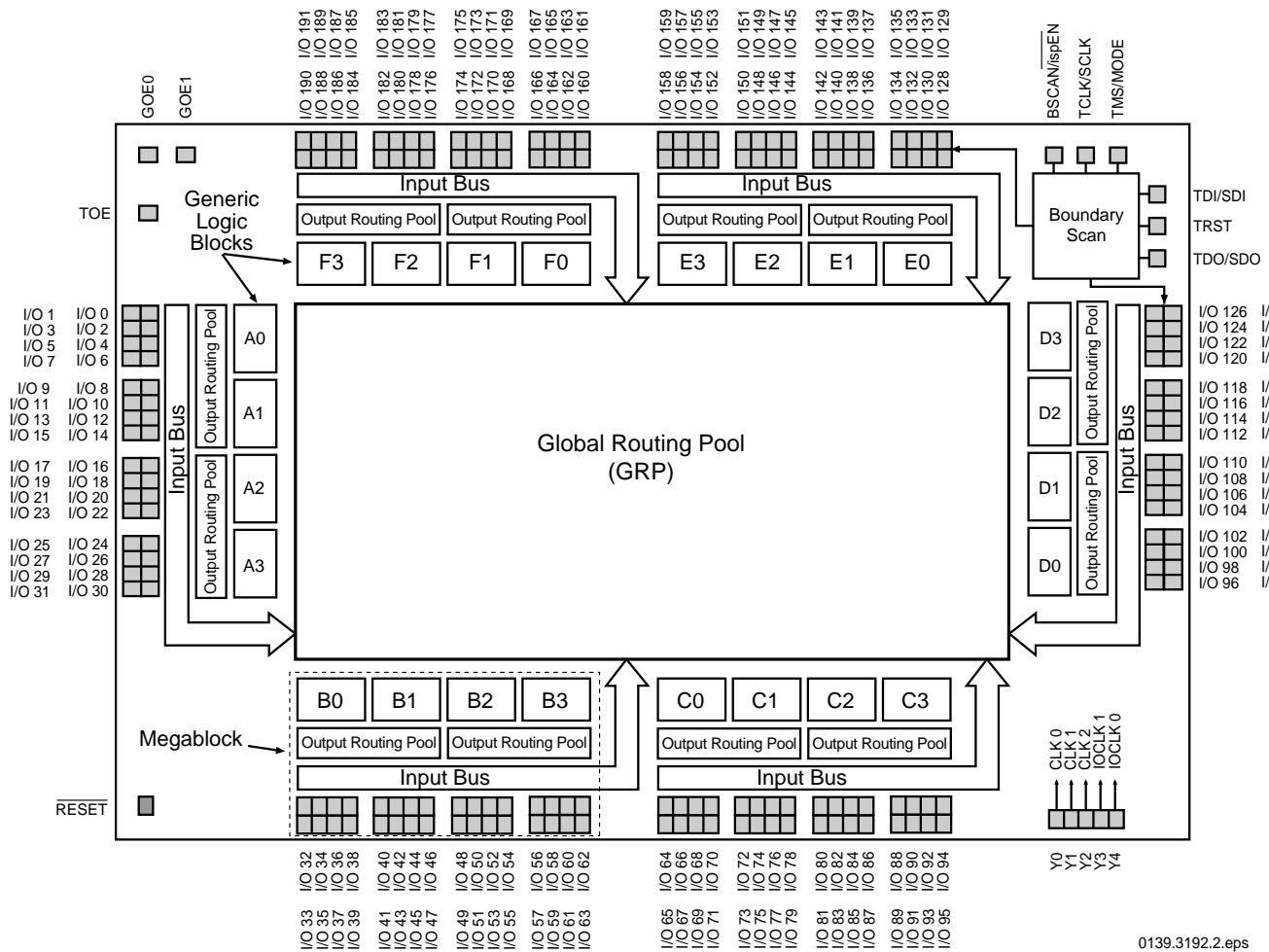

0139.3192.2.eps

Discontinued Product (PCN #06-07). Contact Rochester Electronics for Availability.
www.latticesemi.com/sales/discontinueddevicesales.cfm

All local logic block outputs are brought back into the GRP so they can be connected to the inputs of any other logic block on the device. The device also has 192 I/O cells, each of which is directly connected to an I/O pin. Each I/O cell can be individually programmed to be a combinatorial input, a registered input, a latched input, an output or a bidirectional I/O pin with 3-state control. The signal levels are TTL compatible voltages and the output drivers can source 4 mA or sink 8 mA. Each output can be programmed independently for fast or slow output slew rate to minimize overall output switching noise.

The 192 I/O Cells are grouped into six sets of 32 bits. Each of these I/O groups is associated with a logic Megablock through the use of the ORP. Each Megablock is able to provide one Product Term Output Enable (PTOE) signal which is globally distributed to all I/O cells. That PTOE signal can be generated within any GLB in the Megablock. Each I/O cell can select either a Global OE or a PTOE.

Four Twin GLBs, 32 I/O Cells and two ORPs are connected together to make a logic Megablock. The Megablock is defined by the resources that it shares. The outputs of the four Twin GLBs are connected to a set of 32 I/O cells by the two ORPs. The ispLSI 3192 device contains six of these Megablocks.

The GRP has as its inputs the outputs from all of the Twin GLBs and all of the inputs from the bidirectional I/O cells. All of these signals are made available to the inputs of the Twin GLBs. Delays through the GRP have been equalized to minimize timing skew and logic glitching.

Clocks in the ispLSI 3192 device are provided through five dedicated clock pins. The five pins provide three clocks to the Twin GLBs and two clocks to the I/O cells.

The table below lists key attributes of the device along with the number of resources available.

An additional feature of the ispLSI 3192 is the Boundary Scan capability, which is composed of cells connected between the on-chip system logic and the device's input and output pins. All I/O pins have associated boundary scan registers, with 3-state I/O using three boundary scan registers and inputs using one.

The ispLSI 3192 supports all IEEE 1149.1 mandatory instructions, which include BYPASS, EXTEST and SAMPLE.

Attribute	Quantity
Twin GLBs	24
Registers	384
I/O Pins	192
Global Clocks	5
Global OE	2
Test OE	1

Table - 003/3192

Discontinued Product (PCN #06-07). Contact Rochester Electronics for Availability.
www.latticesemi.com/sales/discontinueddevicesales.cfm

Supply Voltage V_{CC} -0.5 to +7.0V
 Input Voltage Applied -2.5 to $V_{CC} + 1.0V$
 Off-State Output Voltage Applied -2.5 to $V_{CC} + 1.0V$
 Storage Temperature -65 to 150°C
 Case Temp. with Power Applied -55 to 125°C
 Max. Junction Temp. (T_J) with Power Applied ... 150°C

1. Stresses above those listed under the “Absolute Maximum Ratings” may cause permanent damage to the device. Functional operation of the device at these or at any other conditions above those indicated in the operational sections of this specification is not implied (while programming, follow the programming specifications).

SYMBOL	PARAMETER	MIN.	MAX.	UNITS	
V_{CC}	Supply Voltage	Commercial $T_A = 0^\circ C$ to $+70^\circ C$	4.75	5.25	V
		Industrial $T_A = -40^\circ C$ to $+85^\circ C$	4.5	5.5	V
V_{IL}	Input Low Voltage	0	0.8	V	
V_{IH}	Input High Voltage	2.0	$V_{CC} + 1$	V	

Table 2 - 0005/3192

SYMBOL	PARAMETER	TYPICAL	UNITS	TEST CONDITIONS
C_1	I/O Capacitance	10	pf	$V_{CC} = 5.0V, V_{I/O} = 2.0V$
C_2	Clock Capacitance	15	pf	$V_{CC} = 5.0V, V_Y = 2.0V$

Table 2 - 0006/3192

PARAMETER	MINIMUM	MAXIMUM	UNITS
Data Retention	20	–	Years
ispLSI Erase/Reprogram Cycles	10000	–	Cycles

Table 2 - 0008B

Discontinued Product (PCN #06-07). Contact Rochester Electronics for Availability.
www.latticesemi.com/sales/discontinueddevicesales.cfm

Input Pulse Levels	GND to 3.0V
Input Rise and Fall Time	≤ 3ns 10% to 90%
Input Timing Reference Levels	1.5V
Output Timing Reference Levels	1.5V
Output Load	See figure 2

3-state levels are measured 0.5V from steady-state active level. Table 2 - 0003

Output Load conditions (See figure 2)

TEST CONDITION		R1	R2	CL
A		470Ω	390Ω	35pF
B	Active High	∞	390Ω	35pF
	Active Low	470Ω	390Ω	35pF
C	Active High to Z at $V_{OH}-0.5V$	∞	390Ω	5pF
	Active Low to Z at $V_{OL}+0.5V$	470Ω	390Ω	5pF

Table 2 - 0004A

Figure 2. Test Load

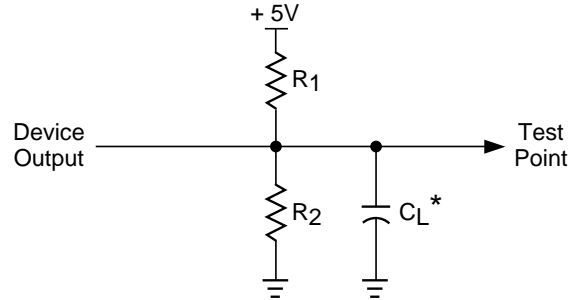

* C_L includes Test Fixture and Probe Capacitance.

0213A

Over Recommended Operating Conditions

SYMBOL	PARAMETER	CONDITION	MIN.	TYP. ³	MAX.	UNITS	
V_{OL}	Output Low Voltage	$I_{OL} = 8 \text{ mA}$	-	-	0.4	V	
V_{OH}	Output High Voltage	$I_{OH} = -4 \text{ mA}$	2.4	-	-	V	
I_{IL}	Input or I/O Low Leakage Current	$0V \leq V_{IN} \leq V_{IL} (\text{Max.})$	-	-	-10	μA	
I_{IH}	Input or I/O High Leakage Current	$3.5V \leq V_{IN} \leq V_{CC}$	-	-	10	μA	
I_{IL-isp}	Bscan/ $\overline{\text{ispEN}}$ Input Low Leakage Current	$0V \leq V_{IN} \leq V_{IL}$	-	-	-150	μA	
I_{IL-PU}	I/O Active Pull-Up Current	$0V \leq V_{IN} \leq V_{IL}$	-	-	-150	μA	
I_{OS}^1	Output Short Circuit Current	$V_{CC} = 5V, V_{OUT} = 0.5V$	-	-	-200	mA	
$I_{CC}^{2,4}$	Operating Power Supply Current	$V_{IL} = 0.0V, V_{IH} = 3.0V$ $f_{TOGGLE} = 1 \text{ MHz}$	Commercial	-	320	-	mA
			Industrial	-	320	-	mA

Table 2 - 0007isp/3192

- One output at a time for a maximum duration of one second. $V_{OUT} = 0.5V$ was selected to avoid test problems by tester ground degradation. Characterized but not 100% tested.
- Measured using twelve 16-bit counters.
- Typical values are at $V_{CC} = 5V$ and $T_A = 25^\circ C$.
- Maximum I_{CC} varies widely with specific device configuration and operating frequency. Refer to the Power Consumption section of this datasheet and Thermal Management section of the Lattice Semiconductor Data Book or CD-ROM to estimate maximum I_{CC} .

Discontinued Product (PCN #06-07). Contact Rochester Electronics for Availability.
www.latticesemi.com/sales/discontinueddevicessales.cfm

Over Recommended Operating Conditions

PARAMETER	TEST ⁵ COND.	# ²	DESCRIPTION ¹	-100		-70		UNITS
				MIN.	MAX.	MIN.	MAX.	
t _{pd1}	A	1	Data Prop. Delay, 4PT Bypass, ORP Bypass	—	10	—	15	ns
t _{pd2}	A	2	Data Propagation Delay	—	13	—	18	ns
f _{max}	A	3	Clock Frequency with Internal Feedback ³	100	—	70	—	MHz
f _{max} (Ext.)	—	4	Clock Freq. with Ext. Feedback, 1/(t _{su2} + t _{co1})	80	—	50	—	MHz
f _{max} (Tog.)	—	5	Clock Frequency, Max Toggle ⁴	125	—	83	—	MHz
t _{su1}	—	6	GLB Reg. Setup Time before Clock, 4PT bypass	5.5	—	9	—	ns
t _{co1}	A	7	GLB Reg. Clock to Output Delay, ORP bypass	—	6	—	9	ns
t _{h1}	—	8	GLB Reg. Hold Time after Clock, 4PT bypass	0	—	0	—	ns
t _{su2}	—	9	GLB Reg. Setup Time before Clock	6.5	—	11	—	ns
t _{co2}	—	10	GLB Reg. Clock to Output Delay	—	6.5	—	10	ns
t _{h2}	—	11	GLB Reg. Hold Time after Clock	0	—	0	—	ns
t _{r1}	A	12	Ext. Reset Pin to Output Delay	—	13.5	—	15	ns
t _{rw1}	—	13	Ext. Reset Pulse Duration	6.5	—	12	—	ns
t _{p_{to}een}	B	14	Input to Output Enable	—	15	—	18	ns
t _{p_{to}edis}	C	15	Input to Output Disable	—	15	—	18	ns
t _{goeen}	B	16	Global OE Output Enable	—	9	—	12	ns
t _{goedis}	C	17	Global OE Output Disable	—	9	—	12	ns
t _{toeen}	—	18	Test OE Output Enable	—	12	—	15	ns
t _{toedis}	—	19	Test OE Output Disable	—	12	—	15	ns
t _{wh}	—	20	Ext. Sync. Clock Pulse Duration, High	4	—	6	—	ns
t _{wl}	—	21	Ext. Sync. Clock Pulse Duration, Low	4	—	6	—	ns
t _{su3}	—	22	I/O Reg. Setup Time before Ext. Sync. Clock (Y3, Y4)	3.5	—	5	—	ns
t _{h3}	—	23	I/O Reg. Hold Time after Ext. Sync. Clock (Y3, Y4)	0	—	0	—	ns

1. Unless noted otherwise, all parameters use 20 PTXOR path and ORP.
2. Refer to Timing Model in this data sheet for further details.
3. Standard 16-bit counter using GRP feedback.
4. f_{max} (Toggle) may be less than 1/(t_{wh} + t_{wl}). This is to allow for a clock duty cycle of other than 50%.
5. Reference Switching Test Conditions section.

Timing Ext.6192.eps

Discontinued Product (PCN #06-07). Contact Rochester Electronics for Availability. www.latticesemi.com/sales/discontinueddevicesales.cfm

Over Recommended Operating Conditions

PARAMETER	# ²	DESCRIPTION	-100		-70		UNITS
			MIN.	MAX.	MIN.	MAX.	
Inputs							
t _{iobp}	24	I/O Register Bypass	—	1.3	—	1.9	ns
t _{iolat}	25	I/O Latch Delay	—	9.2	—	11.9	ns
t _{iosu}	26	I/O Register Setup Time before Clock	6.5	—	9.3	—	ns
t _{ioh}	27	I/O Register Hold Time after Clock	-3.0	—	-4.3	—	ns
t _{ioco}	28	I/O Register Clock to Out Delay	—	3.3	—	5.9	ns
t _{ior}	29	I/O Register Reset to Out Delay	—	3.3	—	3.9	ns
GRP							
t _{grp}	30	GRP Delay	—	1.4	—	2.1	ns
GLB							
t _{4ptbp}	31	4 Product Term Bypass Path Delay (Comb.)	—	4.3	—	7.8	ns
t _{4ptbr}	32	4 Product Term Bypass Path Delay (Reg.)	—	5.5	—	7.4	ns
t _{1ptxor}	33	1 Product Term/XOR Path Delay	—	6.0	—	8.3	ns
t _{20ptxor}	34	20 Product Term/XOR Path Delay	—	6.5	—	9.4	ns
t _{xoradj}	35	XOR Adjacent Path Delay ³	—	7.1	—	10.3	ns
t _{gbp}	36	GLB Register Bypass Delay	—	0.3	—	0.4	ns
t _{gsu}	37	GLB Register Setup Time before Clock	0.2	—	1.7	—	ns
t _{gh}	38	GLB Register Hold Time after Clock	3.5	—	5.3	—	ns
t _{gco}	39	GLB Register Clock to Output Delay	—	0.1	—	1.7	ns
t _{gro}	40	GLB Register Reset to Output Delay	—	2.4	—	2.8	ns
t _{ptre}	41	GLB Product Term Reset to Register Delay	—	5.0	—	7.5	ns
t _{ptoe}	42	GLB Product Term Output Enable to I/O Cell Delay	—	7.6	—	9.2	ns
t _{ptck}	43	GLB Product Term Clock Delay	4.9	5.9	7.4	8.8	ns
ORP							
t _{orp}	44	ORP Delay	—	1.1	—	1.7	ns
t _{orpbp}	45	ORP Bypass Delay	—	0.6	—	0.7	ns

1. Internal Timing Parameters are not tested and are for reference only.
2. Refer to Timing Model in this data sheet for further details.
3. The XOR adjacent path can only be used by hard macros.

Discontinued Product (PCN #06-07). Contact Rochester Electronics for Availability. www.latticesemi.com/sales/discontinueddevicesales.cfm

Over Recommended Operating Conditions

PARAMETER	# ²	DESCRIPTION	-100		-70		UNITS
			MIN.	MAX.	MIN.	MAX.	
Outputs							
tob	46	Output Buffer Delay	—	2.4	—	2.5	ns
tobs	47	Output Buffer Delay, Slow Slew	—	22.4	—	27.5	ns
toen	48	I/O Cell OE to Output Enabled	—	4.7	—	4.8	ns
todis	49	I/O Cell OE to Output Disabled	—	4.7	—	4.8	ns
Clocks							
tgy0/1/2	50	Clock Delay, Y0 or Y1 or Y2 to Global GLB Clk Line	2.9	2.9	4.1	4.1	ns
tioy3/4	51	Clock Delay, Y3 or Y4 to I/O Cell Global Clock Line	3.0	3.0	4.3	4.3	ns
Global Reset							
tgr	52	Global Reset to GLB and I/O Registers	—	7.6	—	8.0	ns
tgoe	53	Global OE Pad Buffer	—	4.3	—	7.2	ns
ttoe	54	Test OE Pad Buffer	—	7.3	—	10.2	ns

1. Internal Timing Parameters are not tested and are for reference only.
2. Refer to Timing Model in this data sheet for further details.

Timing Int.2.3192.eps

Discontinued Product (PCN #06-07). Contact Rochester Electronics for Availability.
www.latticesemi.com/sales/discontinueddevicesales.cfm

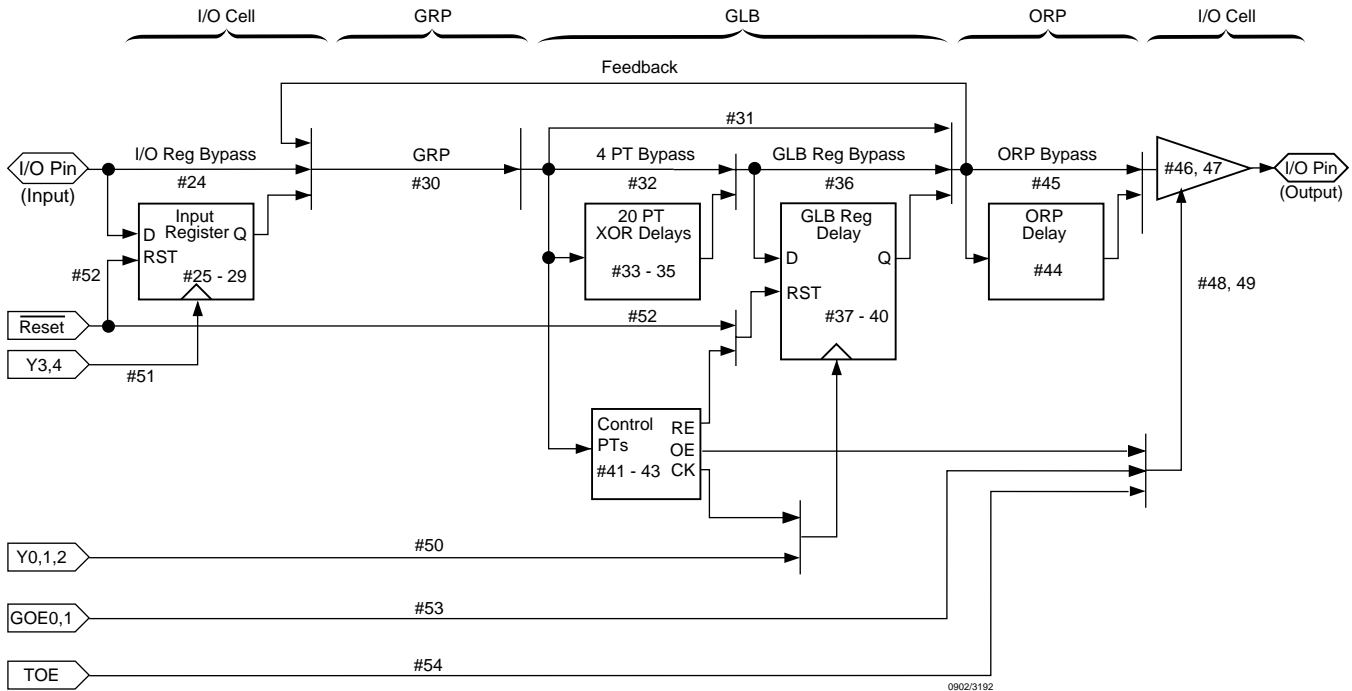

Derivations of t_{su} , t_h and t_{co} from the Product Term Clock¹

$$\begin{aligned}
 t_{su} &= \text{Logic} + \text{Reg } s_u - \text{Clock (min)} \\
 &= (t_{iobp} + t_{grp} + t_{20ptxor}) + (t_{gsu}) - (t_{iobp} + t_{grp} + t_{ptck(min)}) \\
 &= (\#24 + \#30 + \#34) + (\#37) - (\#24 + \#30 + \#43) \\
 1.8 \text{ ns} &= (1.3 + 1.4 + 6.5) + (0.2) - (1.3 + 1.4 + 4.9) \\
 \\
 t_h &= \text{Clock (max)} + \text{Reg } h - \text{Logic} \\
 &= (t_{iobp} + t_{grp} + t_{ptck(max)}) + (t_{gh}) - (t_{iobp} + t_{grp} + t_{20ptxor}) \\
 &= (\#24 + \#30 + \#43) + (\#38) - (\#24 + \#30 + \#34) \\
 2.9 \text{ ns} &= (1.3 + 1.4 + 5.9) + (3.5) - (1.3 + 1.4 + 6.5) \\
 \\
 t_{co} &= \text{Clock (max)} + \text{Reg } c_o + \text{Output} \\
 &= (t_{iobp} + t_{grp} + t_{ptck(max)}) + (t_{gco}) + (t_{orp} + t_{ob}) \\
 &= (\#24 + \#30 + \#43) + (\#39) + (\#44 + \#46) \\
 12.2 \text{ ns} &= (1.3 + 1.4 + 5.9) + (0.1) + (1.1 + 2.4)
 \end{aligned}$$

Table 2- 0042-3192

Note: Calculations are based upon timing specifications for the ispLSI 3192-100L.

Discontinued Product (PCN #06-07). Contact Rochester Electronics for Availability. www.latticesemi.com/sales/discontinueddevicesales.cfm

Power Consumption in the ispLSI 3192 device depends on two primary factors: the speed at which the device is

operating and the number of product terms used. Figure 3 shows the relationship between power and operating speed.

Figure 3. Typical Device Power Consumption vs fmax

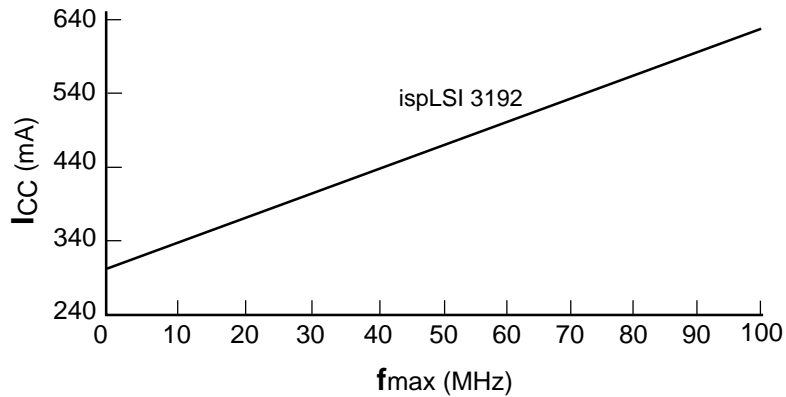

Notes: Configuration of 16 16-bit Counters
Typical Current at 5V, 25° C

ICC can be estimated for the ispLSI 3192 using the following equation:

$$I_{CC} = 50 + (\# \text{ of PTs} * 0.65) + (\# \text{ of nets} * \text{Max. freq} * 0.015) \text{ where:}$$

- # of PTs = Number of Product Terms used in design
- # of nets = Number of Signals used in device
- Max. freq = Highest Clock Frequency to the device

The ICC estimate is based on typical conditions (VCC = 5.0V, room temperature) and an assumption of 2 GLB loads on average exists. These values are for estimates only. Since the value of ICC is sensitive to operating conditions and the program in the device, the actual ICC should be verified.

0127/3192

For the ispLSI 3192-100LB272, it is strongly recommended that the actual Icc be verified to ensure that the maximum junction temperature (Tj) with power supplied is not exceeded. Depending on the specific logic design and clock speed, airflow may be required to satisfy the

maximum allowable junction temperature (Tj) specification. Please refer to the Thermal Management section of the Lattice Semiconductor Data Book or CD-ROM for additional information on calculating Tj.

Discontinued Product (PCN #06-07). Contact Rochester Electronics for Availability.
www.latticesemi.com/sales/discontinueddevicesales.cfm

NAME	PQFP PIN NUMBERS	DESCRIPTION
I/O 0 - I/O 5 I/O 6 - I/O 11 I/O 12 - I/O 17 I/O 18 - I/O 23 I/O 24 - I/O 29 I/O 30 - I/O 35 I/O 36 - I/O 41 I/O 42 - I/O 47 I/O 48 - I/O 53 I/O 54 - I/O 59 I/O 60 - I/O 65 I/O 66 - I/O 71 I/O 72 - I/O 77 I/O 78 - I/O 83 I/O 84 - I/O 89 I/O 90 - I/O 95 I/O 96 - I/O 101 I/O 102 - I/O 107 I/O 108 - I/O 113 I/O 114 - I/O 119 I/O 120 - I/O 125 I/O 126 - I/O 131 I/O 132 - I/O 137 I/O 138 - I/O 143 I/O 144 - I/O 149 I/O 150 - I/O 155 I/O 156 - I/O 161 I/O 162 - I/O 167 I/O 168 - I/O 173 I/O 174 - I/O 179 I/O 180 - I/O 185 I/O 186 - I/O 191	36, 37, 38, 39, 40, 41, 43, 44, 45, 46, 47, 48, 50, 51, 52, 53, 54, 55, 57, 58, 59, 60, 61, 62, 64, 65, 66, 67, 68, 69, 71, 72, 73, 74, 75, 76, 78, 79, 80, 81, 82, 83, 85, 86, 87, 88, 89, 90, 92, 93, 94, 95, 96, 97, 99, 100, 101, 102, 103, 104, 106, 107, 108, 109, 110, 111, 113, 114, 115, 116, 117, 118, 120, 121, 122, 123, 124, 125, 127, 128, 129, 130, 131, 132, 134, 135, 136, 137, 138, 139, 141, 142, 143, 144, 145, 146, 156, 157, 158, 159, 160, 161, 163, 164, 165, 166, 167, 168, 170, 171, 172, 173, 174, 175, 177, 178, 179, 180, 181, 182, 184, 185, 186, 187, 188, 189, 191, 192, 193, 194, 195, 196, 198, 199, 200, 201, 202, 203, 205, 206, 207, 208, 209, 210, 212, 213, 214, 215, 216, 217, 219, 220, 221, 222, 223, 224, 226, 227, 228, 229, 230, 231, 233, 234, 235, 236, 237, 238, 240, 1, 2, 3, 4, 5, 7, 8, 9, 10, 11, 12, 14, 15, 16, 17, 18, 19, 21, 22, 23, 24, 25, 26	Input/Output Pins - These are the general purpose I/O pins used by the logic array.
GOE0 and GOE1 TOE	152 and 153 154	Global Output Enable input pins. Test output enable pin. TOE tristates all I/O pins when a logic low is driven.
RESET Y0, Y1 and Y2 Y3 and Y4	33 35, 34, 148 149, 151	Active Low (0) Reset pin which resets all of the GLB and I/O registers in the device. Dedicated Clock inputs. These clock inputs are connected to one of the clock inputs of all the GLBs on the device. Dedicated Clock inputs. These clock inputs are connected to one of the clock inputs of all the I/O cells in the device.
BSCAN/ $\overline{\text{ispEN}}^2$ TDI/ SDI^2 TCK/ SCLK^2 TMS/ MODE^2 $\overline{\text{TRST}}/\text{NC}^{1,2}$ TDO/ SDO^2	32 30 29 28 155 27	Input — Dedicated in-system programming enable input pin. When this pin is high, the BSCAN TAP controller pins TMS, TDI, TDO and TCK are enabled. When this pin is brought low, the ISP state machine control pins MODE, SDI, SDO and SLCK are enabled. High-to-low transition of this pin will put the device in the programming mode and put all I/O pins in high-Z state. Input - This pin performs two functions. It is the Test Data input pin when $\overline{\text{ispEN}}$ is logic high. When $\overline{\text{ispEN}}$ is logic low, it functions as an input pin to load programming data into the device. SDI is also used as one of the two control pins for the isp state machine. Input - This pin performs two functions. It is the Test Clock input pin when $\overline{\text{ispEN}}$ is logic high. When $\overline{\text{ispEN}}$ is logic low, it functions as a clock pin for the Serial Shift Register. Input - This pin performs two functions. It is the Test Mode Select input pin when $\overline{\text{ispEN}}$ is logic high. When $\overline{\text{ispEN}}$ is logic low, it functions as pin to control the operation of the isp state machine. Input - Test Reset, active low to reset the Boundary Scan State Machine. Output - This pin performs two functions. When $\overline{\text{ispEN}}$ is logic low, it functions as the pin to read the isp data. When $\overline{\text{ispEN}}$ is high it functions as Test Data Out.
GND VCC NC ¹	13, 31, 49, 63, 77, 91, 105, 119, 133, 150, 169, 183, 197, 211, 225, 239 6, 20, 42, 56, 70, 84, 98, 112, 126, 140, 162, 176, 190, 204, 218, 232 147	Ground (GND) V _{CC} No Connect

1. NC pins are not to be connected to any active signal, Vcc or GND.
 2. Pins have dual function capability.

Table 2 - 0002/3192

NAME	BGA BALL NUMBERS	DESCRIPTION
I/O 0 - I/O 5 I/O 6 - I/O 11 I/O 12 - I/O 17 I/O 18 - I/O 23 I/O 24 - I/O 29 I/O 30 - I/O 35 I/O 36 - I/O 41 I/O 42 - I/O 47 I/O 48 - I/O 53 I/O 54 - I/O 59 I/O 60 - I/O 65 I/O 66 - I/O 71 I/O 72 - I/O 77 I/O 78 - I/O 83 I/O 84 - I/O 89 I/O 90 - I/O 95 I/O 96 - I/O 101 I/O 102 - I/O 107 I/O 108 - I/O 113 I/O 114 - I/O 119 I/O 120 - I/O 125 I/O 126 - I/O 131 I/O 132 - I/O 137 I/O 138 - I/O 143 I/O 144 - I/O 149 I/O 150 - I/O 155 I/O 156 - I/O 161 I/O 162 - I/O 167 I/O 168 - I/O 173 I/O 174 - I/O 179 I/O 180 - I/O 185 I/O 186 - I/O 191	M4, N1, N2, N3, P1, P2 P3, R2, T1, P4, R3, T2 T3, U2, V1, T4, U3, V2 V3, W2, Y1, W3, Y2, W4 U5, Y3, Y4, V5, W5, Y5 U7, W6, Y6, V7, W7, Y7 V8, W8, Y8, U9, V9, W9 W10, V10, Y10, Y11, W11, V11 U11, Y12, W12, V12, U12, Y13 V13, Y14, W14, Y15, V14, W15 Y16, U14, V15, W16, Y17, V16 Y18, U16, V17, W18, Y19, V18 Y20, W20, V19, U19, U18, T17 U20, T18, T19, T20, R18, P17 R20, P18, P19, P20, N18, N19 M17, M18, M19, M20, L19, L18 J17, H20, H19, H18, G20, G19 G18, F19, E20, G17, F18, E19 E18, D19, C20, E17, D18, C19 C18, B19, A20, A19, B18, B17 D16, A18, A17, C16, B16, A16 D14, B15, A15, C14, B14, A14 C13, B13, A13, D12, C12, B12 B11, C11, A11, A10, B10, C10 D10, A9, B9, C9, D9, A8 C8, A7, B7, A6, C7, B6 A5, D7, C6, B5, A4, C5 A3, D5, C4, B3, B2, A2 C3, B1, C2, D2, D3, E4 D1, E3, E2, E1, F3, G4 F1, G3, G2, G1, H3, H2 J4, J3, J2, J1, K2, K3	Input/Output Pins - These are the general purpose I/O pins used by the logic array.
GOE0 and GOE1 TOE	K17 and J20 J19	Global Output Enable input pins. Test output enable pin. TOE tristates all I/O pins when a logic low is driven.
RESET	M1	Active Low (0) Reset pin which resets all of the GLB and I/O registers in the device.
Y0, Y1 and Y2 Y3 and Y4	M3, M2, L20 K20, K18	Dedicated Clock inputs. These clock inputs are connected to one of the clock inputs of all the GLBs on the device. Dedicated Clock inputs. These clock inputs are connected to one of the clock inputs of all the I/O cells in the device.
BSCAN/ $\overline{\text{ispEN}}^2$	L4	Input - Dedicated in-system programming enable input pin. When this pin is high, the BSCAN TAP controller pins TMS, TDI, TDO and TCK are enabled. When this pin is brought low, the ISP state machine control pins MODE, SDI, SDO and SLCK are enabled. High-to-low transition of this pin will put the device in the programming mode and put all I/O pins in high-Z state.
TDI/SDI ²	L3	Input - This pin performs two functions. It is the Test Data input pin when $\overline{\text{ispEN}}$ is logic high. When $\overline{\text{ispEN}}$ is logic low, it functions as an input pin to load programming data into the device. SDI is also used as one of the two control pins for the isp state machine.
TCK/SCLK ²	L2	Input - This pin performs two functions. It is the Test Clock input pin when $\overline{\text{ispEN}}$ is logic high. When $\overline{\text{ispEN}}$ is logic low, it functions as a clock pin for the Serial Shift Register.
TMS/MODE ²	L1	Input - This pin performs two functions. It is the Test Mode Select input pin when $\overline{\text{ispEN}}$ is logic high. When $\overline{\text{ispEN}}$ is logic low, it functions as pin to control the operation of the isp state machine.
$\overline{\text{TRST}}/\text{NC}^1, 2$	J18	Input - Test Reset, active low to reset the Boundary Scan State Machine.
TDO/SDO ²	K1	Output - This pin performs two functions. When $\overline{\text{ispEN}}$ is logic low, it functions as the pin to read the isp data. When $\overline{\text{ispEN}}$ is high it functions as Test Data Out.
GND	A1, D4, D8, D13, D17, H4, H17, J9, J10, J11, J12, K9, K10, K11, K12, L9, L10, L11, L12, M9, M10, M11, M12, N4, N17, U4, U8, U13, U17	Ground (GND)
VCC	D6, D11, D15, F4, F17, K4, L17, R4, R17, U6, U10, U15	V _{CC}
NC	A12, B4, B8, B20, C1, C15, C17, D20, F2, F20, H1, K19, N20, R1, R19, U1, V4, V6, V20, W1, W13, W17, W19, Y9	No Connect

1. NC pins are not to be connected to any active signal, Vcc or GND.
 2. Pins have dual function capability.

Table 2 - 0002/3192.BGA

ispLSI 3192 240-pin PQFP

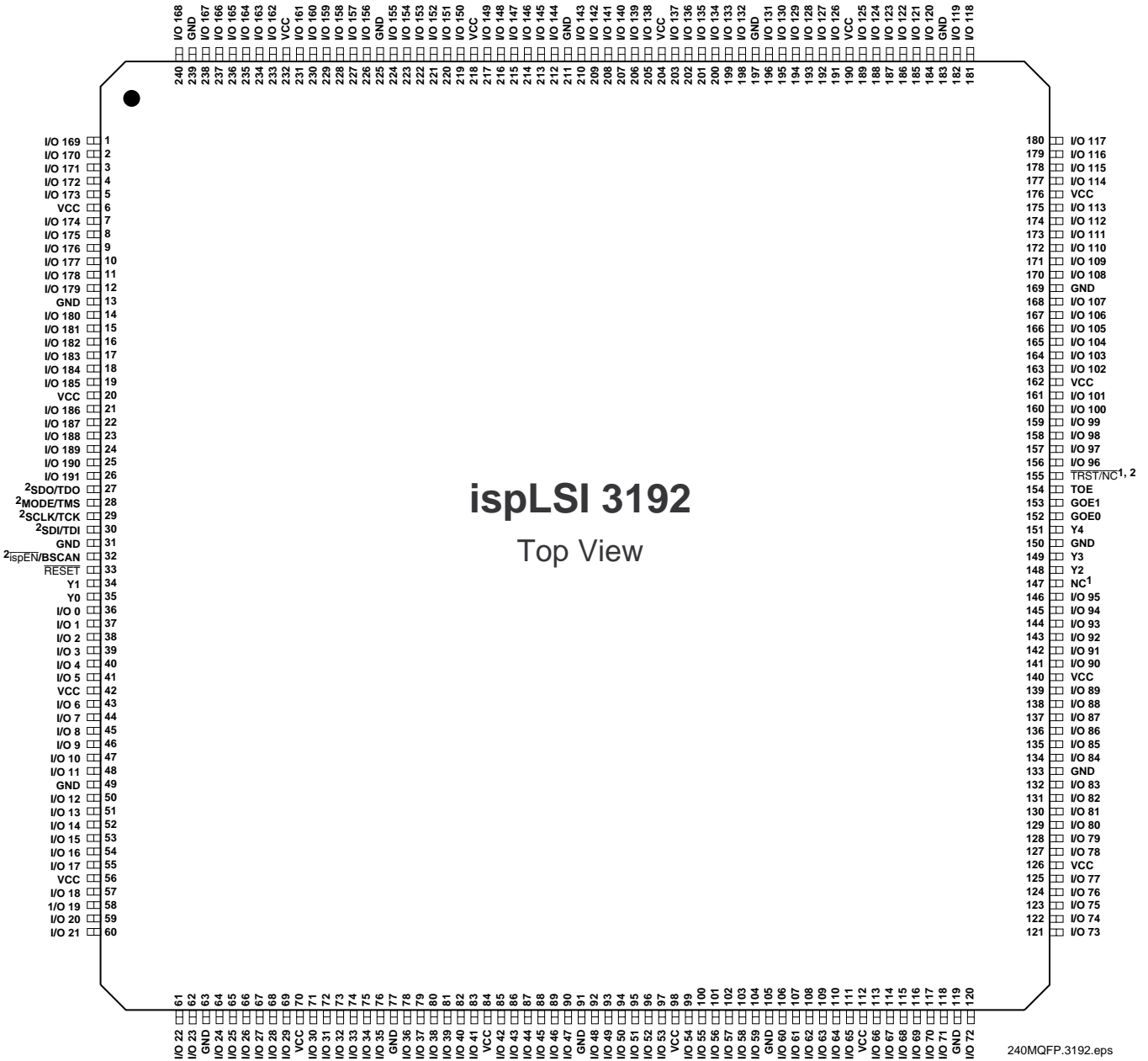

ispLSI 3192
Top View

240MQFP.3192.eps

1. NC pins are not to be connected to any active signal, Vcc or GND.
2. Pins have dual function capability.

Discontinued Product (PCN #06-07). Contact Rochester Electronics for Availability.
www.latticesemi.com/sales/discontinueddevicesales.cfm

ispLSI 3192 272-Ball BGA

Discontinued Product (PCN #06-07). Contact Rochester Electronics for Availability.
www.latticesemi.com/sales/discontinueddevicesales.cfm

	20	19	18	17	16	15	14	13	12	11	10	9	8	7	6	5	4	3	2	1																	
A	I/O 116	I/O 117	I/O 121	I/O 122	I/O 125	I/O 128	I/O 131	I/O 134	NC ¹	I/O 140	I/O 141	I/O 145	I/O 149	I/O 151	I/O 153	I/O 156	I/O 160	I/O 162	I/O 167	GND	A																
B	NC ¹	I/O 115	I/O 118	I/O 119	I/O 124	I/O 127	I/O 130	I/O 133	I/O 137	I/O 138	I/O 142	I/O 146	NC ¹	I/O 152	I/O 155	I/O 159	NC ¹	I/O 165	I/O 166	I/O 169	B																
C	I/O 110	I/O 113	I/O 114	NC ¹	I/O 123	NC ¹	I/O 129	I/O 132	I/O 136	I/O 139	I/O 143	I/O 147	I/O 150	I/O 154	I/O 158	I/O 161	I/O 164	I/O 168	I/O 170	NC ¹	C																
D	NC ¹	I/O 109	I/O 112	GND	I/O 120	VCC	I/O 126	GND	I/O 135	VCC	I/O 144	I/O 148	GND	I/O 157	VCC	I/O 163	GND	I/O 172	I/O 171	I/O 174	D																
E	I/O 104	I/O 107	I/O 108	I/O 111	ispLSI 3192 Bottom View <table border="1" style="margin: auto;"> <tr><td>GND</td><td>GND</td><td>GND</td><td>GND</td></tr> <tr><td>GND</td><td>GND</td><td>GND</td><td>GND</td></tr> <tr><td>GND</td><td>GND</td><td>GND</td><td>GND</td></tr> <tr><td>GND</td><td>GND</td><td>GND</td><td>GND</td></tr> </table>												GND	GND	GND	GND	GND	GND	GND	GND	GND	GND	GND	GND	GND	GND	GND	GND	I/O 173	I/O 175	I/O 176	I/O 177	E
GND	GND	GND	GND																																		
GND	GND	GND	GND																																		
GND	GND	GND	GND																																		
GND	GND	GND	GND																																		
F	NC ¹	I/O 103	I/O 106	VCC													I/O 178	NC ¹	I/O 180	F																	
G	I/O 100	I/O 101	I/O 102	I/O 105													I/O 179	I/O 181	I/O 182	I/O 183	G																
H	I/O 97	I/O 98	I/O 99	GND													GND	I/O 184	I/O 185	NC ¹	H																
J	GOE1	TOE	TRST / NC ¹	I/O 96													I/O 186	I/O 187	I/O 188	I/O 189	J																
K	Y3	NC ¹	Y4	GOE0													VCC	I/O 191	I/O 190	SDO / TDO	K																
L	Y2	I/O 94	I/O 95	VCC	ispEN / BSCAN	SDI / TDI	SCLK / TCK	MODE / TMS	L																												
M	I/O 93	I/O 92	I/O 91	I/O 90	I/O 0	Y0	Y1	RESET	M																												
N	NC ¹	I/O 89	I/O 88	GND	GND	I/O 3	I/O 2	I/O 1	N																												
P	I/O 87	I/O 86	I/O 85	I/O 83	I/O 9	I/O 6	I/O 5	I/O 4	P																												
R	I/O 84	NC ¹	I/O 82	VCC	VCC	I/O 10	I/O 7	NC ¹	R																												
T	I/O 81	I/O 80	I/O 79	I/O 77	I/O 15	I/O 12	I/O 11	I/O 8	T																												
U	I/O 78	I/O 75	I/O 76	GND	I/O 67	VCC	I/O 61	GND	I/O 52	I/O 48	VCC	I/O 39	GND	I/O 30	VCC	I/O 24	GND	I/O 16	I/O 13	NC ¹	U																
V	NC ¹	I/O 74	I/O 71	I/O 68	I/O 65	I/O 62	I/O 58	I/O 54	I/O 51	I/O 47	I/O 43	I/O 40	I/O 36	I/O 33	NC ¹	I/O 27	NC ¹	I/O 18	I/O 17	I/O 14	V																
W	I/O 73	NC ¹	I/O 69	NC ¹	I/O 63	I/O 59	I/O 56	NC ¹	I/O 50	I/O 46	I/O 42	I/O 41	I/O 37	I/O 34	I/O 31	I/O 28	I/O 23	I/O 21	I/O 19	NC ¹	W																
Y	I/O 72	I/O 70	I/O 66	I/O 64	I/O 60	I/O 57	I/O 55	I/O 53	I/O 49	I/O 45	I/O 44	NC ¹	I/O 38	I/O 35	I/O 32	I/O 29	I/O 26	I/O 25	I/O 22	I/O 20	Y																
	20	19	18	17	16	15	14	13	12	11	10	9	8	7	6	5	4	3	2	1																	

1. NC's are not to be connected to any active signals, Vcc or GND.

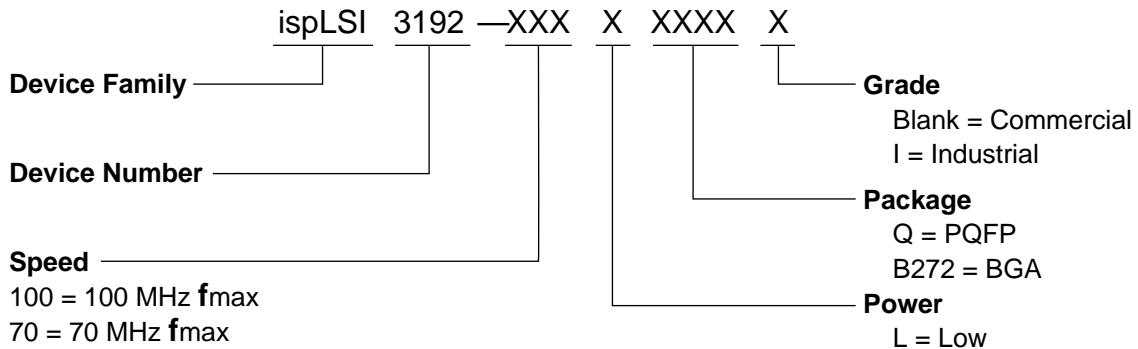

0212/3192

COMMERCIAL

Family	f_{max}	tpd	Ordering Number	Package
ispLSI	100	10	ispLSI 3192-100LQ	240-Pin PQFP
	100	10	ispLSI 3192-100LB272	272-Ball BGA
	70	15	ispLSI 3192-70LQ	240-Pin PQFP
	70	15	ispLSI 3192-70LB272	272-Ball BGA

Table 2- 0041/3192

INDUSTRIAL

Family	f_{max}	tpd	Ordering Number	Package
ispLSI	70	15	ispLSI 3192-70LQI	240-Pin PQFP

Table 2- 0042/3192

Discontinued Product (PCN #06-07). Contact Rochester Electronics for Availability.
www.latticesemi.com/sales/discontinueddevicesales.cfm