



Photocoupler

Product Data Sheet

LTV-3150 series

Spec No.: DS70-2012-0059

Effective Date: 04/23/2014

Revision: A

LITE-ON DCC

RELEASE

BNS-OD-FC001/A4

Photocouplers LTV-3150 series

1. DESCRIPTION

The LTV-3150 optocoupler is ideally suited for driving power IGBTs and MOSFETs used in motor control inverter applications and inverters in power supply system. It contains an AlGaAs LED optically coupled to an integrated circuit with a power output stage. The 1.0A peak output current is capable of directly driving most IGBTs with ratings up to 1200 V/50 A. For IGBTs with higher ratings, the LTV-3150 series can be used to drive a discrete power stage which drives the IGBT gate.

The Optocoupler operational parameters are guaranteed over the temperature range from $-40^{\circ}\text{C} \sim +105^{\circ}\text{C}$.

1.1 Features

- 1.0 A maximum peak output current
- 0.8A minimum peak output current
- Rail-to-rail output voltage
- 400 ns maximum propagation delay
- 150 ns maximum propagation delay difference
- Under Voltage Lock-Out protection (UVLO) with hysteresis
- 15 kV/us minimum Common Mode Rejection (CMR) at $V_{CM} = 1500 \text{ V}$
- $I_{CC} = 3.0 \text{ mA}$ maximum supply current
- Wide operating range: 15 to 30 Volts (V_{CC})
- Guaranteed performance over temperature $-40^{\circ}\text{C} \sim +105^{\circ}\text{C}$.
- Offer low power dissipation with $R_{ON} \leq 1\Omega$
- MSL Level 1
- Safety approval:
 - UL/ cUL Recognized 5000 $V_{RMS}/1 \text{ min}$
 - IEC/EN/DIN EN 60747-5-5 $V_{IORM} = 630 \text{ Vpeak}$

1.2 Applications

- IGBT/MOSFET gate drive
- Uninterruptible power supply (UPS)
- Industrial Inverter
- AC/Brushless DC motor drives

Functional Diagram

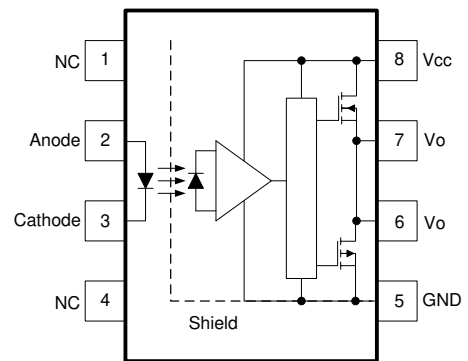

A $0.1\mu\text{F}$ bypass Capacitor must be connected between Pin 5 and 8. See note 11.

Truth Table

LED	V_{CC-GND} (Turn-ON, +ve going)	V_{CC-GND} (Turn-OFF, -ve going)	V_O
OFF	0 - 30 V	0 - 30 V	Low
ON	0 - 11 V	0 - 9 V	Low
ON	11 - 13.5 V	9 - 12 V	Transition
ON	13.5 - 30 V	12 - 30 V	High

Photocouplers LTV-3150 series

2. PACKAGE DIMENSIONS

2.1 LTV-3150

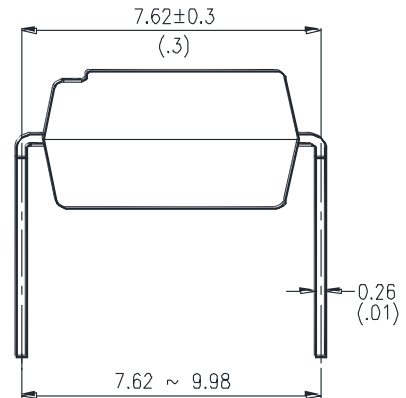
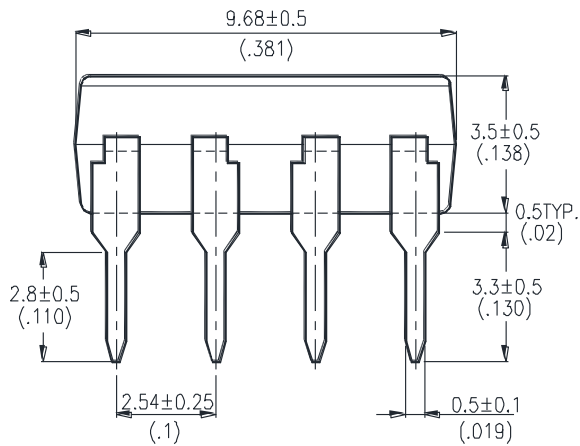
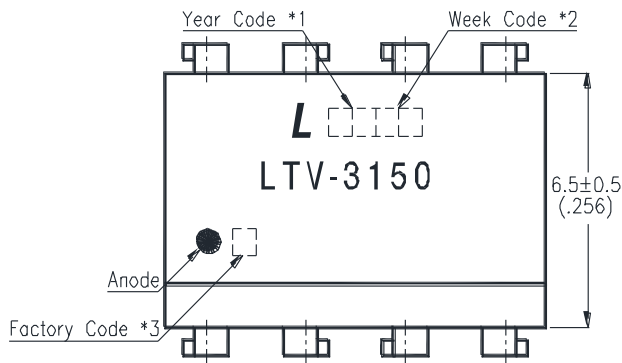

Notes :

- *1. Year date code.
- *2. 2-digit work week.
- *3. Factory identification mark
(Y : Thailand).

Dimensions are in Millimeters and (Inches).

Photocouplers LTV-3150 series

2.2 LTV-3150M

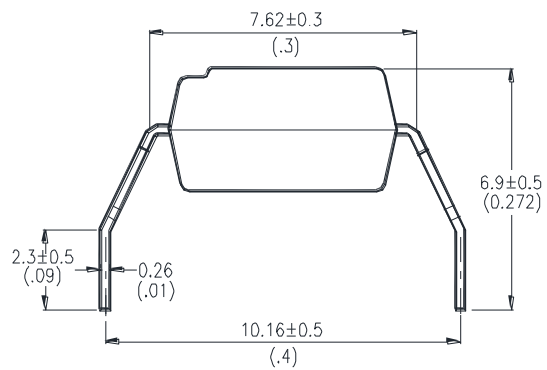
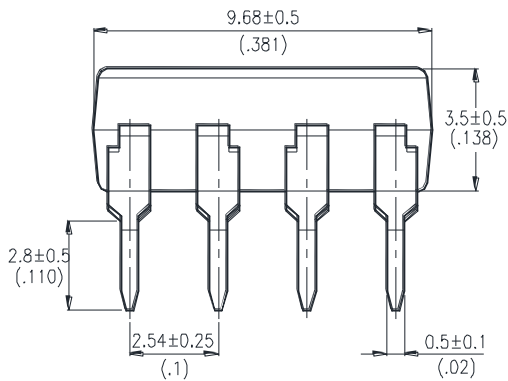
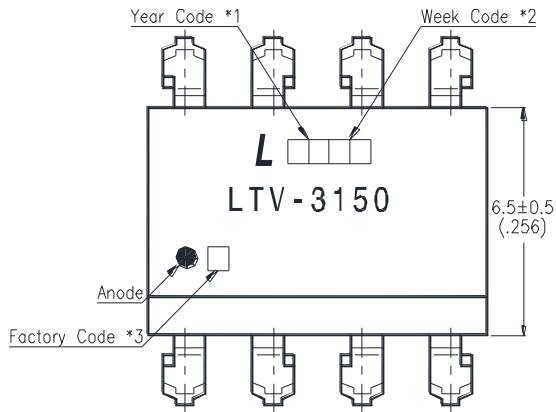

Notes

- *1. Year date code.
- *2. 2-digit work week.
- *3. Factory identification mark
(Y : Thailand).

Dimensions are in Millimeters and (Inches).

Photocouplers LTV-3150 series

2.3 LTV-3150S

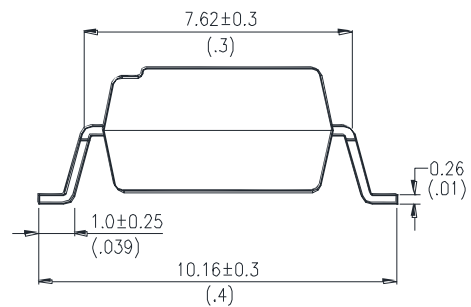
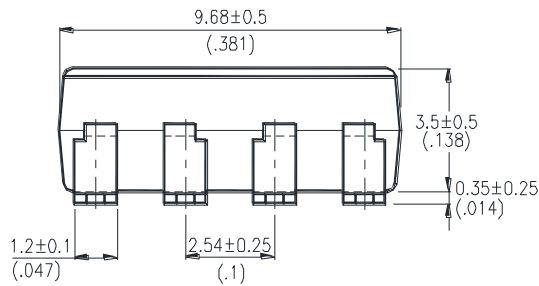
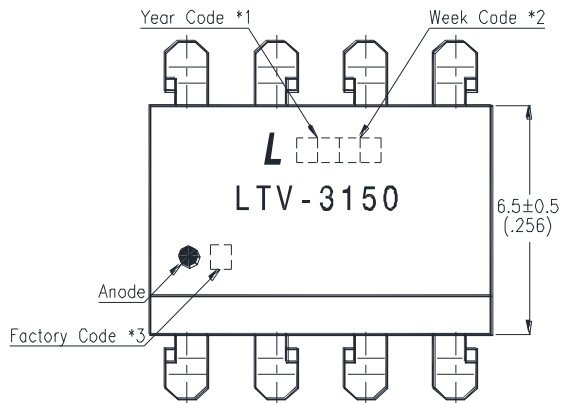

Notes :

- *1. Year date code.
- *2. 2-digit work week.
- *3. Factory identification mark
(Y : Thailand).

Dimensions are in Millimeters and (Inches).

Photocouplers LTV-3150 series

3. TAPING DIMENSIONS

3.1 LTV-3150S-TA

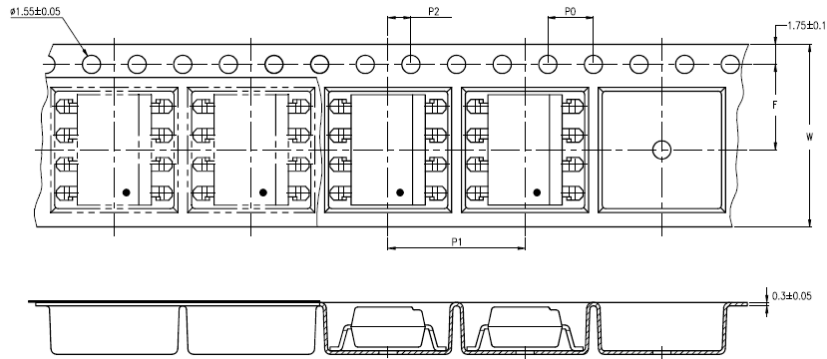

3.2 LTV-3150S-TA1

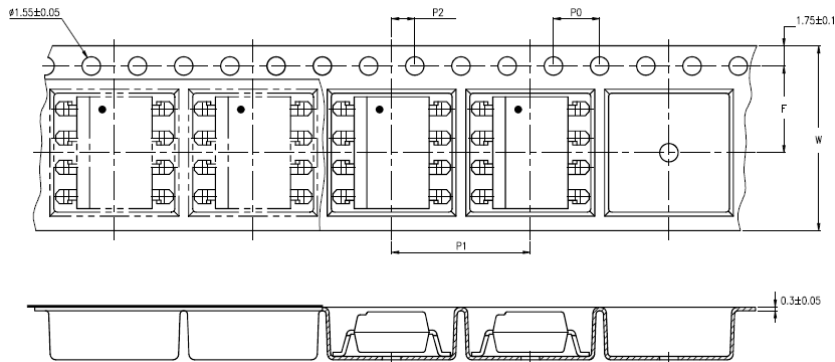

Description	Symbol	Dimension in mm (inch)
Tape wide	W	16±0.3 (0.63)
Pitch of sprocket holes	P_0	4±0.1 (0.15)
Distance of compartment	F	7.5±0.1 (0.295)
	P_2	2±0.1 (0.079)
Distance of compartment to compartment	P_1	12±0.1 (0.47)

Quantities Per Reel

Package Type	LTV-3150
Quantities (pcs)	1000

Photocouplers LTV-3150 series

4. RATING AND CHARACTERISTICS

4.1 Absolute Maximum Ratings

Parameter	Symbol	Min	Max	Unit	Note
Storage Temperature	T_{stg}	-55	+125	°C	
Operating Temperature	T_{opr}	-40	+105	°C	
Output IC Junction Temperature	T_J		125	°C	
Isolation Voltage	V_{iso}	5000		V_{RMS}	
Total Output Supply Voltage	$(V_{CC} - V_{EE})$	0	35	V	
Average Forward Input Current	I_F		25	mA	
Reverse Input Voltage	V_R		5	V	
Peak Transient Input Current ($<1 \mu s$ pulse width, 300 pps)	$I_{F(TRAN)}$		1	A	
“High” Peak Output Current	$I_{OH(PEAK)}$		1.0	A	1
“Low” Peak Output Current	$I_{OL(PEAK)}$		1.0	A	1
Input Current (Rise/Fall Time)	$t_{r(IN)} / t_{f(IN)}$		500	ns	
Output Voltage	$V_{O(PEAK)}$	-0.5	V_{CC}	V	
Power Dissipation	P_I		40	mW	
Output Power Dissipation	P_O		250	mW	
Total Power Dissipation	P_T		295	mW	
Lead Solder Temperature	T_{sol}		260	°C	

Ambient temperature = 25°C, unless otherwise specified. Stresses exceeding the absolute maximum ratings can cause permanent damage to the device. Exposure to absolute maximum ratings for long periods of time can adversely affect reliability.

4.2 Recommended Operating Conditions

Parameter	Symbol	Min	Max	Unit
Operating Temperature	T_A	-40	105	°C
Supply Voltage	V_{CC}	15	30	V
Input Current (ON)	$I_{FL(ON)}$	7	16	mA
Input Voltage (OFF)	$V_{F(OFF)}$	-3.0	0.8	V

Photocouplers LTV-3150 series

4.3 ELECTRICAL OPTICAL CHARACTERISTICS

	Parameter	Symbol	Min.	Typ.	Max.	Unit	Test Condition	Figure	Note
Input	Input Forward Voltage	V_F	1.2	1.37	1.8	V	$I_F = 10\text{mA}$	13	
	Input Forward Voltage Temperature Coefficient	$\Delta V_F / \Delta T$		-1.237		mV/°C	$I_F = 10\text{mA}$		
	Input Reverse Voltage	BV_R	5			V	$I_R = 10\mu\text{A}$		
	Input Threshold Current (Low to High)	I_{FLH}		1.4	5	mA	$R_g = 10\Omega$, $C_g = 25\text{nF}$, $V_O > 5\text{V}$	6, 7,18	
	Input Threshold Voltage (High to Low)	V_{FHL}	0.8			V			
	Input Capacitance	C_{IN}		33		pF	$f = 1\text{MHz}$, $V_F = 0\text{V}$		
Output	High Level Supply Current	I_{CCH}		1.9	3.0	mA	$R_g = 10\Omega$, $C_g = 25\text{nF}$, $I_F = 10\text{mA}$	4, 5	
	Low Level Supply Current	I_{CCL}		2.1	3.0	mA	$R_g = 10\Omega$, $C_g = 25\text{nF}$, $V_F = 0\text{V}$		
	High level output current	I_{OH}			-0.3	A	$V_O = (V_{CC} - 2.5\text{V})$	16	1
				-	-0.8		$V_{CC} - V_O \leq 15\text{V}$		2
	Low level output current	I_{OL}	0.3			A	$V_O = (V_{CC} + 2.0\text{V})$	17	1
			0.8				$V_{CC} - V_{EE} \leq 15\text{V}$		3
	High level output voltage	V_{OH}	$V_{CC} - 0.25$	$V_{CC} - 0.1$		V	$I_F = 10\text{mA}$, $I_O = -100\text{mA}$	1, 2, 14	4
	Low level output voltage	V_{OL}		$V_{EE} + 0.1$	$V_{EE} + 0.25$	V	$I_F = 0\text{mA}$, $I_O = 100\text{mA}$	3, 15	
	UVLO Threshold	V_{UVLO+}	11.0	12.7	13.5	V	$V_O > 5\text{V}$, $I_F = 10\text{mA}$	19	
V_{UVLO-}		9.0	11.2	12	V	$V_O < 5\text{V}$, $I_F = 10\text{mA}$			
UVLO Hysteresis	$UVLO_{HYS}$		1.5		V				

All Typical values at $T_A = 25^\circ\text{C}$ and $V_{CC} - V_{EE} = 30\text{V}$, unless otherwise specified; all minimum and maximum specifications are at recommended operating condition. (As page 6)

Photocouplers LTV-3150 series

5. SWITCHING SPECIFICATION

Parameter	Symbol	Min.	Typ.	Max.	Unit	Test Condition	Figure	Note
Propagation Delay Time to High Output Level	t_{PHL}	100	242	400	ns	$R_g = 10\Omega$, $C_g = 25nF$, $f = 20\text{ kHz}$, Duty Cycle = 50% $I_F = 7\text{ to }16\text{ mA}$, $V_{CC} = 15\text{ to }30V$ $V_{EE} = \text{ground}$	8, 9, 10, 11, 12, 20	
Propagation Delay Time to Low Output Level	t_{PLH}	100	183	400				
Pulse Width Distortion	PWD		-60	-120				10
Propagation delay difference between any two parts or channels	PDD	-150		150			7	
Output Rise Time (20 to 80%)	T_r		42				20	
Output Fall Time (80 to 20%)	T_f		50					
Common mode transient immunity at high level output	CMH	15			KV/ μ s	$T_A = 25^\circ\text{C}$, $I_F = 10\text{ to }16\text{ mA}$, $V_{CM} = 1500\text{ V}$, $V_{CC} = 30\text{ V}$	21	8
Common mode transient immunity at low level output	CML	15			KV/ μ s	$T_A = 25^\circ\text{C}$, $V_F = 0\text{ V}$, $V_{CM} = 1500\text{ V}$, $V_{CC} = 30\text{ V}$		9

All Typical values at $T_A = 25^\circ\text{C}$ and $V_{CC} - V_{EE} = 30\text{ V}$, unless otherwise specified; all minimum and maximum specifications are at recommended operating condition. (As page 6)

Photocouplers LTV-3150 series

6. ISOLATION CHARACTERISTIC

Parameter	Symbol	Min.	Typ.	Max.	Unit	Test Condition	Note
Withstand Insulation Test Voltage	V_{ISO}	5000	—	—	V	$RH \leq 50\%$, $t = 1\text{min}$, $T_A = 25^\circ\text{C}$	5, 6
Input-Output Resistance	R_{I-O}	—	6.5×10^{11}	—	Ω	$V_{I-O} = 500\text{V DC}$	5
Input-Output Capacitance	C_{I-O}	—	1.0	—	pF	$f = 1\text{MHz}$	

All Typical values at $T_A = 25^\circ\text{C}$ unless otherwise specified. All minimum and maximum specifications are at recommended operating condition. (As page 6)

Notes:

- 1) Maximum pulse width = $10\mu\text{s}$, maximum duty cycle = 0.2%.
- 2) Output is sourced at -0.8 A with a maximum pulse width = $10\mu\text{s}$. $V_{CC}-V_O$ is measured to ensure 15 V or below.
- 3) Output is sourced at 0.8A with a maximum pulse width = $10\mu\text{s}$. V_O-V_{EE} is measured to ensure 15 V or below.
- 4) In this test V_{OH} is measured with a DC load current. When driving capacitive loads, V_{OH} will approach V_{CC} as I_{OH} approaches zero amps.
- 5) Device is considered a two terminal device: pins 1, 2, 3 and 4 are shorted together and pins 5, 6, 7 and 8 are shorted together.
- 6) According to UL1577, each photocoupler is tested by applying an insulation test voltage $5250 V_{RMS}$ for one second (leakage current less than $10\mu\text{A}$). This test is performed before the 100% production test for partial discharge
- 7) The difference between T_{PHL} and T_{PLH} between any two LTV-3150 parts under same test conditions.
- 8) Common mode transient immunity in high stage is the maximum tolerable negative dV_{CM}/dt on the trailing edge of the common mode impulse signal, V_{CM} , to assure that the output will remain high.
- 9) Common mode transient immunity in low stage is the maximum tolerable positive dV_{CM}/dt on the leading edge of the common mode impulse signal, V_{CM} , to assure that the output will remain low.
- 10) Pulse Width Distortion is defined as $T_{PHL} - T_{PLH}$ for any given device.
- 11) At least a $0.1\mu\text{F}$ or bigger bypass capacitor must be connected/ closed across pin 8 and pin 5. Failure to provide the bypass may impair the switching property. Normally, it is recommended to place a $1\mu\text{F}$ multi-layer ceramic capacitor. To parallel one larger capacitor ($>1\mu\text{F}$) to optimize performance is better.

Photocouplers LTV-3150 series

7. TYPICAL PERFORMANCE CURVES & TEST CIRCUITS

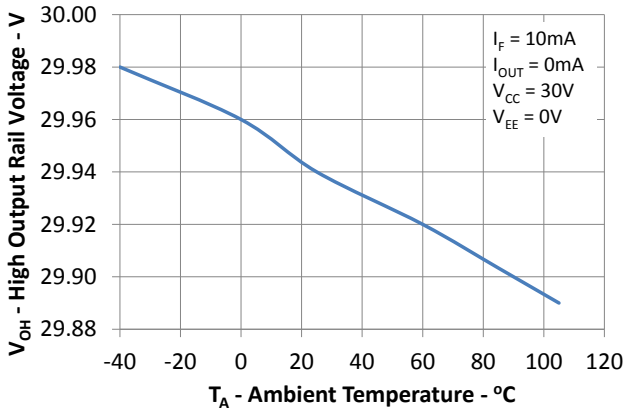

Figure 1: High output rail voltage vs. Temperature

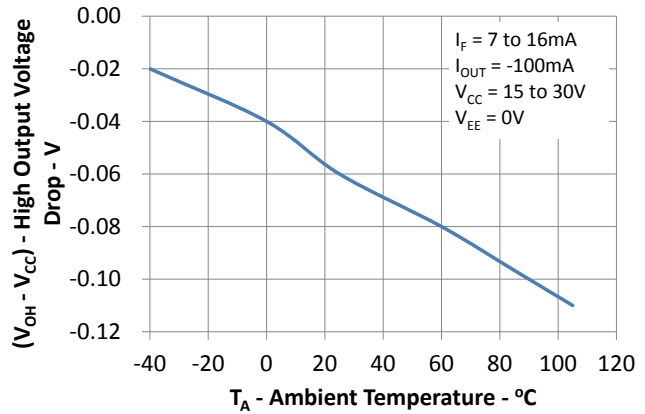

Figure 2: V_{OH} vs. Temperature

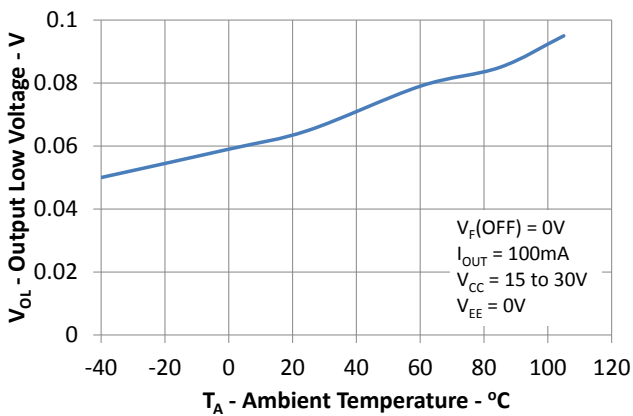

Figure 3: V_{OL} vs. High Current

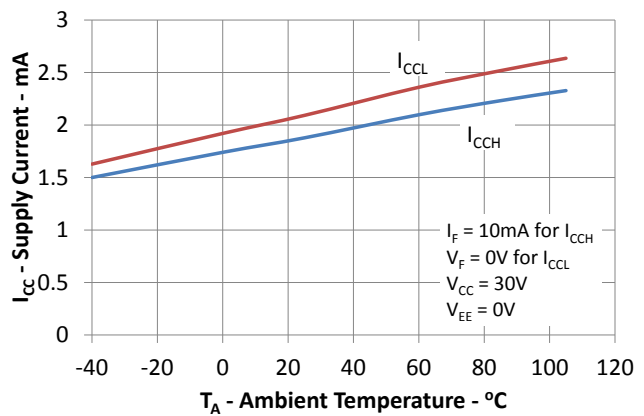

Figure 4: I_{CC} vs. Temperature

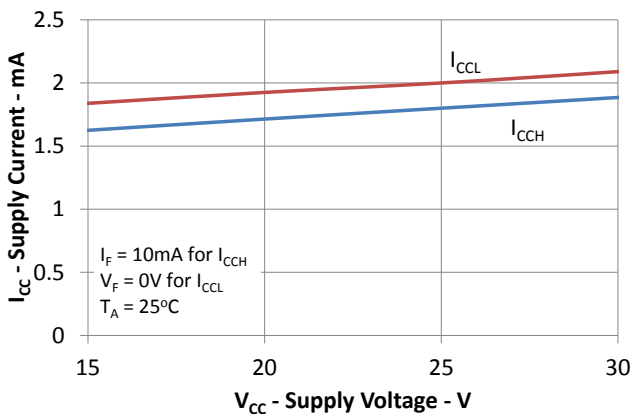

Figure 5: I_{CC} vs. V_{CC}

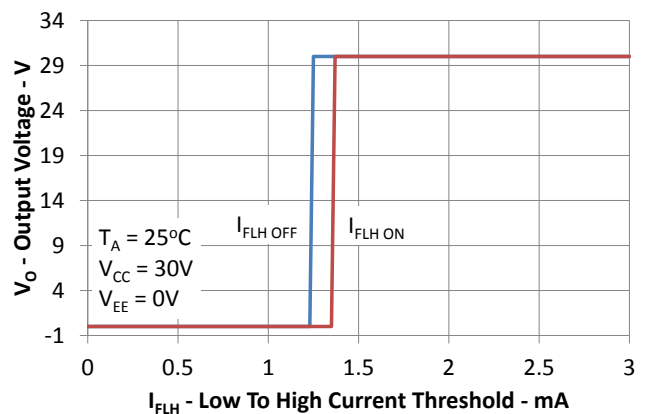

Figure 6: IFLH Hysteresis

Photocouplers LTV-3150 series

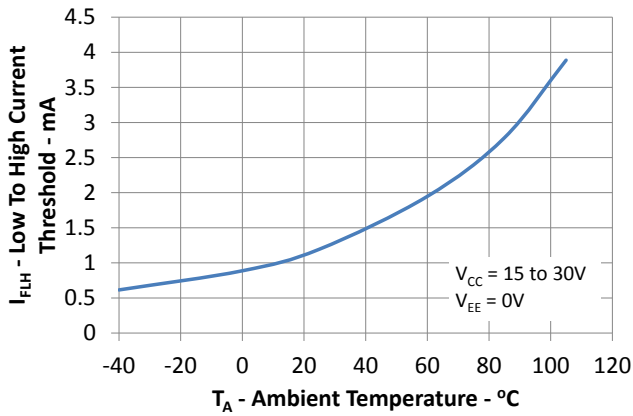

Figure 7: I_{FLH} vs. Temperature

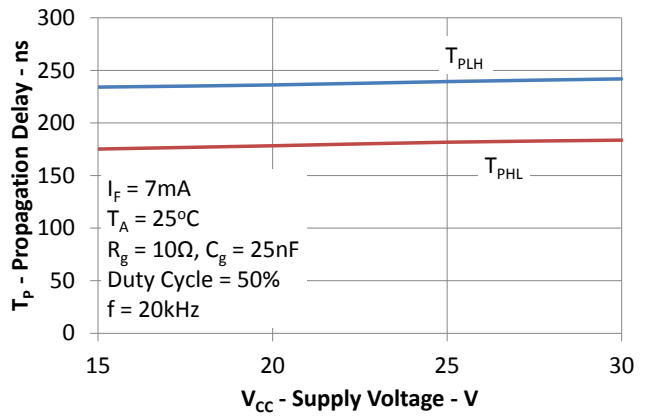

Figure 8: Propagation Delays vs. V_{CC}

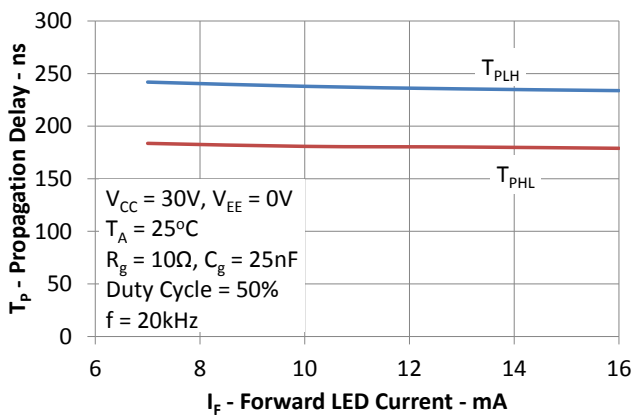

Figure 9: Propagation Delays vs. I_F

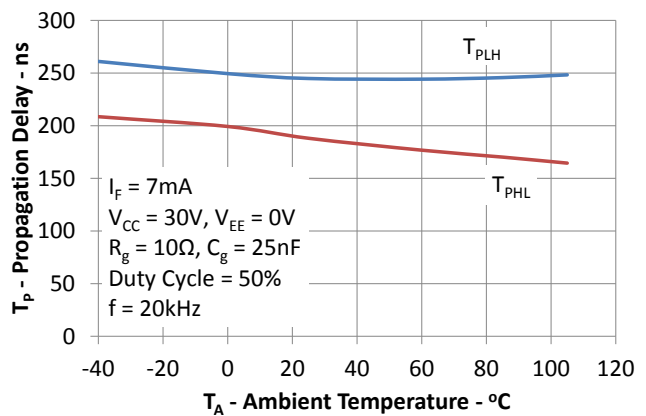

Figure 10: Propagation Delays vs. Temperature

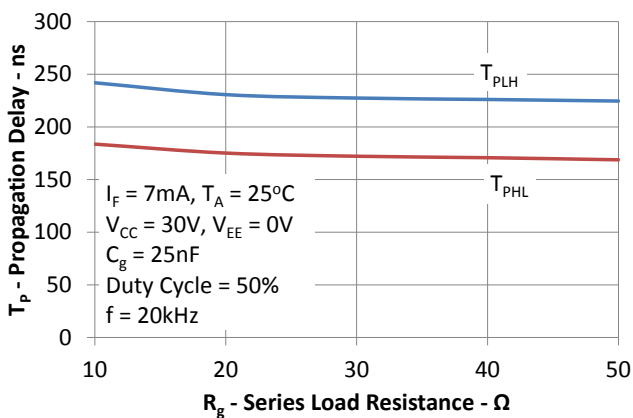

Figure 11: Propagation Delays vs. R_g

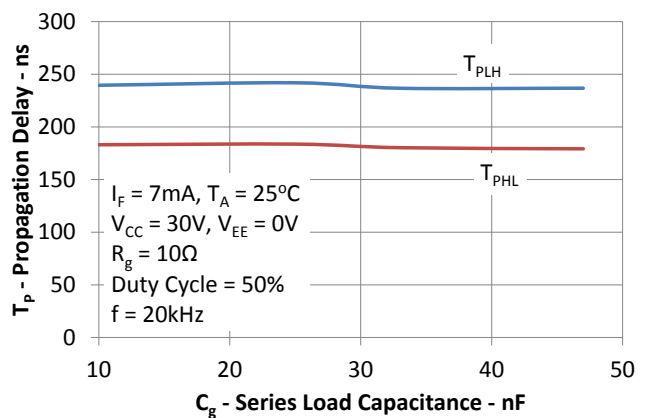

Figure 12: Propagation Delays vs. C_g

Photocouplers LTV-3150 series

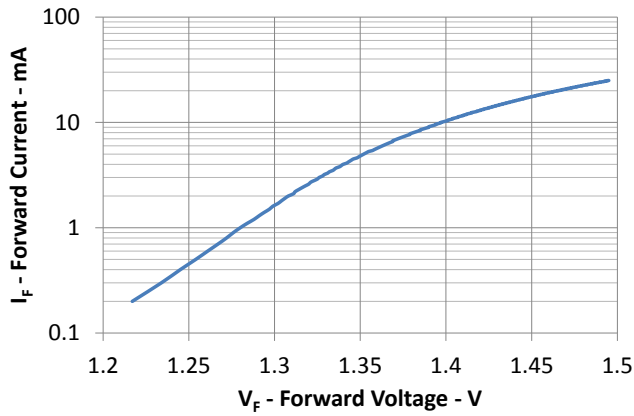

Figure 13: Input Current vs. Forward Voltage

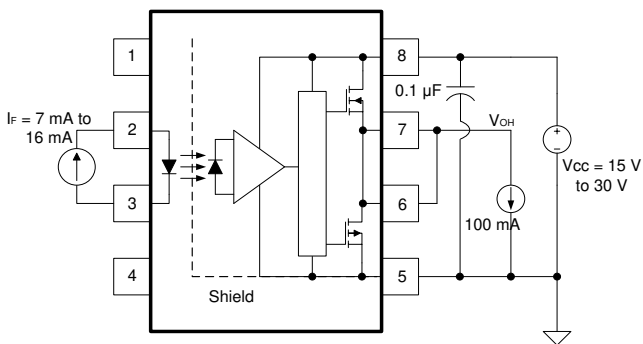

Figure 14 : V_{OH} Test Circuit

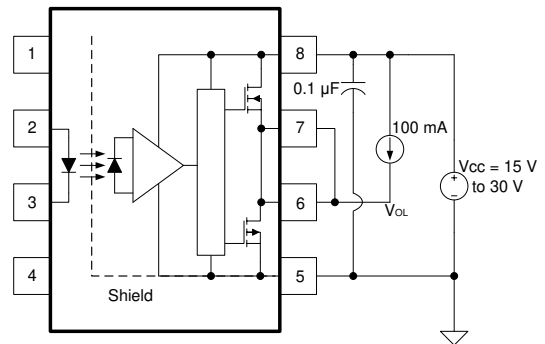

Figure 15 : V_{OL} Test Circuit

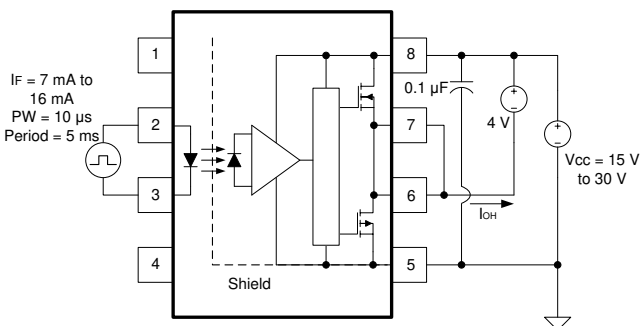

Figure 16 : I_{OH} Test Circuit

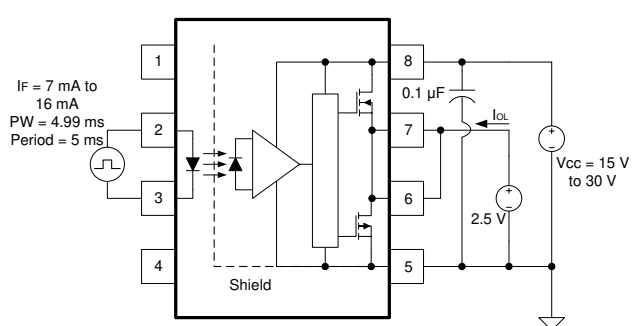

Figure 17 : I_{OL} Test Circuit

Photocouplers LTV-3150 series

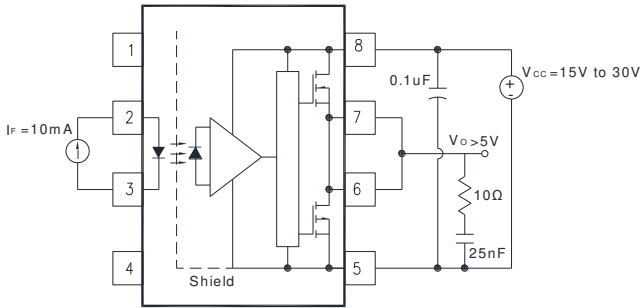

Figure 18 : IFLH Test Circuit

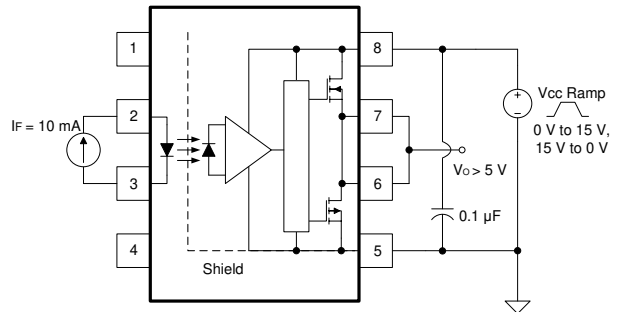

Figure 19 : UVLO Test Circuit

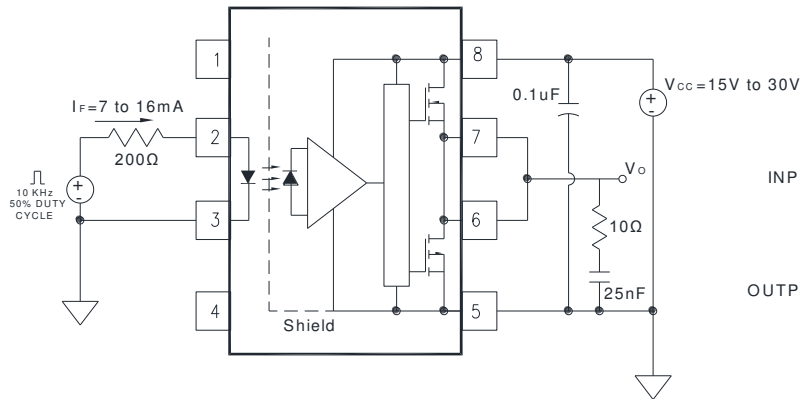

Figure 20 : t_r , t_f , t_{PLH} and t_{PHL} Test Circuit and Waveforms

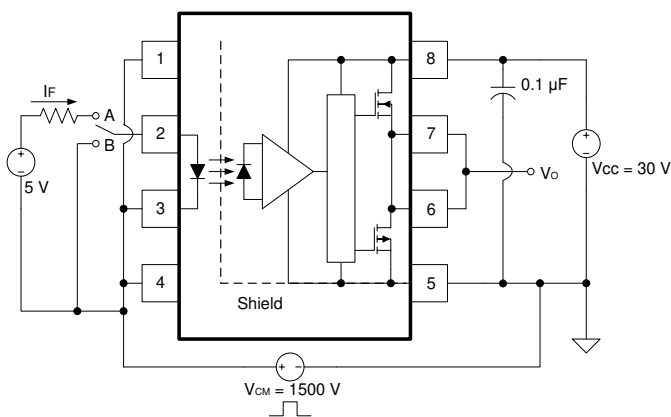

Figure 21 : CMR Test Circuit and Waveforms

Photocouplers LTV-3150 series

8. TEMPERATURE PROFILE OF SOLDERING

8.1 IR Reflow soldering (JEDEC-STD-020C compliant)

One time soldering reflow is recommended within the condition of temperature and time profile shown below. Do not solder more than three times.

Profile item	Conditions
Preheat	
- Temperature Min (T_{Smin})	150°C
- Temperature Max (T_{Smax})	200°C
- Time (min to max) (ts)	90±30 sec
Soldering zone	
- Temperature (T_L)	217°C
- Time (t_L)	60 ~ 100 sec
Peak Temperature (T_P)	260°C
Ramp-up rate	3°C / sec max.
Ramp-down rate	3~6°C / sec

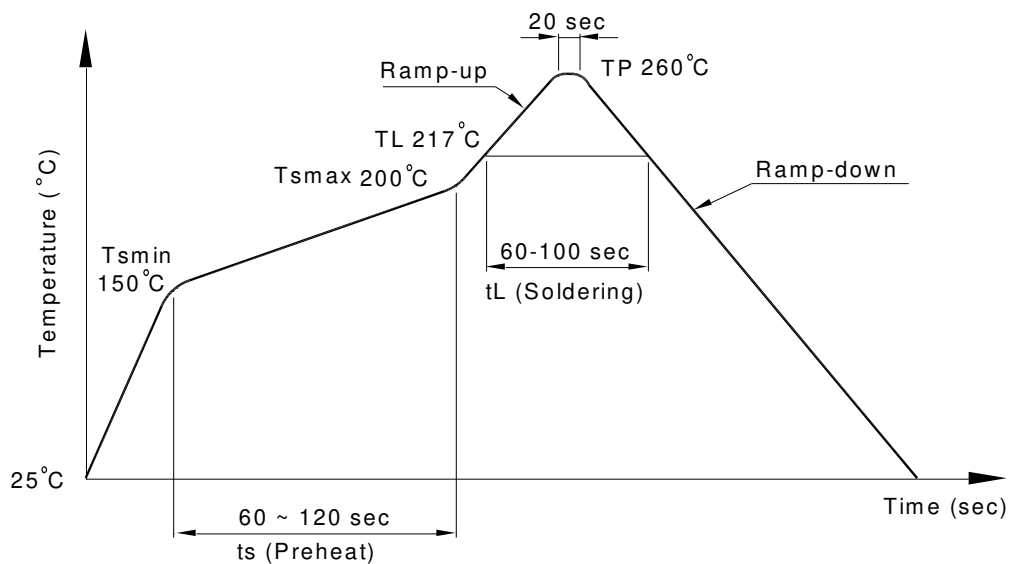

Photocouplers LTV-3150 series

8.2 Wave soldering (JEDEC22A111 compliant)

One time soldering is recommended within the condition of temperature.

Temperature: $260 \pm 0 / -5^{\circ}\text{C}$

Time: 10 sec.

Preheat temperature: 25 to 140°C

Preheat time: 30 to 80 sec.

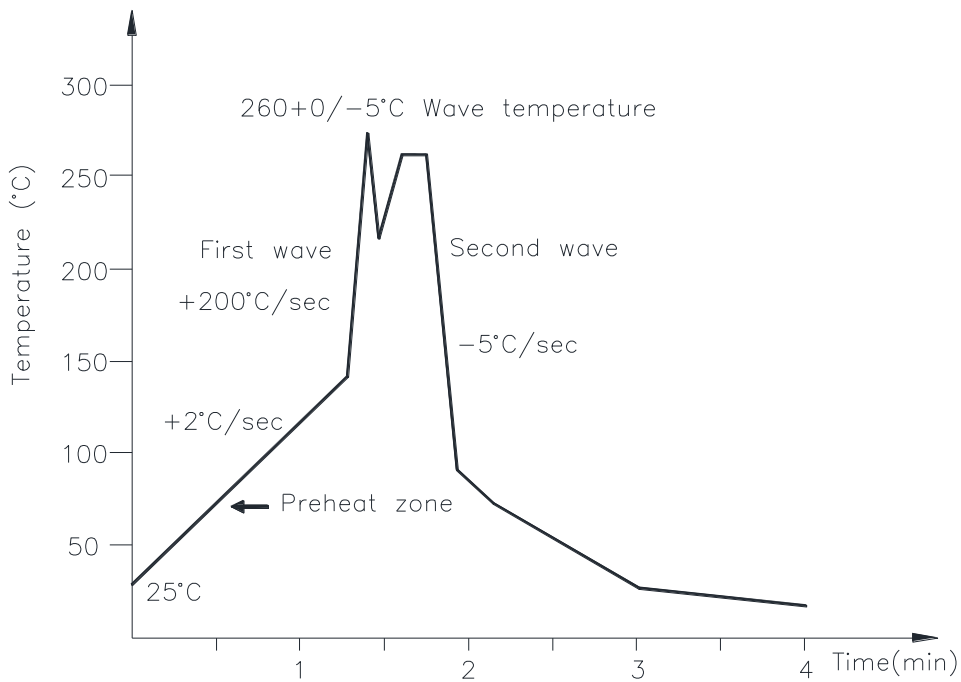

8.3 Hand soldering by soldering iron

Allow single lead soldering in every single process. One time soldering is recommended.

Temperature: $380 \pm 0 / -5^{\circ}\text{C}$

Time: 3 sec max.

**Photocouplers
LTV-3150 series**

9. ORDERING INFORMATION

Parameter	Option	Minimum CMR		Input-On Current (mA)	Remark
		dV/dt (V/μs)	V _{CM} (V)		
LTV-3150		15,000	1500	10	Single Channel, DIP-8
	M				Single Channel, Wide Lead Spacing
	S				Single Channel, SMD-8