

LOC	DIST	REVISIONS					
AF	50	P	LTR	DESCRIPTION	DATE	DWN	APVD
		F1		REVISED PER ECR-09-002564	12FEB09	HMR	KR

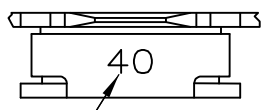

IDENTIFICATION NO. FOR MAGNET WIRE RANGE

- FOR MAG-MATE CAVITY SPECIFICATION REFER TO APPLICATION SPEC #114-2066.
- CONTINUOUS STRIP ON REELS WITH TERMINALS LOCATED ON 8.38 [.330] CENTERS.
- DIMENSIONS IN BRACKETS ARE IN INCHES.
- AFTER INSERTION INTO PLASTIC HOLDER TAB PORTION MUST BE BENT OVER 45° TO 90° OR POTTED-IN TO PREVENT PULL-OUT WHEN MATING RECEPTACLE IS DISCONNECTED.

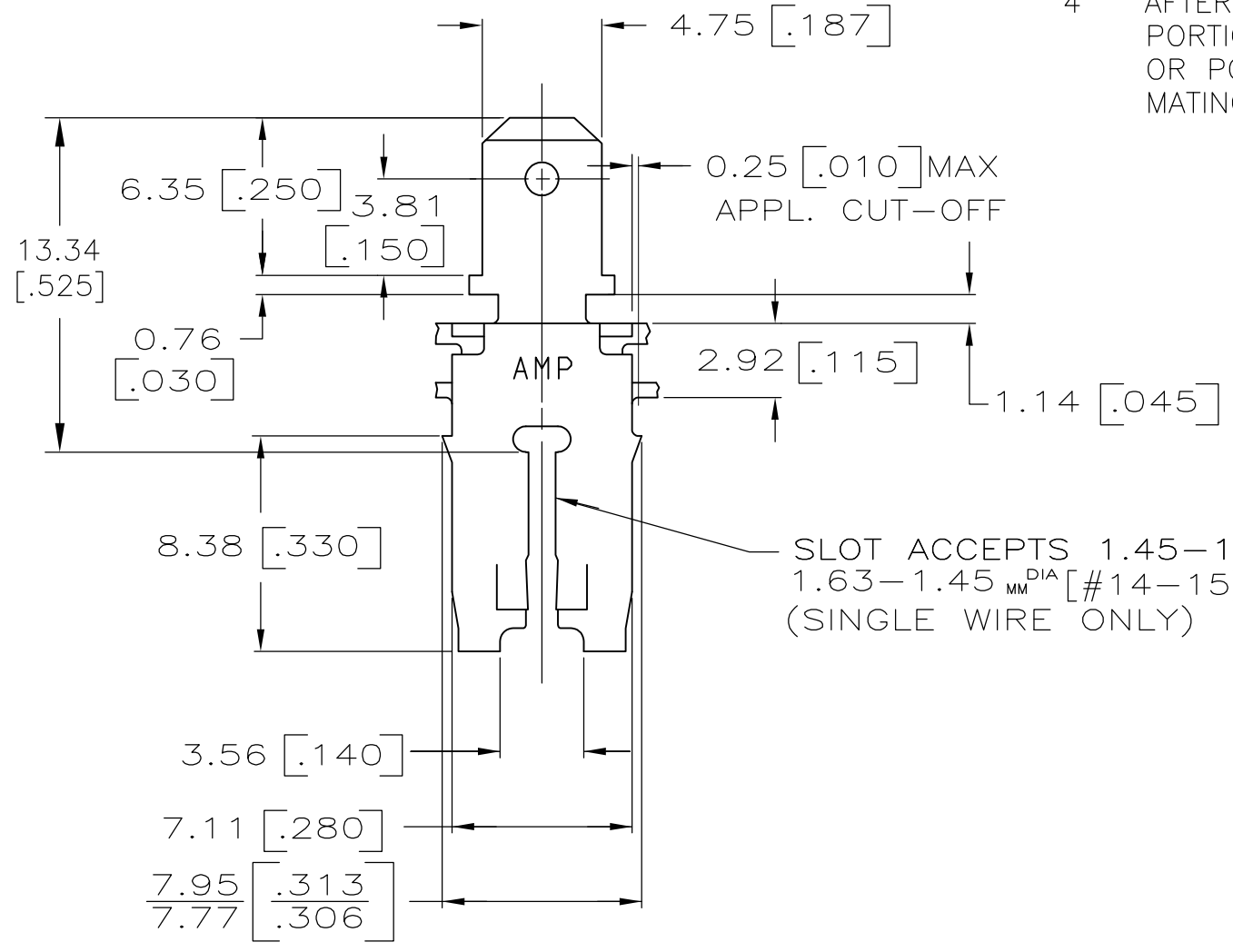
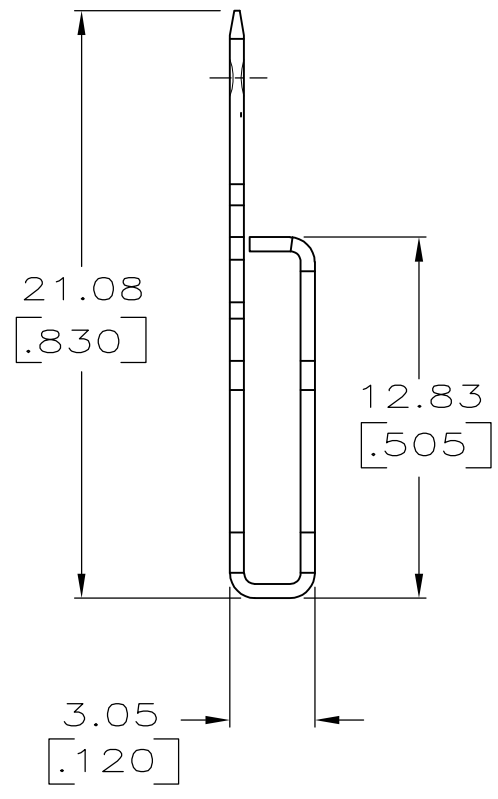

SLOT ACCEPTS 1.45-1.29^{DIA} MM [#15-16] COPPER OR 1.63-1.45^{DIA} MM [#14-15] ALUMINUM MAGNET WIRE. (SINGLE WIRE ONLY)

63353-1
PART NO

THIS DRAWING IS A CONTROLLED DOCUMENT.		DWN	JR RUTH	2/14/86	Tyco Electronics Corporation Harrisburg, PA 17105-3608
DIMENSIONS: mm [INCHES]		CHK	G YETTER	2/17/86	
TOLERANCES UNLESS OTHERWISE SPECIFIED:		APVD	J SWARTZ	2/18/86	
0 PLC ± - 1 PLC ± - 2 PLC ± - 3 PLC ± 0.38 [.015] 4 PLC ± - ANGLES ± -		PRODUCT SPEC	MAG-MATE .187 FASTON TAB		
MATERIAL	0.51 [.020] BRASS	FINISH	TIN	WEIGHT	-
CUSTOMER DRAWING				SIZE	A3
				CAGE CODE	00779
				DRAWING NO	C-63353
				RESTRICTED TO	-
				SCALE	4:1
				SHEET	1 OF 1
				REV	F1

