

## FEATURES

- Surface mount package
- Low capacitance
- Fast response
- High shunt impedance
- Tape & reel supplied

## PRODUCT DESCRIPTION

This planar silicon photodiode features a lensed, water clear epoxy package suitable for surface mount assembly in a "back mounted" (lens up) orientation.

These photodiodes exhibit performance characteristics which make them suitable for a wide range of near-IR sensing applications. Devices are shipped taped & reeled on a 24 mm embossed carrier.

## ELECTRO-OPTICAL CHARACTERISTICS @ 25° C

PARAMETER	SYMBOL	MIN.	TYP.	MAX.	UNITS
SHORT CIRCUIT CURRENT @ 100 fc, 2850 K	I <sub>SC</sub>	75	90		μA
DARK CURRENT @ V <sub>R</sub> = 10 V	I <sub>D</sub>			20	nA
SHUNT RESISTANCE @ H = 0, V = 10 mV	R <sub>SH</sub>		0.25		GΩ
JUNCTION CAPACITANCE @ V <sub>R</sub> = 3 V	C <sub>J</sub>			50	pF
OPEN CIRCUIT VOLTAGE @ 100 fc, 2850 K	V <sub>OC</sub>	325			mV
ANGULAR RESPONSE (50% RESPONSE POINT)	θ <sub>1/2</sub>		±42		Degrees

## PACKAGE DIMENSIONS inch (mm)

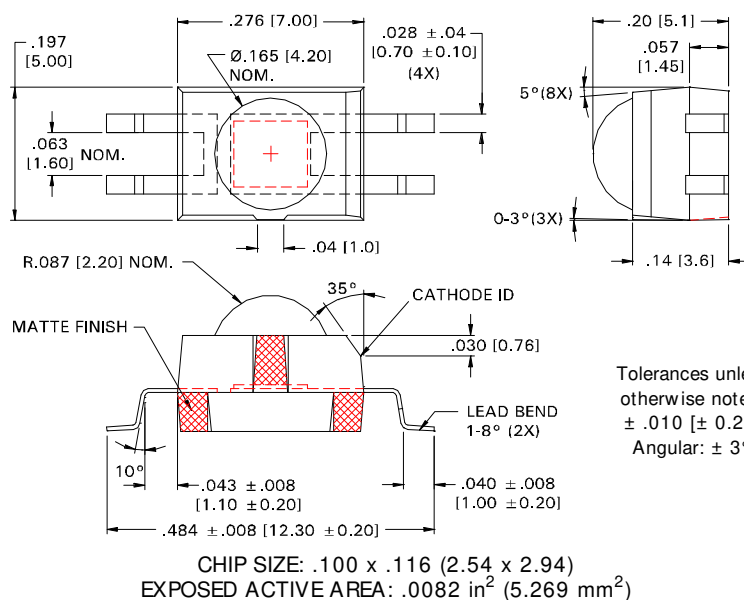

RoHS Compliant



## TYPICAL SPECTRAL RESPONSE

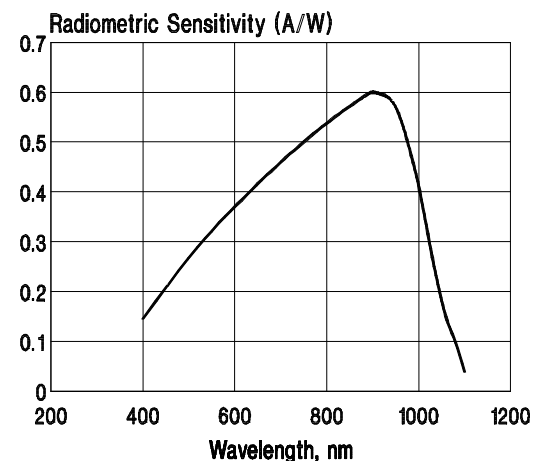

## GENERAL CHARACTERISTICS

PARAMETER	SYMBOL	TYPICAL RATING	UNITS
PEAK SPECTRAL RESPONSE @ 25°C	$\lambda_P$	925	nm
RADIOMETRIC SENSITIVITY @ PEAK, 25°C	S <sub>RPK</sub>	0.6	A / W
NOISE EQUIVALENT POWER	NEP	$2.0 \times 10^{-13}$	W/ $\sqrt{\text{Hz}}$
SPECIFIC DETECTIVITY	D*	$1.2 \times 10^{12}$	cm $\sqrt{\text{Hz}}$ / W
TEMPERATURE COEFFICIENT			
SHORT CIRCUIT CURRENT @ 2850 K SOURCE	TC I <sub>SC</sub>	+0.22	%/°C
OPEN CIRCUIT VOLTAGE @ 2850 K SOURCE	TC V <sub>OC</sub>	-2.0	mV/ C
DARK CURRENT	TC I <sub>D</sub>	+15.0	%/°C

## ABSOLUTE MAXIMUM RATINGS

PARAMETER	SYMBOL	RATING	UNITS
TEMPERATURE RANGE OPERATING AND STORAGE	T <sub>AMB</sub>	-40 to +85	°C
LEAD SOLDER TEMPERATURE (1.6 mm FROM CASE, 5 SECONDS MAX.)	T <sub>LS</sub>	260°	°C
BREAKDOWN VOLTAGE @ 25°C	V <sub>BR</sub>	33	Volts
POWER DISSIPATION	P <sub>D</sub>	150	mW

## TYPICAL CHARACTERISTIC CURVES

RELATIVE JUNCTION CAPACITANCE vs BIAS VOLTAGE  
(REFERRED TO ZERO BIAS)

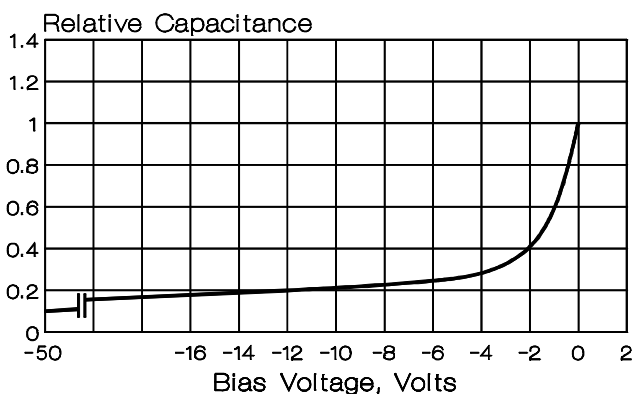

ANGULAR RESPONSE

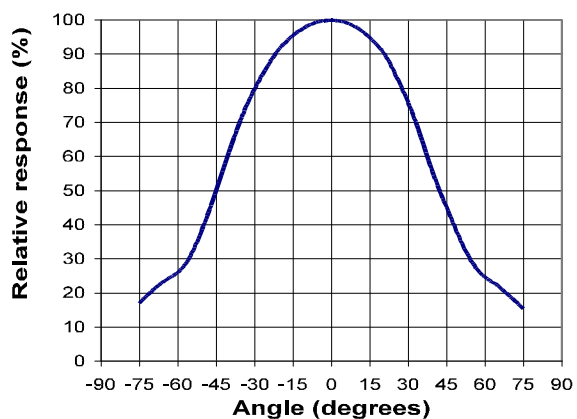

Specifications subject to change without prior notice. Information supplied by Excelitas Technologies is believed to be reliable, however, no responsibility is assumed for possible inaccuracies or omissions. The user should determine the suitability of this product in his own application. No patent rights are granted to any devices or circuits described herein.