

# Motor Contactor J7KN

## Main contactor

- AC & DC operated
- Integrated auxiliary contacts
- Screw fixing and snap fitting (35 mm DIN rail) up to 45 kW
- Range from 4 to 110 kW (AC 3, 380/415V)
- Finger proof ( VBG 4)

## Accessoires

- front mounted single pole additional auxiliary contacts (1 NO or 1 NC)
- Side mounted additional auxiliary contacts (1 NO/1 NC)
- Mechanical interlock
- Suppressors (RC and varistor)
- Pneumatic timer modules
- Link modules MPCB - Motor contactor



## Approved Standards

Standard	Guide No (US,C)
UL	NLDX, NLDX7
ICE 947-4-1	
VDE 0660	
EN 60947-4-1	



# Ordering Information

## ■ Model Number Legend

### 1. Motor Contactors

J7KN-□□□-□□-□□□□  
 1 2 3 4

- 1) Motor Contactor
- 2) Rated Motor Current (AC3 400V)
  - 10: 10A
  - 14: 14A
  - 18: 18A
  - 22: 22A
  - 24: 24A
  - 32: 32A
  - 40: 40A
  - 50: 50A
  - 62: 62A
  - 74: 74A
  - 85: 85A
  - 110: 110A
  - 150: 150A
  - 175: 175A
  - 200: 200A
- 3) Integrated auxiliary contact
  - 10: 1NO 0NC
  - 01: 0NO 1NC
  - 21: 2NO 1NC
  - 22: 2NO 2NC
  - : 0NO 0NC
- 4) Coil voltage ( AC operated )
  - 20: AC20V 50Hz, AC24V 60Hz
  - 24: AC24V 50/60Hz
  - 46: AC48V 50/60 Hz
  - 48: AC48V 50Hz, AC60V 60Hz
  - 48B: AC48V 50Hz
  - 90: AC100V 50/60Hz
  - 110: AC110V 50Hz, AC110-120V 60Hz
  - 180: AC180-210V 50Hz, AC200-240V 60Hz
  - 230: AC220-240V 50Hz, AC240V 60Hz
  - 400: AC380-415V 50Hz, AC415-440V 60Hz
  - 500: AC500-550V 50Hz, AC550-600V 60Hz

Coil voltage( DC operated )

- 24D: DC24V
- 48D: DC48V
- 110D: DC110V
- 125D: DC125V

### 2. Aux. Contact Modules for Motor Contactors

J73KN-□-□□-□□  
 1 2 3 4

- 1) Auxiliary Contact Modules
- 2) B: for motor contactor (4-37kW)  
C: for motor contactor (11-37kW)
- 3) Combination of NO/NC contacts
  - 10: 1NO 0NC
  - 01: 0NO 1NC
  - 11: 1NO 1NC
- 4) S: side mounting  
: front mounting

### 3. Accessories for Motor Contactors (Link Modules MPCB - Motor Contactor)

J74KN-□□-□□  
 1 2 3

- 1) Accessories for Motor Contactors
- 2) VD: Link module type  
HU: DIN-rail adapter type
- 3) 12: for motor contactor (4 - 7.5kW)  
25: for motor contactor (11 - 15kW)

### 4. Accessories for Motor Contactors (Pneumatic Timers)

J74KN-□-□□ □□ □□  
 1 2 3 4 5

- 1) Accessories for Motor Contactors
- 2) B: Motor Contactor (4-11kW)
- 3) TP: Pneumatic Timer
- 4) 40: 40 sec  
180: 180 sec
- 5) DA: ON-delayed  
IA: OFF-delayed

### 5. Accessories for Motor Contactors (Mechanical Interlock)

J74KN-□-□□  
 1 2 3

- 1) Accessories for Motor Contactors
- 2) B: Motor Contactor (4-18.5kW)  
C: Motor Contactor (22-37kW)  
D: Motor Contactor (45-55kW)
- 3) ML: Mechanical Interlock

### 6. Accessories for Motor Contactors (RC Suppressor units)

J74KN-□-□□ □□ □□  
 1 2 3 4

- 1) Accessories for Motor Contactors
- 2) A: for Mini Motor Contactor and Motor Contactor (4-18.5kW) (between DIN-rail and Contactor)  
B: for Mini Motor Contactor and Motor Contactor (4-55kW) (universal)
- 3) RC: RC-surge suppressors
- 4) 48: 24 - 48 VAC/DC  
230: 110 - 230 VAC/DC  
400: 250 - 415 VAC/DC

### 7. Accessories for Motor Contactors (Varistor units)

J74KN-□-□□ □□ □□  
 1 2 3 4







- 1) Accessories for Motor Contactors
- 2) A: for Motor Contactor (4-11kW) to snap on to coil terminals  
B: for Motor Contactor (4-37kW) to snap on to contactor
- 3) VG: Varistor Suppressors
- 4) 230: 110-230VAC/DC  
400: 250-415VAC/DC

## List of Models



### Contactors 3-pole

- Up to 210A AC3
- Up to 350A AC1
- DIN-rail mounting up to AC3 74A
- International Approvals
- Data according to IEC 947 / EN 60947







Ratings													
AC3	400V Motor	10A	14A	18A	22A	24A	32A	40A	50A	62A	74A		
	380-400V	4kW	5,5kW	7,5kW	11kW	11kW	15kW	18,5kW	22kW	30kW	37kW		
	660-690V	5,5kW	7,5kW	10kW	10kW	15kW	18,5kW	18,5kW	30kW	37kW	45kW		
AC1	690V at 40°C	25A	25A	32A	32A	50A	65A	80A	110A	120A	130A		
Type		J7KN-10-10	J7KN-14-10	J7KN-18-10	J7KN-22-10	J7KN-24	J7KN-32	J7KN-40	J7KN-50	J7KN-62	J7KN-74		
Auxiliary contacts		1NO	1NO	1NO	1NO	-	-	-	-	-	-		
Type		J7KN-10-01	J7KN-14-01	J7KN-18-01	J7KN-22-01	-	-	-	-	-	-		
Auxiliary contacts		1NC	1NC	1NC	1NC	-	-	-	-	-	-		
Cable cross-section													
Solid	mm <sup>2</sup>	0,75 - 6				1,5 - 25			4 - 50				
Flexible	mm <sup>2</sup>	1 - 4				2,5 - 16			10 - 35				
Cables per clamp		2				1 + 1			1 + 1				
Auxiliary contact													
I <sub>th</sub>	40°C	A 16				-			-				
AC15	230V	A 12				-			-				
	400V	A 4				-			-				
Power consumption of coils													
	Inrush VA	33 - 45				90 - 115			140 - 165				
	Hold VA	7 - 10				9 - 13			13 - 18				
	Operation range of coils	0,85 - 1,1				0,85 - 1,1			0,85 - 1,1				
Mounting		35mm DIN-rail or base											
Additional aux. contact blocks													
Front mounting contacts	Type	 J73KN-B-10 1NO f. low level switching				 J73KN-B-01 1NC f. low level switching				maximal 4 J73KN-B..			
Additional aux. contact blocks													
Side mounting contacts	Type	-	-	-	-	 J73KN-C-11S 1NO+1NC f. low level switching max. 2 J73KN-C-11S							
Overload Relay (thermal)													
Single phase protection Temperature compensation Trip and alarm contacts													
	Type	J7TKN-B		J7TKN-A		J7TKN-C		J7TKN-D					
	Setting Ranges	0,12 - 0,18A		1,8 - 2,7A		10 - 14A		20 - 28A					
		0,18 - 0,27A		2,7 - 4A		14 - 20A		28 - 42A					
		0,27 - 0,4A		4 - 6A		20 - 28A		40 - 52A					
		0,4 - 0,6A		6 - 9A		28 - 42A		52 - 65A					
		0,6 - 0,9A		8 - 11A				60 - 74A					
		0,8 - 1,2A		10 - 14A									
		1,2 - 1,8A		13 - 18A									
		17 - (23)24A		(22)23 - (30)32A									



Ratings						
AC3	400V Motor	85A	110A	150A	175A	210A
	380-400V	45kW	55kW	75kW	90kW	110kW
	660-690V	55kW	55kW	75kW	110kW	132kW
AC1	690V at 40°C	150A	170A	200A	250A	350A
Type		J7KN-85-22	J7KN-110-22	J7KN-150-11	J7KN-175-11	J7KN-200-22
Auxiliary contacts		2NO+2NC	2NO+2NC	1NO+1NC	1NO+1NC	2NO+2NC
Type		-	-	-	-	-
Auxiliary contacts		-	-	-	-	-
<b>Cable cross-section</b>						
Solid	mm <sup>2</sup>	10 - 70	10 - 70	busbar	busbar	busbar
Flexible	mm <sup>2</sup>	16 - 50	16 - 50	18x5	18x5	22x4
Cables per clamp		1	1	1	1	1
<b>Auxiliary contact</b>						
I <sub>th</sub>	40°C	A 16		10		
AC15	230V	A 12		3		
	400V	A 6		2		
<b>Power consumption of coils</b>						
	Inrush VA	350 - 420		550	550	1100
	hold VA	23 - 29		130	130	66
	Operation range of coils	0,85 - 1,1		0,85 - 1,1		
Mounting		base				
<b>Additional aux. contact blocks</b>						
Front mounting contacts	Type					
<b>Additional aux. contact blocks</b>						
Side mounting contacts	Type	-	-	-	-	-
<b>Overload Relay (thermal)</b>						
Single phase protection Temperature compensation Trip and alarm contacts						
	Type	J7TKN-E		J7TKN-F		
	Setting Ranges	60 - 90A		100 - 150A		
		80 - 120A		140 - 220A		
		<b>Busbar Sets</b>				
		J74TK-SU-175, J74TK-SU-200				

**Contactors 3-pole**  
**AC Operated**

	Ratings			Rated Current AC1 690V A	Aux. Contacts		Type	Pack	Weight				
	AC2, AC3				Built-in					Additional see page 28 Type			
	380V 400V 415V kW	500V kW	660V 690V kW		NO	NC							
	4	5.5	5.5	25	1	-	max. 4 J73KN-B	Coil Voltage <sup>1</sup> 24V 50/60Hz 110V 50Hz 220-240V 50Hz	pcs.	kg/pc.	J7KN-10-10□□□□	1	0.23
	4	5.5	5.5	25	-	1					J7KN-10-01□□□□	1	0.23
	5.5	7.5	7.5	25	1	-					J7KN-14-10□□□□	1	0.23
	5.5	7.5	7.5	25	-	1					J7KN-14-01□□□□	1	0.23
	7.5	10	10	32	1	-					J7KN-18-10□□□□	1	0.23
	7.5	10	10	32	-	1					J7KN-18-01□□□□	1	0.23
	11	10	10	32	1	-					J7KN-22-10□□□□	1	0.23
	11	10	10	32	-	1					J7KN-22-01□□□□	1	0.23
	11	15	15	50	-	-	max. 4 J73KN-B + 2 J73KN- C-11S	J7KN-24□□□□	1	0.48			
	15	18.5	18.5	65	-	-		J7KN-32□□□□	1	0.48			
	18.5	18.5	18.5	80	-	-		J7KN-40□□□□	1	0.48			
	22	30	30	110	-	-	max. 4 J73KN-B + 2 J73KN- C11S	J7KN-50□□□□	1	0.85			
	30	37	37	120	-	-		J7KN-62□□□□	1	0.85			
	37	45	45	130	-	-		J7KN-74□□□□	1	0.85			
	Ratings			Rated Current AC1 690V A	Aux. Contacts		Type	Pack	Weight				
	AC2, AC3				Built-in					Coil Voltage <sup>1</sup>			
	380V 415V kW	500V kW	660V 690V kW		NO	NC							
	45	55	55	150	2	2	220-230V 50Hz 380-400V 50Hz	J7KN-85-22□□□□	1	1.8			
	55	75	55	170	2	2		J7KN-110-22□□□□	1	1.9			
	75	75	75	200	1	1	J7KN-150-11□□□□	1	5				
	90	90	90	250	1	1	J7KN-175-11□□□□	1	5				
	110	132	132	350	2	2	J7KN-200-22□□□□	1	7.3				

\*1) Coil voltage range and other coil voltages see page 30

**Contactors 3-pole  
DC Operated**

Type	Coil voltage		Aux. Contacts			Weight kg/pc.	Accept Overload Relay page 52 Type	Busbar Set for Overload Relay page 53 Type	Wiring Diagram  Coil Circuits see page 41  Terminal Markings
	24 60 110 220	24V DC 60V DC 110V DC 220V DC	Built-in NO NC		Additional see page 28 *1 Type				
J7KN-10-10□□□□D			1	-	max. 3	0.25	J7TKN-B	-	
J7KN-10-01□□□□D			-	1	J73KN-B	0.25	J7TKN-A	-	
J7KN-14-10□□□□D			1	-		0.25		-	
J7KN-14-01□□□□D			-	1		0.25		-	
J7KN-18-10□□□□D			1	-		0.25		-	
J7KN-18-01□□□□D			-	1		0.25		-	
J7KN-22-10□□□□D			1	-		0.25		-	
J7KN-22-01□□□□D			-	1		0.25		-	
J7KN-24□□□□D			-	-	max. 3	0.55	J7TKN-B	-	
J7KN-32□□□□D			-	-	+ 2 J73KN- C-11S	0.55	J7TKN-C	-	
J7KN-40□□□□D			-	-		0.55		-	
J7KN-50□□□□D			-	-	max. 3	0.9	J7TKN-D	-	
J7KN-62□□□□D			-	-	+ 2 J73KN- C-11S	0.9		-	
J7KN-74□□□□D			2	1		1.6		-	
Type	Coil voltage		Aux. Contacts			Weight kg/pc.	Accept Overload Relay page 102 Type	Busbar Set for Overload Relay page 103 Type	-22 
	110 220	110V DC 220V DC	Built-in NO NC		Additional see page 28 *1 Type				
J7KN-85-21□□□□D			2	1	-	1.8	J7TKN-E		
J7KN-110-21□□□□D			2	1	-	1.9			
							J7TKN-F	J73TK-SU-175 J73TK-SU-200	

\*1) Only 3 additional Aux. Contacts are possible! (See also the wiring diagramms coil circuit DC operated page 29)

**Contactors 4-pole**  
**AC Operated**

	Ratings		Rated Current AC1 690V A	Aux. Contacts		Type	Pack pcs.	Weight kg/pc.
	AC2, AC3 380V 400V 415V kW	AC1 400V kW		Built-in	Additional see below Type			
	4	17.5	25	NO	NC	max. 4 J73KN-B	1	0.22
						Coil Voltage*1 24V 50/60Hz 110V 50Hz 220-240V 50Hz		

\*1) Coil voltage range and other coil voltages see page 30

**Auxiliary Contact Blocks** for contactors J7KN-10... to -74... type J73KN for low level switching\*1

Front mounting	Rated Operational Current			Contacts				Type	Pack pcs.	Weight kg/pc.
	AC15 230V A	AC15 400V A	AC1 690V A	NO	NC	EM	LB			
	3	2	10	1	-	-	-	J73KN-B-10	10	0.02
	3	2	10	-	1	-	-	J73KN-B-01	10	0.02

**Auxiliary Contact Blocks** for contactors J7KN-10... to -74... type J73KN for low level switching\*1

Side mounting	Rated Operational Current			Contacts	Type	Pack pcs.	Weight kg/pc.		
	AC15 230V A	AC15 400V A	AC1 690V A						
	3	2	10	NO	NC	10	0.02		
				for side mounting					
				max. 2	1	1	J73KN-C-11S	10	0.02

**Pneumatic Timer** for contactors J7KN-10... to -22...

	Function	Time range s	Contacts				Type	Pack pcs.	Weight kg/pc.
			NO	NC	NO	NC			
	On-delay	0.1 - 40	1	1	-	-	J74KN-B-TP40DA	1	0.09
	On-delay	10 - 180	1	1	-	-	J74KN-B-TP180DA	1	0.09
	Off-delay	0.1 - 40	-	-	1	1	J74KN-B-TP40IA	1	0.09
	Off-delay	10 - 180	-	-	1	1	J74KN-B-TP180IA	1	0.09



1. suitable according to DIN 19240 (test ratings 17V DC, 5mA) Technical data see page 45





**Mechanical Interlocks**

	Interlocks contactor with contactor		Mounting	Type	Pack pcs.	Weight kg/pc.
	Type	Type				
	J7KN10 - J7KN40	J7KN10 - J7KN40	horizontal	J74KN-B-ML	1	0.006
	J7KN24 - J7KN74	J7KN24 - J7KN74	horizontal	J74KN-C-ML	1	0.010
	J7KN85 - J7KN110	J7KN85 - J7KN110	horizontal	J74KN-D-ML	1	0.076

**Suppressor Units**

	Voltage Range V	Mounting	Type	Pack pcs.	Weight kg/pc.
		<b>Varistor</b> for contactors J7KN-10 to J7KN-22			
110 - 230V AC/DC		to snap on to coil terminals	J74KN-A-VG230	10	0.01
250 - 415V AC/DC		to snap on to coil terminals	J74KN-A-VG400	10	0.01
<b>Varistor</b> for contactors J7KN-10 to J7KN-74					
110 - 230V AC/DC		to snap on the contactor	J74KN-B-VG230	10	0.02
250 - 415V AC/DC		to snap on the contactor	J74KN-B-VG400	10	0.02
	<b>RC-unit</b> for contactors J7KN-10 to J7KN-40, J7KNA				
	110 - 230V AC/DC	between DIN-rail and contactor	J74KN-A-RC230	1	0.036
	<b>RC-units</b> for contactors J7KN-10 to J7KN-110				
	24 - 48V AC/DC	universal (fixing band, adhesive strip)	J74KN-B-RC48	5	0.02
	110 - 230V AC/DC	universal (fixing band, adhesive strip)	J74KN-B-RC230	5	0.02
	250 - 415V AC	universal (fixing band, adhesive strip)	J74KN-B-RC400	5	0.02

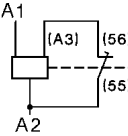
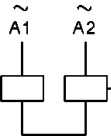
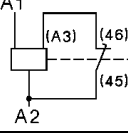
**■ Wiring Diagrams Coil Circuit**

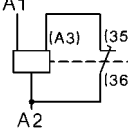
AC operated or with DC magnet system	DC operated with double winding coil*1
J7KN-10... to J7KN-175... 	J7KN-10...D to J7KN-22...D 
J7KN-200... 	J7KN-24...D to J7KN-74...D 
DC solenoid operated 	J7KN-85...D to J7KN-110...D 

\*1) Only 3 additional Aux. Contacts are possible! (See also the wiring diagramms coil circuit DC operated page 27)

# Specifications

## ■ Coil Voltages

Type-suffix for contactor types J7KN-10... to J7KN-74...

Suffix to contactor type e.g. <b>J7KN-10-10-24</b>	Voltage Marking at the coil		Rated Control Voltage U <sub>s</sub> range for			
	for 50Hz V	for 60Hz V	50Hz		60Hz	
			min V.	max V.	min V.	max V.
6	6		6	6.6	6.6	7.3
6.6	6.6		6.6	7.3	7.3	8
7.3	7.3		7.3	8	8	9
8	8		8	9	9	10
9	9		9	10	10	11
10	10		10	11	11	12
11	11	12	11	12	12	13.2
12	12		12	13.2	13.2	14.5
13.2	13.2		13.2	14.5	14.5	16
14.5	14.5		14.5	16	16	18
16	16		16	18	18	20
18	18		18	20	20	22
20	20		20	22	22	24
<b>24</b>	<b>24</b>	<b>24</b>	<b>22</b>	<b>24</b>	<b>24</b>	<b>27</b>
25	25		24	27	27	30
27	27	32	27	30	30	33
31	32	36	30	33	33	36
33	36	36	33	36	36	39
36	36		36	39	39	42
40	42	42	39	42	42	47
<b>42</b>	<b>42</b>	<b>48</b>	<b>42</b>	<b>47</b>	<b>47</b>	<b>52</b>
48	48		47	52	52	58
55	55	60	52	58	58	65
60	60		58	65	65	72
65	65		65	72	72	80
75	75		72	80	80	90
85	85		80	90	90	100
90	90		90	100	100	110
<b>110</b>	<b>110</b>	<b>110-120</b>	<b>100</b>	<b>110</b>	<b>110</b>	<b>122</b>
115	115	125	110	122	122	135
127	127		122	135	135	150
140	140		135	150	150	165
150	150		150	165	165	180
165	165	180-208	165	180	180	208
180	180-210	200-240	180	210	200	240
200	200-230 <sup>*1</sup>	220-240	200	230 <sup>*1</sup>	220	240
<b>230</b>	<b>220-240</b>	<b>240</b>	<b>220</b>	<b>240</b>	<b>240</b>	<b>264</b>
254	254	277	240	264	264	290
270	270		264	290	290	315
300	300		290	315	315	345
320	320		315	345	345	380
345	345-400 <sup>*1</sup>	380-440 <sup>*1</sup>	345	400 <sup>*1</sup>	380	440 <sup>*1</sup>
<b>400</b>	<b>380-415</b>	<b>415-440</b>	<b>380</b>	<b>415</b>	<b>415</b>	<b>460</b>
415	415-440	440-480	400	440	440	480
440	440-480	480-500	440	480	480	530
480	480-500		480	530	530	580
500	500-550	550-600	500	550	550	600

Standard voltages in bold type letter

\*1) Operating range of magnet-coils: 0,85 x U<sub>s</sub> (min. value of rated control voltage) up to 1,05 x U<sub>s</sub> (max. value of rated control voltage)

Type-suffix for contactor types J7KN-85... to J7KN-110...

Suffix to contactor type e.g. <b>J7KN-85-22-24</b>	Voltage Marking at the coil		Rated Control Voltage U <sub>s</sub> range for			
	for 50Hz V	for 60Hz V	50Hz		60Hz	
			min V.	max V.	min V.	max V.
6	6		6	6,6	7,2	7,9
6,6	6,6		6,6	7,3	7,9	8,8
7,3	7,3		7,3	8	8,8	9,6
8	8		8	9	9,6	10,8
9	9		9	10	10,8	12
10	10		10	11	12	13,2
11	11		11	12	13,2	14,4
12	12		12	13,2	14,4	15,8
13,2	13,2		13,2	14,5	15,8	17,4
14,5	14,5		14,5	16	17,4	19,2
16	16		16	18	19,2	21,6
18	18	24	18	20	21,6	24
<b>20</b>	<b>20</b>	<b>24</b>	<b>20</b>	<b>22</b>	<b>24</b>	<b>26</b>
22	22		22	24	26	29
<b>24</b>	<b>24</b>		<b>24</b>	<b>27</b>	<b>29</b>	<b>32</b>
27	27	32	27	30	32	36
32	32	36	30	33	36	40
33	36	42	33	36	40	43
36	36		36	39	43	47
39	42	48	39	42	47	50
<b>42</b>	<b>42</b>		<b>42</b>	<b>47</b>	<b>50</b>	<b>56</b>
48	48	60	47	52	56	62
55	55		52	58	62	70
60	60		58	65	70	78
65	65		65	72	78	86
75	75		72	80	86	96
85	85		80	90	96	108
90	90	110-120	90	100	108	120
100	100	125	100	110	120	132
<b>110</b>	<b>110-120</b>		<b>110</b>	<b>122</b>	<b>132</b>	<b>146</b>
127	127		122	135	146	162
140	140		135	150	162	180
150	150		150	165	180	198
165	165	200-208	165	180	198	208
180	180-200	208-240	180	200	208	240
200	200-230 <sup>*1</sup>	240-260	200	230 <sup>*1</sup>	240	264
<b>230</b>	<b>220-240</b>	<b>277</b>	<b>220</b>	<b>240</b>	<b>264</b>	<b>288</b>
254	254		240	264	288	317
270	270		264	290	317	348
300	300		290	315	348	380
320	320	380-415	315	345	380	415
345	345-400 <sup>*1</sup>	415-440	345	400 <sup>*1</sup>	415	455
<b>400</b>	<b>380-415</b>	<b>460-480</b>	<b>380</b>	<b>415</b>	<b>455</b>	<b>498</b>
415	415-440	480-500	400	440	480	528
440	440-480	550-575	440	480	528	575
480	480-500	575-600	480	530	575	630
500	500-550	600-660	500	550	600	660
24FR	24	24	20	24	24	28
110FR	110	110	92	110	110	132

Standard voltages in bold type letter

\*1) Operating range of magnet-coils: 0,85 x U<sub>s</sub> (min. value of rated control voltage) up to 1,05 x U<sub>s</sub> (max. value of rated control voltage)

Type-suffix for contactor types J7KN-150... to J7KN-200...

Suffix to contactor type e.g. <b>J7KN-150-110</b>	Voltage Marking at the coil		Rated Control Voltage $U_s$ range for			
	for 50Hz V	for 60Hz V	50Hz		60Hz	
			min V.	max V.	min V.	max V.
24	24		24	24	-	-
48	48		48	48	-	-
110	110	110	110	110	110	110
180	180	220	180	180	220	220
<b>230</b>	<b>220-230</b>	<b>220</b>	<b>220</b>	<b>230</b>	<b>220</b>	<b>220</b>
240	240	240	240	240	240	240
<b>400</b>	<b>380-400</b>		<b>380</b>	<b>400</b>	-	-
440		440	-	-	440	440

Standard voltages in bold type letter

## ■ Engineering data and characteristics

### Approximate Values for three-phase Motors

#### Motor Full Load Currents

Approximate values of motor F.L.C. and minimum „slow blow“ respectively „gL“ short-circuit fuse

Motor rating					220-230V Motor			240V Motor			380-400V Motor			415V Motor			500V Motor			660-690V Motor		
Range according to BS for 415V					Value of fusing at motor start			Value of fusing at motor start			Value of fusing at motor start			Value of fusing at motor start			Value of fusing at motor start			Value of fusing at motor start		
kW	PS-hp	hp	cosφ	%	F.L.C. A	D.O.L. A	YD A	F.L.C. A	D.O.L. A	YD A	F.L.C. A	D.O.L. A	YD A	F.L.C. A	D.O.L. A	YD A	F.L.C. A	D.O.L. A	YD A	F.L.C. A	D.O.L. A	YD A
0.06	0.08	-	0.7	59	0.38	1	1	0.35	1	1	0.22	1	1	-	-	-	0.16	1	1	-	-	-
0.09	0.12	-	0.7	60	0.55	2	2	0.5	2	2	0.33	1	1	-	-	-	0.24	1	1	-	-	-
0.12	0.16	-	0.7	61	0.76	2	2	0.68	2	2	0.42	2	2	-	-	-	0.33	1	1	-	-	-
0.18	0.24	-	0.7	61	1.1	2	2	1	2	2	0.64	2	2	-	-	-	0.46	1	1	-	-	-
0.25	0.34	-	0.7	62	1.4	4	2	1.38	4	2	0.88	2	2	-	-	-	0.59	2	2	-	-	-
0.37	0.5	-	0.72	64	2.1	4	4	1.93	4	4	1.22	4	2	-	-	-	0.85	2	2	0.7	2	2
0.55	0.75	-	0.75	69	2.7	4	4	2.3	4	4	1.5	4	2	-	-	-	1.2	4	2	0.9	2	2
0.75	1	1	0.8	74	3.3	6	4	3.1	6	4	2	4	4	2	4	4	1.48	4	2	1.1	2	2
1.1	1.5	1.5	0.83	77	4.9	10	6	4.1	6	6	2.6	4	4	2.5	4	4	2.1	4	4	1.5	4	2
1.5	2	2	0.83	78	6.2	10	10	5.6	10	10	3.5	6	4	3.5	6	4	2.6	4	4	2	4	4
2.2	3	3	0.83	81	8.7	16	10	7.9	16	10	5	10	6	5	10	6	3.8	6	6	2.9	6	4
2.5	3.4	-	0.83	81	9.8	16	16	8.9	16	10	5.7	10	10	-	-	-	4.3	6	6	-	-	-
3	4	4	0.84	81	11.6	20	16	10.6	20	16	6.6	16	10	6.5	16	10	5.1	10	10	3.5	6	4
3.7	5	5	0.84	82	14.2	25	20	13	25	16	8.2	16	10	7.5	16	10	6.2	16	10	-	-	-
4	5.5	-	0.84	82	15.3	25	20	14	25	20	8.5	16	10	-	-	-	6.5	16	10	4.9	10	6
5.5	7.5	7.5	0.85	83	20.6	35	25	18.9	35	25	11.5	20	16	11	20	16	8.9	16	10	6.7	16	10
7.5	10	10	0.86	85	27.4	35	35	24.8	35	35	15.5	25	20	14	25	16	11.9	20	16	9	16	10
8	11	-	0.86	85	28.8	50	35	26.4	35	35	16.7	25	20	-	-	-	12.7	20	16	-	-	-
11	15	15	0.86	87	39.2	63	50	35.3	50	50	22	35	25	21	35	25	16.7	25	20	13	25	16
12.5	17	-	0.86	87	43.8	63	50	40.2	63	50	25	35	35	-	-	-	19	35	25	-	-	-
15	20	20	0.86	87	52.6	80	63	48.2	80	63	30	50	35	28	35	35	22.5	35	25	17.5	25	20
18.5	25	25	0.86	88	64.9	100	80	58.7	80	63	37	63	50	35	50	50	28.5	50	35	21	35	25
20	27	-	0.86	88	69.3	100	80	63.4	80	80	40	63	50	-	-	-	30.6	50	35	-	-	-
22	30	30	0.87	89	75.2	100	80	68	100	80	44	63	50	40	63	50	33	50	50	25	35	35
25	34	-	0.87	89	84.4	125	100	77.2	100	100	50	80	63	-	-	-	38	63	50	-	-	-
30	40	40	0.87	90	101	125	125	92.7	125	100	60	80	63	55	80	63	44	63	50	33	50	35
37	50	50	0.87	90	124	160	160	114	160	125	72	100	80	66	100	80	54	80	63	42	63	50
40	54	-	0.87	90	134	160	160	123	160	160	79	100	100	-	-	-	60	80	63	-	-	-
45	60	60	0.88	91	150	200	160	136	200	160	85	125	100	80	100	100	64.5	100	80	49	63	63
51	70	-	0.88	91	168	200	200	154	200	200	97	125	100	-	-	-	73.7	100	80	-	-	-
55	75	-	0.88	91	181	250	200	166	200	200	105	160	125	-	-	-	79	125	100	60	80	63
59	80	80	0.88	91	194	250	250	178	250	200	112	160	125	105	160	125	85.3	125	100	-	-	-
75	100	100	0.88	91	245	315	250	226	315	250	140	200	160	135	200	160	106	160	125	82	125	100
90	125	125	0.88	92	292	400	315	268	315	315	170	250	200	165	200	200	128	160	160	98	125	125
110	150	150	0.88	92	358	500	400	327	400	400	205	250	250	200	250	250	156	200	200	118	160	125
129	175	175	0.88	92	420	500	500	384	500	400	242	315	250	230	315	250	184	250	200	-	-	-
132	180	-	0.88	92	425	500	500	393	500	500	245	315	250	-	-	-	186	250	200	140	200	160
147	200	200	0.88	93	472	630	630	432	630	500	273	315	315	260	315	315	207	250	250	-	-	-
160	220	-	0.88	93	502	630	630	471	630	630	295	400	315	-	-	-	220	315	250	170	200	200
184	250	250	0.88	93	590	800	630	541	630	630	340	400	400	325	400	400	259	315	315	-	-	-
200	270	-	0.88	93	626	800	800	589	800	630	370	500	400	-	-	-	278	315	315	215	250	250
220	300	300	0.88	93	700	1000	800	647	800	800	408	500	500	385	500	400	310	400	400	-	-	-
250	340	-	0.88	93	803	1000	1000	736	1000	800	460	630	500	-	-	-	353	500	400	268	315	315
257	350	350	0.88	93	826	1000	1000	756	1000	800	475	630	630	450	630	500	363	500	400	-	-	-
295	400	400	0.88	93	948	1250	1000	868	1000	1000	546	800	630	500	630	630	416	500	500	-	-	-
315	430	-	0.88	93	990	1250	1250	927	1250	1000	580	800	630	-	-	-	445	630	500	337	400	400
355	483	-	0.89	95	-	-	-	-	-	-	636	800	800	-	-	-	483	630	630	366	500	400
400	545	-	0.89	96	-	-	-	-	-	-	710	1000	800	-	-	-	538	630	630	410	500	500

The motor F.L.C. be valid for standard internal and surface cooled three-pole motors with 1500 min-. The fuses values be valid for the motor F.L.C. shown in the table and D.O.L.-start: starting current max. 6x motor F.L.C., starting time max. 5s; star-delta-start: starting current max. 2x motor F.L.C., starting time max. 15s. For motors with higher F.L.C., higher starting current and / or longer starting time, larger short-circuit fuses are required.

The maximum admissible value is dependent on the switchgear respectively thermal overload relay.

Approximate values of motor F.L.C. according to CSA and UL

Motor rating hp	Motor F.L.C. at 110-120V			Motor F.L.C. at 220-240V*1			Motor F.L.C. at 440-480V			Motor F.L.C. at 550-600V		
	1-phase A	2-phase A	3-phase A	1-phase A	2-phase A	3-phase A	1-phase A	2-phase A	3-phase A	1-phase A	2-phase A	3-phase A
½	9.8	4.0	4.4	4.9	2.0	2.2	2.5	1.0	1.1	2.0	0.8	0.9
¾	13.8	4.8	6.4	6.9	2.4	3.2	3.5	1.2	1.6	2.8	1.0	1.3
1	16.0	6.4	8.4	8.0	3.2	4.2	4.0	1.6	2.1	3.2	1.3	1.7
1½	20.0	9.0	12.0	10.0	4.5	6.0	5.0	2.3	3.0	4.0	1.8	2.4
2	24.0	11.8	13.6	12.0	5.9	6.8	6.0	3.0	3.4	4.8	2.4	2.7
3	34.0	16.6	19.2	17.0	8.3	9.6	8.5	4.2	4.8	6.8	3.3	3.9
5	56.0	26.4	30.4	28.0	13.2	15.2	14.0	6.6	7.6	11.2	5.3	6.1
7½	80.0	38.0	44.0	40.0	19.0	22.0	21.0	9.0	11.0	16.0	8.0	9.0
10	100.0	48.0	56.0	50.0	24.0	28.0	26.0	12.0	14.0	20.0	10.0	11.0
15	135.0	72.0	84.0	68.0	36.0	42.0	34.0	18.0	21.0	27.0	14.0	17.0
20	-	94.0	108.0	88.0	47.0	54.0	44.0	23.0	27.0	35.0	19.0	22.0
25	-	118.0	136.0	110.0	59.0	68.0	55.0	29.0	34.0	44.0	24.0	27.0
30	-	138.0	160.0	136.0	69.0	80.0	68.0	35.0	40.0	54.0	28.0	32.0
40	-	180.0	208.0	176.0	90.0	104.0	88.0	45.0	52.0	70.0	36.0	41.0
50	-	226.0	260.0	216.0	113.0	130.0	108.0	56.0	65.0	86.0	45.0	52.0
60	-	-	-	-	133.0	145.0	-	67.0	77.0	-	53.0	62.0
75	-	-	-	-	166.0	192.0	-	83.0	96.0	-	66.0	77.0
100	-	-	-	-	218.0	248.0	-	109.0	124.0	-	87.0	99.0
125	-	-	-	-	-	312.0	-	135.0	156.0	-	108.0	125.0
150	-	-	-	-	-	360.0	-	156.0	180.0	-	125.0	144.0
200	-	-	-	-	-	480.0	-	208.0	240.0	-	167.0	192.0
250	-	-	-	-	-	602.0	-	-	302.0	-	-	242.0
300	-	-	-	-	-	-	-	-	361.0	-	-	289.0
350	-	-	-	-	-	-	-	-	414.0	-	-	336.0
400	-	-	-	-	-	-	-	-	477.0	-	-	382.0
500	-	-	-	-	-	-	-	-	590.0	-	-	472.0

\*1) Determine the motor current for 200V and 208V by increasing the values for 220-240V at 200V about 15% and for 208V about 10%.

**Contactors**

**Data according to IEC 947-4-1, EN 60947-4-1, VDE 0660**

Main Contacts	Type	J7KN-10	J7KN-14	J7KN-18	J7KN-22	J7KN-24	J7KN-32	J7KN-40	J7KN-50	J7KN-62	J7KN-74
Rated insulation voltage $U_i^{11}$	V AC	690	690	690	690	690	690	690	690	690	690
Making capacity $I_m$	at $U_c = 690V$ AC A	200	200	200	200	400	500	500	700	900	900
Breaking capacity $I_{br}$	400V AC A	180	180	200	200	380	400	400	600	800	800
	J7KN-10 to J7KN-22 $\cos\phi = 0,65$	150	150	180	180	300	370	370	500	700	700
	J7KN-24 to J7KN-72 $\cos\phi = 0,35$	100	100	150	150	260	340	340	400	500	500
	1000V AC A	-	-	-	-	-	-	-	-	-	-
<b>Utilization category AC1</b>											
<b>Switching of resistive load</b>											
Rated operational current $I_c (=I_{rn})$ at 40°C, open	A	25	25	32	32	50	65	80	110	120	130
Rated operational power of three-phase resistive loads 50-60Hz, $\cos\phi = 1$	220V kW	9,5	9,5	12,2	12,2	19,0	24,7	30,4	41,9	45,7	49,5
	230V kW	9,9	9,9	12,7	12,7	19,9	25,9	31,8	43,8	47,7	51,7
	240V kW	10,4	10,4	13,3	13,3	20,8	27,0	33,2	45,7	49,8	54,0
	380V kW	16,4	16,4	21,0	21,0	32,9	42,7	52,6	72,3	78,9	85,5
	400V kW	17,3	17,3	22,1	22,1	34,6	45,0	55,4	76,1	83,0	90,0
	415V kW	17,9	17,9	23,0	23,0	35,9	46,7	57,4	79,0	86,2	93,3
	440V kW	19,0	19,0	24,4	24,4	38,1	49,5	60,9	83,7	91,3	99,0
	500V kW	21,6	21,6	27,7	27,7	43,3	56,2	69,2	95,2	103,8	112,5
	660V kW	28,5	28,5	36,5	36,5	57,1	74,2	91,3	125,6	137,0	148,4
	690V kW	29,8	29,8	38,2	38,2	59,7	77,6	95,5	131,3	143,2	155,2
1000V kW	-	-	-	-	-	-	-	-	-	-	
Rated operational current $I_c (=I_{rn})$ at 60°C, enclosed	A	25	25	32	32	40	55	65	90	100	110
Rated operational power of three-phase resistive loads 50-60Hz, $\cos\phi = 1$	220V kW	9,5	9,5	12,2	12,2	15,2	20,9	24,7	34,3	38,1	41,9
	230V kW	9,9	9,9	12,7	12,7	15,9	21,9	25,9	35,8	39,8	43,8
	240V kW	10,4	10,4	13,3	13,3	16,6	22,8	27,0	37,4	41,5	45,7
	380V kW	16,4	16,4	21,0	21,0	26,3	36,2	42,7	59,2	65,7	72,3
	400V kW	17,3	17,3	22,1	22,1	27,7	38,1	45,0	62,3	69,2	76,1
	415V kW	17,9	17,9	23,0	23,0	28,7	39,5	46,7	64,6	71,8	79,0
	440V kW	19,0	19,0	24,4	24,4	30,4	41,9	49,5	68,5	76,1	83,7
	500V kW	21,6	21,6	27,7	27,7	34,6	47,6	56,2	77,9	86,5	95,2
	660V kW	28,5	28,5	36,5	36,5	45,7	62,8	74,2	102,8	114,2	125,6
	690V kW	29,8	29,8	38,2	38,2	47,7	65,7	77,6	107,4	119,4	131,3
1000V kW	-	-	-	-	-	-	-	-	-	-	
Minimum cross-section of conductor at load with $I_c (=I_{rn})$	mm <sup>2</sup>	4	4	6	6	10	16	25	35	50	50
<b>Utilization category AC2 and AC3</b>											
<b>Switching of three-phase motors</b>											
Rated operational current $I_c$ open and enclosed	220V A	12	15	18	22	24	30	40	50	63	74
	230V A	11,5	14,5	18	22	24	30	40	50	62	74
	240V A	11	14	18	22	24	32	40	50	62	74
	<b>380-400V A</b>	<b>10</b>	<b>14</b>	<b>18</b>	<b>22</b>	<b>24</b>	<b>32</b>	<b>40</b>	<b>50</b>	<b>62</b>	<b>74</b>
	415V A	9	14	18	22	23	30	40	50	62	74
	440V A	9	14	18	22	23	30	40	50	62	74
	500V A	7	9	9	9	17,5	21	21	33	42	42
	660-690V A	6,5	8,5	8,5	8,5	17	20	20	31	40	40
	1000V A	-	-	-	-	-	-	-	-	-	-
	Rated operational power of three-phase motors 50-60Hz	220-230V kW	3	4	5	6	6	8,5	11	12,5	18,5
240V kW		3	4	5	7	7	9	11,5	13,5	19	23
<b>380-400V kW</b>		<b>4</b>	<b>5,5</b>	<b>7,5</b>	<b>11</b>	<b>11</b>	<b>15</b>	<b>18,5</b>	<b>22</b>	<b>30</b>	<b>37</b>
415V kW		4,5	6	8,5	12	12	16	20	24	33	40
440V kW		4,5	6	8,5	12	12	16	20	24	33	40
500V kW		5,5	7,5	10	10	15	18,5	18,5	30	37	45
660-690V kW		5,5	7,5	10	10	15	18,5	18,5	30	37	45
1000V kW	-	-	-	-	-	-	-	-	-	-	
<b>Utilization category AC4</b>											
<b>Switching of squirrel cage motors, inching</b>											
Rated operational current $I_c (=I_{rn})$ open and enclosed	220V A	12	15	18	18	24	30	40	50	63	63
	230V A	11,5	14,5	18	18	24	30	40	50	62	62
	240V A	11	14	18	18	24	32	40	50	62	62
	<b>380-400V A</b>	<b>10</b>	<b>14</b>	<b>18</b>	<b>18</b>	<b>24</b>	<b>32</b>	<b>40</b>	<b>50</b>	<b>62</b>	<b>62</b>
	415V A	9	14	18	18	23	30	37	45	60	60
	440V A	9	14	18	18	23	30	37	45	55	55
	500V A	9	12	16	16	17,5	21	21	33	42	42
	660V A	7	9	9	9	17	20	20	31	40	40
	690V A	6,5	8,5	8,5	8,5	17	20	20	31	40	40
	1000V A	-	-	-	-	-	-	-	-	-	-

Main Contacts		Type	J7KN-10	J7KN-14	J7KN-18	J7KN-22	J7KN-24	J7KN-32	J7KN-40	J7KN-50	J7KN-62	J7KN-74
Rated operational power of three-phase motors 50-60Hz	220-230V	kW	3	4	5	5	6	8,5	11	12,5	18,5	18,5
	240V	kW	3	4	5	5	7	9	11,5	13,5	19	19
	<b>380-400V</b>	<b>kW</b>	<b>4</b>	<b>5,5</b>	<b>7,5</b>	<b>7,5</b>	<b>11</b>	<b>15</b>	<b>18,5</b>	<b>22</b>	<b>30</b>	<b>30</b>
	415V	kW	4,5	6	8,5	8,5	12	16	20	24	33	33
	440V	kW	4,5	6	8,5	8,5	12	16	20	24	33	33
	500V	kW	5,5	7,5	10	10	15	18,5	18,5	30	37	37
	660-690V	kW	5,5	7,5	10	10	15	18,5	18,5	30	37	37
1000V	kW	-	-	-	-	-	-	-	-	-	-	
<b>Utilization category AC 5a</b>												
<b>Switching of gas discharge lamps</b>												
Rated operational current I <sub>n</sub> per pole at 220/230V												
Fluorescent lamps,												
uncompensated and serial compensated	A	20	20	25	25	40	52	64	88	96	104	104
parallel compensated	A	7	9	9	9	18	22	22	30	40	45	45
dual-connection	A	22,5	22,5	28	28	45	58	72	98	108	117	117
Metal halide lamps <sup>2</sup> ,												
uncompensated	A	12	15	19	19	30	39	48	66	72	78	78
parallel compensated	A	7	9	9	9	18	22	22	30	40	45	45
Mercury-vapour lamps <sup>3</sup> ,												
uncompensated	A	22,5	25	28	28	45	58	72	99	108	117	117
parallel compensated	A	7	9	9	9	18	22	22	30	40	45	45
Mixed light lamps <sup>4</sup>	A	20	20	25	25	40	52	64	88	96	104	104
<b>Utilization category AC5b</b>												
<b>Switching of incandescent lamps<sup>5</sup></b>												
Rated operational current I <sub>n</sub> per pole at 220/230V	A	12,5	12,5	12,5	12,5	25	31	31	43	56	56	56
<b>Utilization category AC6a</b>												
<b>Transformer primary switching</b>												
at inrush	n	30	30	30	30	30	30	30	30	30	30	30
Rated operational current I <sub>0</sub>	400V A	4,5	5,5	7,5	7,5	10,5	13,5	13,5	20	27	33	33
Rated operational power dependent on inrush n												
220-230V	kVA	1,8	2,2	3	3	4,2	5,4	5,4	8	10,7	13	13
240V	kVA	1,9	2,3	3,1	3,1	4,3	5,6	5,6	8,3	11,2	13,5	13,5
380-400V	kVA	3,1	3,8	5,2	5,2	7,3	9,3	9,3	13,5	18,5	22,5	22,5
For different inrush-factors x use the following formula: P <sub>x</sub> =P <sub>n</sub> *(n/x)												
415-440V	kVA	3,4	4,2	5,7	5,7	8	10,2	10,2	15	20,5	25	25
500V	kVA	3,9	4,8	6,5	6,5	9	11,5	11,5	17	23	28	28
660-690V	kVA	5,4	6,5	9	9	12,5	16	16	24	32	39	39
<b>Utilization category AC6b</b>												
<b>Switching of three-phase capacitor banks</b>												
Maximum inrush current (peak value) as multiple k of the capacitor rated current	k	35	25	20	20	25	25	25	25	25	25	20
Rated operational current I <sub>0</sub>	500V A	8	12	15,5	15,5	23	32	32	45	60	70	70
Rated operational power (sinφ→1)												
220-230V	kVAr	3	4,5	6	6	8,5	12	12	17	24	28	28
240V	kVAr	3,5	5	6,5	6,5	9,5	13	13	18,5	25	29	29
380-400V	kVAr	5	7,5	10	10	15	20	20	29	39	46	46
For different multiples x use the following formula: P <sub>x</sub> =P <sub>k</sub> *(k/x)												
415-440V	kVAr	5,5	8	11	11	16	22	22	32	43	50	50
500V	kVAr	7	10	13	13	20	26	26	39	50	58	58
660-690V	kVAr	7	10	13	13	20	26	26	40	50	58	58
<b>Switching of detuned capacitors</b>												
Rated operational current I <sub>0</sub>	690V A	8	13	18	20	28	36	42	48	72	105 <sup>1)</sup>	105 <sup>1)</sup>
Rated operational power												
220-230V	kVAr	2,9	5	7	7,5	11	14	16	20	28	33	33
240V	kVAr	3,1	5,4	7	8	11	14	17	20	28	36	36
380-400V	kVAr	5	9	12,5	13	20	25	27,5	33,3	50	75 <sup>1)</sup>	75 <sup>1)</sup>
415-440V	kVAr	5,5	9,5	13	14	22	27	30	36	53	75 <sup>1)</sup>	75 <sup>1)</sup>
500V	kVAr	6	11	15	17	25	30	36	40	60	75	75
660-690V	kVAr	8	15	20	22	33	41	48	55	82	100	100
<b>Utilization category DC1</b>												
<b>Switching of resistive load</b>												
Time constant L/R ≤1ms												
Rated operational current I <sub>0</sub>												
1 pole	24V A	20	25	32	32	50	65	80	110	120	130	130
	60V A	20	25	32	32	50	65	80	110	120	130	130
	110V A	6	6	6	6	10	10	10	12	12	12	12
	220V A	0,8	0,8	0,8	0,8	1,4	1,4	1,4	1,4	1,4	1,4	1,4
3 poles in series	24V A	20	25	32	32	50	65	80	110	120	130	130
	60V A	20	25	32	32	50	65	80	110	120	130	130
	110V A	20	25	32	32	50	65	80	110	120	130	130
	220V A	16	20	20	20	30	35	35	63	80	80	80

Main Contacts		Type	J7KN-10	J7KN-14	J7KN-18	J7KN-22	J7KN-24	J7KN-32	J7KN-40	J7KN-50	J7KN-62	J7KN-74	
<b>Utilization category DC3 and DC5</b>													
<b>Switching of shunt motors and series motors</b>													
Time constant L/R ≤15ms													
Rated operational current I <sub>o</sub>	1 pole/24V A	20	25	32	32	50	65	80	110	120	130		
		60V A	6	6	6	6	30	30	30	60	60	60	
		110V A	1,2	1,2	1,2	1,2	1,8	1,8	1,8	1,8	1,8	1,8	
	3 poles in series 24V A	220V A	0,2	0,2	0,2	0,2	0,2	0,2	0,2	0,25	0,25	0,25	
		20	25	32	32	50	65	80	110	120	130		
		60V A	20	25	32	32	40	40	40	80	80	80	
		110V A	20	20	20	20	40	40	40	80	80	80	
220V A	2,5	2,5	2,5	2,5	4	4	4	5	5	5			
<b>Maximum ambient temperature</b>													
Operation	open °C	-40 to +60 (+90) <sup>6</sup>											
	enclosed °C	-40 to +40											
with thermal overload relay	open °C	-25 to +60											
	enclosed °C	-25 to +40											
Storage	°C	-50 to +90											
<b>Short circuit protection</b>													
for contactors without thermal overload relay													
Coordination-type "1" according to IEC 947-4-1													
Contact welding without hazard of persons													
max. fuse size	gL (gG) A	63	63	63	63	80	80	80	160	160	160		
Coordination-type "2" according to IEC 947-4-1													
Light contact welding accepted													
max. fuse size	gL (gG) A	25	35	35	35	50	50	50	100	125	125		
Contact welding not accepted													
max. fuse size	gL (gG) A	16	16	16	16	25	35	35	50	63	63		
For contactors with thermal overload relay the device with the smaller admissible backup fuse (contactor or thermal overload relay) determines the fuse size.													
<b>Cable cross-sections</b>													
for contactors without thermal overload relay													
main connector	solid or stranded mm <sup>2</sup>	0,75 - 6					1,5 - 25			4 - 50			
	flexible mm <sup>2</sup>	1 - 4					2,5 - 16			10 - 35			
	flexible with multicore cable end mm <sup>2</sup>	0,75 - 4					1,5 - 16			6 - 35			
Cables per clamp		2					1			1			
	solid or stranded mm <sup>2</sup>	6+(1-6) / 4+(0,75-4)					16+(2,5-6) / 10+(4-10)			50+4 / 35+6 / 25+(6-16)			
	flexible mm <sup>2</sup>	2,5+(0,75-2,5) / 1,5+(0,75-1,5)					6+(4-6) / 4+(2,5-4)			16+(6-16) / 10+(6-16)			
Cables per clamp		2					2			2			
	solid AWG	18 - 10					16 - 10			12 - 10			
	flexible AWG	18 - 10					14 - 4			10 - 0			
Cables per clamp		2					1			1			
	solid AWG	10+(16-10) / 12+(18-12)					10+(16-10) / 12+(18-12)			10+(12-10) / 12+12			
	flexible AWG	14+(18-14) / 16+(18-16)					14+(18-14) / 16+(18-16)			1+(12-10) / 2+(8-12)			
Cables per clamp		2					2			2			
	solid AWG	10+(14-10) / 12+(18-12)					4+(18-12) / 6+(18-8)			3+(12-8) / 4+(10-6)			
	flexible AWG	14+(18-14) / 16+(18-16)					8+(18-8) / 10+(18-12)						
<b>Frequency of operations z</b>													
Contactors without thermal overload relay													
	without load 1/h	10000	10000	10000	10000	7000	7000	7000	7000	7000	7000		
	AC3, I <sub>o</sub> 1/h	600	600	600	600	600	600	600	600	400	400	400	
	AC4, I <sub>o</sub> 1/h	120	120	120	120	120	120	120	120	120	120	120	
	DC3, I <sub>o</sub> 1/h	600	600	600	600	600	600	600	600	400	400	400	
<b>Mechanical life</b>													
AC operated	S x 10 <sup>6</sup>	10	10	10	10	10	10	10	10	10	10	10	
DC operated	S x 10 <sup>6</sup>	10	10	10	10	10	10	10	10	10	10	10	
Short time current	10s-current A	96	120	144	176	184	240	296	360	504	592		
Power loss per pole	at I <sub>o</sub> /AC3 400V W	0,21	0,35	0,5	0,75	0,7	1,3	2	2,2	3,9	5,5		
<b>Resistance to shock acc. to IEC 68-2-27</b>													
Shock time 20ms sine-wave	NO g	10	10	10	10	8	8	8	8	8	8	8	
	NC g	6	6	6	6	-	-	-	-	-	-	-	

\*1) Suitable at 690V for: earthed-neutral systems, overvoltage I to IV, pollution degree 3 (standard-industry): U<sub>imp</sub> = 8kV.

Data for other conditions on request.

\*2) Metal halide lamps and sodium-vapour lamps (high- and low-pressure lamps)

\*3) High-pressure lamps

\*4) Blended lamps, containing a mercury high-pressure unit and a tungsten helix in a fluorescent glass bulb (daylight lamps)

\*5) Current inrush approx. 16 x I<sub>o</sub>

\*6) With reduced control voltage range 0,9 up to 1,0 x U<sub>s</sub> and with reduced rated current I<sub>o</sub>/AC1 according to I<sub>o</sub>/AC3



Main Contacts		Type	J7KN-85	J7KN-110	J7KN-150	J7KN-175	J7KN-200
Rated insulation voltage $U_i$ <sup>1)</sup>		V AC	750	750	690	690	690
Making capacity $I_m$		at $U_n = 690V$ AC A	1100	1200	1500	1800	1700
Breaking capacity $I_b$		400V AC A	950	1100	1200	1400	1600
J7KN-10 to J7KN-22 $\cos\phi = 0,65$		500V AC A	850	1000	1200	1400	1600
J7KN-24 to J7KN-72 $\cos\phi = 0,35$		690V AC A	600	600	700	800	1200
		1000V AC A	-	-	-	-	-
<b>Utilization category AC1</b>							
<b>Switching of resistive load</b>							
Rated operational current $I_o (=I_{n,o})$ at 40°C, open		A	150	170	200	250	350
Rated operational power of three-phase resistive loads 50-60Hz, $\cos\phi = 1$		220V kW	57	64	72	90	125
		230V kW	59	67	72	90	125
		240V kW	62	70	75	94	130
		380V kW	98	111	125	156	218
		400V kW	103	117	125	156	218
		415V kW	107	122	130	160	225
		440V kW	114	129	144	180	250
		500V kW	130	147	164	205	285
		660V kW	171	194	216	270	380
		690V kW	179	203	216	270	380
		1000V kW	-	-	-	-	-
Rated operational current $I_o (=I_{n,o})$ at 60°C, enclosed		A	100	125	160	200	280
Rated operational power of three-phase resistive loads 50-60Hz, $\cos\phi = 1$		220V kW	38	47	60	76	106
		230V kW	40	49	63	79	111
		240V kW	41	52	66	83	116
		380V kW	65	82	105	131	184
		400V kW	69	86	110	138	193
		415V kW	71	89	115	143	201
		440V kW	71	95	121	152	213
		500V kW	86	108	138	173	242
		660V kW	114	142	182	228	320
		690V kW	119	149	191	239	334
		1000V kW	-	-	-	-	-
Minimum cross-section of conductor at load with $I_o (=I_{n,o})$		mm <sup>2</sup>	50	70	95	120	185
<b>Utilization category AC2 and AC3</b>							
<b>Switching of three-phase motors</b>							
Rated operational current $I_o$ open and enclosed		220V A	85	110	150	175	210
		230V A	85	110	150	175	210
		240V A	85	110	150	175	210
		380-400V A	85	110	150	175	210
		415V A	85	110	150	175	210
		440V A	85	110	-	-	-
		500V A	60	60	-	-	-
		660-690V A	57,5	57,5	-	-	-
		1000V A	-	-	-	-	-
Rated operational power of three-phase motors 50-60Hz		220-230V kW	25	33	40	50	60
		240V kW	27	35	45	55	65
		380-400V kW	45	55	75	90	110
		415V kW	49	63	80	95	115
		440V kW	49	63	85	100	125
		500V kW	55	75	75	100	132
		660-690V kW	55	55	75	110	132
		1000V kW	-	-	-	-	-
<b>Utilization category AC4</b>							
<b>Switching of squirrel cage motors, inching</b>							
Rated operational current $I_o (=I_{n,o})$ open and enclosed		220V A	85	98	55	63	85
		230V A	85	98	55	63	85
		240V A	85	98	55	63	85
		380-400V A	85	85	55	63	85
		415V A	85	85	-	-	-
		440V A	85	85	-	-	-
		500V A	85	85	-	-	-
		660V A	60	60	-	-	-
		690V A	57,5	57,5	-	-	-
		1000V A	-	-	-	-	-

Main Contacts		Type	J7KN-85	J7KN-110	J7KN-150	J7KN-175	J7KN-200
Rated operational power of three-phase motors 50-60Hz	220-230V	kW	25	30	15	18,5	25
	240V	kW	27	32	15,5	19	26
	380-400V	kW	45	45	25	30	45
	415V	kW	49	49	25	33	45
	440V	kW	49	49	30	34	48
	500V	kW	55	55	25	30	55
	660-690V	kW	55	55	25	30	55
	1000V	kW	-	-	-	-	-
<b>Utilization category AC 5a</b>							
<b>Switching of gas discharge lamps</b>							
Rated operational current I <sub>o</sub> per pole at 220/230V							
Fluorescent lamps,							
uncompensated and serial compensated	A	100	120	120	140	180	
parallel compensated	A	55	70	85	100	120	
dual-connection	A	112	144	120	140	180	
Metal halide lamps <sup>2</sup> ,							
uncompensated	A	85	90	95	110	140	
parallel compensated	A	55	70	75	85	110	
Mercury-vapour lamps <sup>3</sup> ,							
uncompensated	A	112	144	120	140	180	
parallel compensated	A	55	70	75	85	110	
Mixed light lamps <sup>4</sup>							
A	100	120	100	120	160		
<b>Utilization category AC5b</b>							
<b>Switching of incandescent lamps<sup>5</sup></b>							
Rated operational current I <sub>o</sub> per pole at 220/230V	A	69	75	100	120	160	
<b>Utilization category AC6a</b>							
<b>Transformer primary switching</b>							
at inrush							
	n	30	30	30	30	30	
Rated operational current I <sub>o</sub>	400V A	38	50	65	80	90	
Rated operational power dependent on inrush n							
220-230V	kVA	15	20	25	30	34	
240V	kVA	15,5	20,5	27	33	37	
380-400V	kVA	26	34	45	55	60	
415-440V	kVA	29	38	46	57	63	
For different inrush-factors x use the following formula: P <sub>x</sub> =P <sub>n</sub> *(n/x)							
500V	kVA	33	43	55	69	75	
660-690V	kVA	45	60	56	69	100	
<b>Utilization category AC6b</b>							
<b>Switching of three-phase capacitor banks</b>							
Maximum inrush current (peak value) as multiple k of the capacitor rated current							
	k	20	20	20	20	15	
Rated operational current I <sub>o</sub>							
500V	A	87	100	120	155	195	
Rated operational power (sinφ→1)							
220-230V	kVAr	33	38	45	60	75	
240V	kVAr	36	42	52	62	78	
380-400V	kVAr	57	65	80	100	130	
415-440V	kVAr	60	70	95	110	135	
For different multiples x use the following formula: P <sub>x</sub> =P <sub>k</sub> *(k/x)							
500V	kVAr	70	80	100	130	170	
660-690V	kVAr	70	80	100	130	170	
<b>Switching of detuned capacitors</b>							
Rated operational current I <sub>o</sub>							
690V	A	98	105	115	140	200	
Rated operational power							
220-230V	kVAr	35	40	43	53	76	
240V	kVAr	39	43	45	55	80	
380-400V	kVAr	68	75	75	90	130	
415-440V	kVAr	71	77	80	100	140	
500V	kVAr	85	90	95	120	170	
660-690V	kVAr	110	120	125	150	200	
<b>Utilization category DC1</b>							
<b>Switching of resistive load</b>							
Time constant L/R ≤1ms							
Rated operational current I <sub>o</sub>							
1 pole	24V A	150	170	-	-	-	
	60V A	150	170	-	-	-	
	110V A	20	25	-	-	-	
	220V A	2	2,5	-	-	-	
3 poles in series	24V A	150	170	200	250	350	
	60V A	150	170	200	250	350	
	110V A	150	170	150	170	250	
	220V A	100	160	80	100	150	

Main Contacts		Type	J7KN-85	J7KN-110	J7KN-150	J7KN-175	J7KN-200
<b>Utilization category DC3 and DC5</b>							
<b>Switching of shunt motors and series motors</b>							
Time constant L/R ≤15ms							
Rated operational current I <sub>e</sub>	1 pole	24V A	150	170	-	-	-
		60V A	85	110	-	-	-
		110V A	2	2,5	-	-	-
		220V A	0,5	0,5	-	-	-
	3 poles in series	24V A	150	170	-	-	-
		60V A	100	110	-	-	-
		110V A	100	110	-	-	-
		220V A	7	8	-	-	-
<b>Maximum ambient temperature</b>							
Operation	open	°C	-40 to +60 (+90) <sup>6</sup>		-25 to +55 (+70) <sup>7</sup>		
	enclosed	°C	-40 to +40		-25 to +40		
with thermal overload relay	open	°C	-25 to +60		-25 to +55		
	enclosed	°C	-25 to +40		-25 to +40		
Storage		°C	-50 to +90		-55 to +80		
<b>Short circuit protection</b> for contactors without thermal overload relay							
Coordination-type "1" according to IEC 947-4-1 Contact welding without hazard of persons							
max. fuse size	gL (gG) A		250	250	250	315	400
Coordination-type "2" according to IEC 947-4-1 Light contact welding accepted							
max. fuse size	gL (gG) A		160	200	200	250	315
Contact welding not accepted							
max. fuse size	gL (gG) A		100	125	160	200	250
For contactors with thermal overload relay the device with the smaller admissible backup fuse (contactor or thermal overload relay) determines the fuse size.							
<b>Cable cross-sections</b> for contactors without thermal overload relay							
main connector	solid or stranded	mm <sup>2</sup>	10 - 70 <sup>8</sup>	10 - 70 <sup>8</sup>	95	120	185
	flexible	mm <sup>2</sup>	6 - 50 <sup>8</sup>	16 - 50 <sup>8</sup>	screw	screw	screw
	flexible with multicore cable end	mm <sup>2</sup>	10 - 35	10 - 35	M8	M8	M8
Cables per clamp	solid or stranded	mm <sup>2</sup>					
	flexible	mm <sup>2</sup>					
Cables per clamp	solid	AWG	10	10			
	flexible	AWG	6 - 0	6 - 0			
Cables per clamp	solid	AWG	1	1			
	flexible	AWG					
<b>Frequency of operations z</b> Contactors without thermal overload relay							
	without load	1/h	3000	3000	1200	1200	1200
	AC3, I <sub>e</sub>	1/h	300	300	-	-	-
	AC4, I <sub>e</sub>	1/h	120	120	-	-	-
	DC3, I <sub>e</sub>	1/h	300	300	-	-	-
<b>Mechanical life</b>							
AC operated	S x 10 <sup>6</sup>		5	5	10	10	8
DC operated	S x 10 <sup>6</sup>		5	5	10	10	8
<b>Short time current</b>							
	10s-current	A	680	880	1200	1400	1800
<b>Power loss per pole</b>							
	at I <sub>e</sub> /AC3	400V W	4,3	6,0	8	11	8
<b>Resistance to shock acc. to IEC 68-2-27</b>							
Shock time 20ms sine-wave	NO	g	7	7	-	-	-
	NC	g	5	5	-	-	-

- \*1) Suitable at 690V for: earthed-neutral systems, overvoltage I to IV, pollution degree 3 (standard-industry):  
U<sub>imp</sub> = 8kV. Data for other conditions on request.
- \*2) Metal halide lamps and sodium-vapour lamps (high- and low-pressure lamps)
- \*3) High-pressure lamps
- \*4) Blended lamps, containing a mercury high-pressure unit and a tungsten helix in a fluorescent glass bulb (daylight lamps)
- \*5) Current inrush approx. 16 x I<sub>e</sub>
- \*6) With reduced control voltage range 0,9 up to 1,0 x U<sub>s</sub> and with reduced rated current I<sub>e</sub>/AC1 according to I<sub>e</sub>/AC3
- \*7) With reduced control voltage range 1,0 x U<sub>s</sub> and with reduced rated current I<sub>e</sub>/AC1 according to I<sub>e</sub>/AC3
- \*8) Maximum cable cross-section with prepared conductor

## Contactors

### Data according to IEC 947-4-1, EN 60947-4-1, VDE 0660

Auxiliary Contacts		Type	J7KN-10	J7KN-14	J7KN-18	J7KN-22	J7KN-24	J7KN-32	J7KN-40	J7KN-50	J7KN-62	J7KN-74
Rated insulation voltage U <sub>i</sub> <sup>1)</sup>		V~	690	690	690	690	-	-	-	-	-	-
Thermal rated current I <sub>n</sub> to 690V												
Ambient temperature		40°C A	16	16	16	16	-	-	-	-	-	-
		60°C A	12	12	12	12	-	-	-	-	-	-
<b>Utilization category AC15</b>												
Rated operational current I <sub>n</sub>		220-240V A	12	12	12	12	-	-	-	-	-	-
		380-415V A	4	4	4	4	-	-	-	-	-	-
		440V A	4	4	4	4	-	-	-	-	-	-
		500V A	3	3	3	3	-	-	-	-	-	-
		660-690V A	1	1	1	1	-	-	-	-	-	-
<b>Utilization category DC13</b>												
Rated operational current I <sub>n</sub>		60V A	8	8	8	8	-	-	-	-	-	-
		110V A	1	1	1	1	-	-	-	-	-	-
		220V A	0,1	0,1	0,1	0,1	-	-	-	-	-	-
<b>Short circuit protection</b>												
short-circuit current 1kA, contact welding not accepted												
max. fuse size		gL (gG) A	25	25	25	25	-	-	-	-	-	-
For contactors with thermal overload relay the device with the smaller admissible control fuse (contactor or thermal overload relay) determines the fuse.												
<b>Control Circuit</b>												
<b>Power consumption of coils</b>												
AC operated		inrush VA	33-45				90-115			140-165		
		sealed VA	7-10				9-13			13-18		
		W	2,6-3				2,7-4			5,4-7		
DC operated		inrush W	75				140			200		
		sealed W	2				2			6		
<b>Operation range of coils</b>												
in multiples of control voltage U <sub>c</sub>		AC operated	0,85-1,1				0,85-1,1			0,85-1,1		
		DC operated	0,8-1,1				0,8-1,1			0,8-1,1		
<b>Switching time</b> at control voltage U <sub>c</sub> ±10% <sup>2),3)</sup>												
AC operated		make time ms	8-16				10-25			12-28		
		release time ms	5-13				8-15			8-15		
		arc duration ms	10-15				10-15			10-15		
DC operated		make time ms	8-12				10-20			12-23		
		release time ms	8-13				10-15			10-18		
		arc duration ms	10-15				10-15			10-15		
<b>Cable cross-section</b>												
Auxiliary connector		solid mm <sup>2</sup>	0,75-6				-			-		
		flexible mm <sup>2</sup>	1-4				-			-		
flexible with multicore cable end		mm <sup>2</sup>	0,75-4				-			-		
Magnet coil		solid mm <sup>2</sup>	0,75-2,5				0,75-2,5			0,75-2,5		
		flexible mm <sup>2</sup>	0,5-2,5				0,5-2,5			0,5-2,5		
		flexible with multicore cable end mm <sup>2</sup>	0,5-1,5				0,5-1,5			0,5-1,5		
Clamps per pole			2				2			2		
Auxiliary connector		solid AWG	18 - 10-				-			-		
		flexible AWG	18 - 10				-			-		
Magnet coil		solid AWG	14 - 12				14 - 12			14 - 12		
		flexible AWG	18 - 12				18 - 12			18 - 12		
Clamps per pole			2				2			2		

\*1) Suitable for: earthed-neutral systems, overvoltage category I to IV, pollution degree 3 (standard-industry): U<sub>imp</sub> = 8kV. Data for other conditions on request

\*2) Total breaking time = release time + arc duration

\*3) Values for delay of the release time of the making contact and the make time of the break contact will be increased, if magnet coils are protected against voltage peaks (varistor, RC-unit, diode-unit)

Auxiliary Contacts		Type	J7KN-85	J7KN-110	J7KN-150	J7KN-175	J7KN-200
Rated insulation voltage U <sub>i</sub> *1		V~	690	690	690	690	690
Thermal rated current I <sub>n</sub> to 690V							
Ambient temperature		40°C A	16	16	10	10	10
		60°C A	12	12	-	-	-
<b>Utilization category AC15</b>							
Rated operational current I <sub>e</sub>		220-240V A	12	12	3	3	3
		380-415V A	6	6	2	2	2
		440V A	6	6	1,5	1,5	1,5
		500V A	4	4	1,5	1,5	1,5
		660-690V A	2	2	1	1	1
<b>Utilization category DC13</b>							
Rated operational current I <sub>e</sub>		60V A	8	8	-	-	-
		110V A	1	1	0,5	0,5	1
		220V A	0,1	0,1	0,2	0,2	0,5
<b>Short circuit protection</b>							
short-circuit current 1kA, contact welding not accepted							
max. fuse size		gL (gG) A	25	25	10	10	10
For contactors with thermal overload relay the device with the smaller admissible control fuse (contactor or thermal overload relay) determines the fuse.							
<b>Control Circuit</b>							
<b>Power consumption of coils</b>							
AC operated		inrush VA	280-350	350-420	550	550	1100
		sealed VA	16 -23	23 -29	120	120	66
		W	4-6	6-7,3	-	-	-
DC operated		inrush W	170	320	160	160	530
		sealed W	2	4	5	5	21
<b>Operation range of coils</b>							
in multiples of control voltage U <sub>c</sub>		AC operated	0,85-1,1		0,85-1,1	0,85-1,1	0,85-1,1
		DC operated	0,8-1,1		0,85-1,1	0,85-1,1	0,85-1,1
<b>Switching time at control voltage U<sub>c</sub> ±10%<sup>2,3</sup></b>							
AC operated		make time ms	13-30		12-30	12-30	30-40
		release time ms	8-15		15-40	15-40	15-45
		arc duration ms	10-15		-	-	-
DC operated		make time ms	20-30		-	-	-
		release time ms	10-18		-	-	-
		arc duration ms	10-15		-	-	-
<b>Cable cross-section</b>							
Auxiliary connector		solid mm <sup>2</sup>	0,75-2,5		0,75-2,5		
		flexible mm <sup>2</sup>	0,75-2,5		0,75-2,5		
flexible with multicore cable end		mm <sup>2</sup>	0,5-1,5		-		
Magnet coil		solid mm <sup>2</sup>	0,75-2,5		1-2,5		
		flexible mm <sup>2</sup>	0,5-2,5		1-2,5		
		flexible with multicore cable end mm <sup>2</sup>	0,5-1,5		-		
Clamps per pole			14 - 12		16 - 12		
Auxiliary connector		solid AWG	18 - 12		16 - 12		
		flexible AWG	14 - 12		16 - 12		
Magnet coil		solid AWG	18 - 12		16 - 12		
		flexible AWG	2		2		
Clamps per pole			0,75-2,5		0,75-2,5		

\*1) Suitable for: earthed-neutral systems, overvoltage category I to IV, pollution degree 3 (standard-industry): U<sub>imp</sub> = 8kV. Data for other conditions on request

\*2) Total breaking time = release time + arc duration

\*3) Values for delay of the release time of the making contact and the make time of the break contact will be increased, if magnet coils are protected against voltage peaks (varistor, RC-unit, diode-unit)

## Contactors for North America

### Data according to UL508

Main Contacts (cULus)	Type	J7KN-10	J7KN-14	J7KN-18	J7KN-22	J7KN-24	J7KN-32	J7KN-40	J7KN-50	J7KN-62	J7KN-74
Rated operational current "General Use"	A	25	25	30	30	50	65	80	110	120	130
Rated operational power of three-phase motors at 60Hz (3ph)	110-120V hp	1½	2	2	3	5	5	7½	10	10	10
	200V hp	3	3	5	5	7½	10	10	15	20	25
	220-240V hp	3	3	7½	7½	10	10	15	20	25	30
	277V hp	3	5	7½	7½	7½	10	15	20	25	30
	380-415V hp	5	5	10	10	10	15	20	25	30	40
	440-480V hp	5	7½	10	15	15	20	25	30	40	50
Rated operational power of AC motors at 60Hz (1ph)	550-600V hp	7½	10	15	20	20	25	30	40	50	50
	110-120V hp	½	¾	1	1½	1½	2	3	3	5	7½
	200V hp	1	1,5	2	3	3	5	7½	7½	10	15
	220-240V hp	1½	2	3	3	5	5	7½	10	15	15
	277V hp	2	3	3	5	5	7½	10	10	15	15
	380-415V hp	3	3	5	5	5	7½	10	15	20	20
Rated operational power of three-phase motors at 60Hz (3ph) for elevators	440-480V hp	3	5	5	7½	7½	10	15	20	25	25
	550-600V hp	3	5	7½	10	10	15	20	25	30	30
	110-120V hp	-	-	-	-	2	3	-	3	5	-
	200V hp	-	-	-	-	3	5	-	7½	10	-
	220-240V hp	-	-	-	-	5	7½	-	7½	10	-
	550-600V hp	-	-	-	-	10	15	-	20	25	-
Demands according to ANSI A17.5 (500.000 operations)	440-480V hp	-	-	-	-	10	15	-	20	25	-
	550-600V hp	-	-	-	-	10	20	-	25	30	-
Rated operational current	600V A	-	-	-	-	15	22	-	27	37	-
Fuses	A	30	40	50	50	90	125	175	175	225	250
Suitable for use on a capability of delivering not more than	rms A	5000	5000	5000	5000	5000	5000	5000	5000	5000	5000
	V	600	600	600	600	600	600	600	600	600	600
Auxiliary Contacts (cULus)		A600	A600	A600	A600	-	-	-	-	-	-

Main Contacts (cULus)	Type	J7KN-85	J7KN-110	J7KN-150	J7KN-175	J7KN-200
Rated operational current "General Use"	A	125	125	-	-	-
Rated operational power of three-phase motors at 60Hz (3ph)	110-120V hp	15	-	-	-	-
	200V hp	-	30	-	-	-
	220-240V hp	35	40	-	-	-
	277V hp	-	-	-	-	-
	380-415V hp	-	-	-	-	-
	440-480V hp	65	75	-	-	-
Rated operational power of AC motors at 60Hz (1ph)	550-600V hp	85	100	-	-	-
	110-120V hp	8	10	-	-	-
	200V hp	-	20	-	-	-
	220-240V hp	20	20	-	-	-
	277V hp	-	-	-	-	-
	380-415V hp	-	-	-	-	-
Rated operational power of three-phase motors at 60Hz (3ph) for elevators	440-480V hp	-	50	-	-	-
	550-600V hp	-	60	-	-	-
	110-120V hp	-	-	-	-	-
	200V hp	-	-	-	-	-
	220-240V hp	-	-	-	-	-
	550-600V hp	-	-	-	-	-
Demands according to ANSI A17.5 (500.000 operations)	440-480V hp	-	-	-	-	-
	550-600V hp	-	-	-	-	-
Rated operational current	600V A	-	62	-	-	-
Fuses	A	-	300	-	-	-
Suitable for use on a capability of delivering not more than	rms A	10000	10000	-	-	-
	V	600	600	-	-	-
Auxiliary Contacts (cULus)		A600	A600	-	-	-

## Contactors

### Data according to IEC 947-4-1, EN 60947-4-1, VDE 0660

#### Contact Life

For selection of the suitable contactor-type according to supply voltage, power rating and application (utilization category AC1, AC3 or AC4) use contact life characteristic diagram.

For the most common supply voltages four scales of power ratings P<sub>n</sub> are provided for each utilization category.

Select contactor-type according to utilization category **AC3** (breaking current I<sub>b</sub> = I<sub>n</sub>) using the **motor rating** scales to the right, according to utilization category **AC4** (breaking current I<sub>b</sub> = 6 x I<sub>n</sub>) using the **motor rating** scales to the left.<sup>1</sup>

Select contactor-type according to utilization category **AC1** (breaking current I<sub>b</sub> = I<sub>n</sub>/AC1) using the **breaking current** scale.<sup>1</sup>

1. Pay attention to the approved rated values of the selected contactor according to the national approvals

For contactors frequently used under AC3/AC4-mixed service conditions calculate contact life with the formula:

$$M = \frac{AC3}{1 + \frac{\%AC4}{100} \times \left( \frac{AC3}{AC4} - 1 \right)}$$

M = Contact life (switching cycles) for AC3/AC4-mixed operations

AC3 = Contact life (switching cycles) for AC3 operations (normal switching conditions). Breaking current I<sub>b</sub> = rated motor current I<sub>n</sub>.

AC4 = Contact life (switching cycles) for AC4 operations (inching).

Breaking current I<sub>b</sub> = multiples of rated motor current I<sub>n</sub>.

%AC4 = Percents of AC4-operations related to the total cycles.

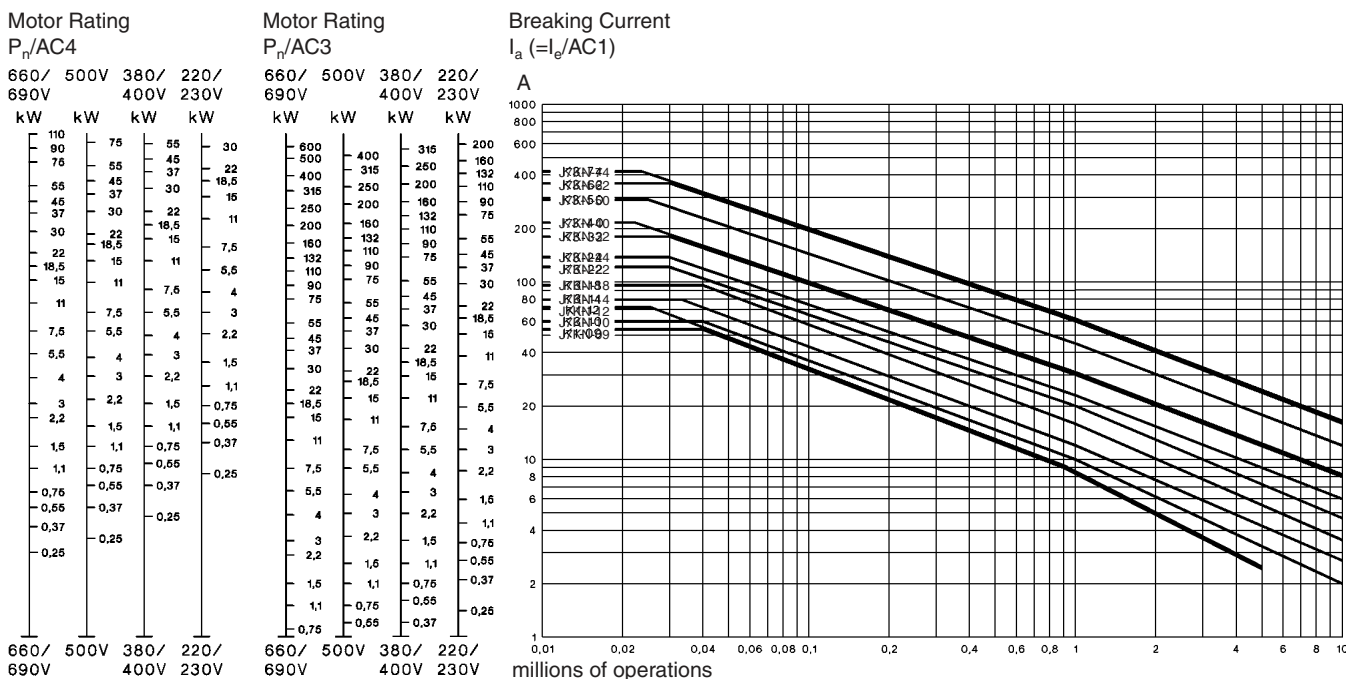

Motor Rating

$P_n/AC4$

660/ 500V 380/ 220/  
690V 400V 230V  
kW kW kW kW

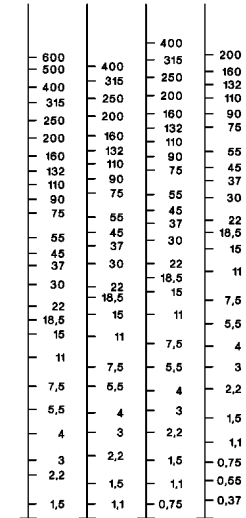

Motor Rating

$P_n/AC3$

660/ 500V 380/ 220/  
690V 400V 230V  
kW kW kW kW

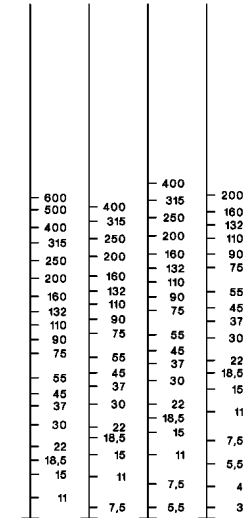

Breaking Current

$I_a (=I_g/AC1)$

A

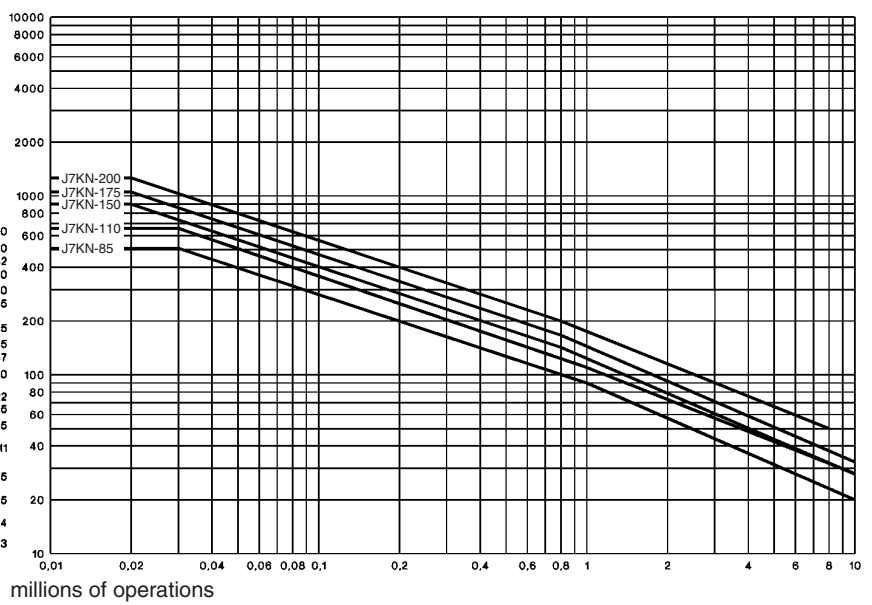



# Contactors

## Utilization Categories

For easier choice of devices and in order to make the comparison of different products simpler are utilization categories for contactors and motor-starters according to IEC 947-4-1 and VDE 0660 Part 102, for

control circuit devices and switching elements according to IEC 947-5-1 and VDE 0660 Part 200 determined. The table offers different utilization categories, typical applications and assorted test conditions.

Type of current	Category	Typical applications	Rated operational current	Test conditions for the number of on-load operating cycles						Test conditions for making and breaking capacities					
				Make I/le	U/Ue	cosφ	Break Ic/le	Ur/Ue	cosφ	Make I/le	U/Ue	cosφ	Break Ic/le	Ur/Ue	cosφ
Alternating Current	AC1	Non-inductive or slightly inductive loads-resistance furnaces	all values	1	1	0.95	1	1	0.95	1.5	1.05	0.8	1.5	1.05	0.8
	AC2	Slip-ring motors: starting, switching off	all values	2.5	1	0.65	2.5	1	0.65	4	1.05	0.65	4	1.05	0.65
	AC3	Squirrel-cage motors: starting, switching off motors during running	17A< le≤ 17A	6	1	0.65	1	0.17	0.65	10	1.05	0.45	8	1.05	0.45
			le≤ 100A	6	1	0.35	1	0.17	0.35	10	1.05	0.45	8	1.05	0.45
			le> 100A	6	1	0.35	1	0.17	0.35	10	1.05	0.35	8	1.05	0.35
	AC4	Squirrel-cage motors: starting, plugging, inching	17A< le≤ 17A	6	1	0.65	6	1	0.65	12	1.05	0.45	10	1.05	0.45
			le≤ 100A	6	1	0.35	6	1	0.35	12	1.05	0.45	10	1.05	0.45
			le> 100A	6	1	0.35	6	1	0.35	12	1.05	0.35	10	1.05	0.35
	AC5a	Switching of electric discharge lamp controls	all values	-	-	-	-	-	-	3	1.05	0.45	3	1.05	0.45
	AC5b	Switching of incandescent lamps	all values	-	-	-	-	-	-	1.5	1.05	1)	4	1.05	1)
	AC6a	Switching of transformers	le≤ 100A	-	-	-	-	-	-	4.5	1.05	0.45	3.6	1.05	0.45
			le> 100A	-	-	-	-	-	-	4.5	1.05	0.35	3.6	1.05	0.35
	AC6b	Switching of capacitor banks	-	-	-	-	-	-	-	2)			2)		
	AC7a	Slightly inductive loads in household appliances and similar applications	all values	-	-	-	-	-	-	1.5	1.05	0.8	1.5	1.05	0.8
	AC7b	Motor loads for household applications	le≤ 100A	-	-	-	-	-	-	8	1.05	0.45	6	1.05	0.45
le> 100A			-	-	-	-	-	-	8	1.05	0.35	6	1.05	0.35	
AC8a	Hermetic refrigerant compressor motor control with manual resetting of overload releases	le≤ 100A	-	-	-	-	-	-	6	1.05	0.45	6	1.05	0.45	
		le> 100A	-	-	-	-	-	-	6	1.05	0.35	6	1.05	0.35	
AC8b	Hermetic refrigerant compressor motor control with automatic resetting of overload releases	le≤ 100A	-	-	-	-	-	-	6	1.05	0.45	6	1.05	0.45	
		le> 100A	-	-	-	-	-	-	6	1.05	0.35	6	1.05	0.35	
AC12	Control of resistive loads and solid state loads with isolation by opto couplers	all values	-	-	-	-	-	-	1	1	0.9	1	1	0.9	
AC13	Control of solid state loads with transformer isolation	all values	-	-	-	-	-	-	10	1.1	0.65	1.1	1.1	0.65	
AC14	Control of small electromagnetic loads (<=72VA)	-	-	-	-	-	-	-	6	1.1	0.7	6	1.1	0.7	
AC15	Control of electromagnetic load (>72VA)	-	10	1	0.7	1	1	0.4	10	1.1	0.3	10	1.1	0.3	
				Make I/le	U/Ue	L/R [ms]	Break Ic/le	Ur/Ue	L/R [ms]	Make I/le	U/Ue	L/R [ms]	Break Ic/le	Ur/Ue	L/R [ms]
Direct Current	DC1	Non-inductive or slightly inductive loads resistance furnaces	all values	1	1	1	1	1	1	1.5	1.05	1	1.5	1.05	1
	DC3	Shunt-motors: starting, plugging, inching dynamic braking of d.c. motors	all values	2.5	1	2	2.5	1	2	4	1.05	2.5	4	1.05	2.5
	DC5	Series-motors: starting, plugging, inching dynamic braking of d.c. motors	all values	2.5	1	7.5	2.5	1	7.5	4	1.05	15	4	1.05	15
	DC6	Switching of incandescent lamps	all values	-	-	-	-	-	-	1.5	1.05	1)	4	1.05	1)
	DC12	Control of resistive loads and solid state loads with isolation by opto couplers	all values	-	-	-	-	-	-	1	1	1	1	1	1
	DC13	Control of electromagnets	all values	1	1	≤300	1	1	≤300	1.1	1.1	≤300	1.1	1.1	≤300
	DC14	Control of electromagnetic loads having economy resistors in circuit	all values	-	-	-	-	-	-	10	1.1	15	10	1.1	15

U, Rated operational voltage, U Voltage before make, U, Recovery voltage, I, Rated operational current, I Current make, I, Current broken

- 1) Test with incandescent lamps
- 2) Test conditions according to standard

## Accessories

### Data according to IEC 947-5-1, EN 60947-5-1, VDE 0660

Auxiliary Contacts	Type	J73KN-B	J73KN-C	J73KN-B-TP...
Rated insulation voltage $U_i^{*1}$	V~	690	690	690
Thermal rated current $I_n$ to 690V				
Ambient temperature	40°C A	10	10	10
	60°C A	6	6	-
Frequency of operations z	1/h	3000	3000	1200
Mechanical life	S x 10 <sup>6</sup>	10	10	1
Power loss per pole at I <sub>n</sub> /AC1	W	0,5	0,5	-
Utilization category AC15				
Rated operational current I <sub>n</sub>	220-240V A	3	3	4
	380-400V A	2	2	3
	440V A	1,6	1,6	2
	500V A	1,2	1,2	2
	660-690V A	0,6	0,6	2
Utilization category DC13				
Rated operational current I <sub>n</sub>	60V A	2	2	2,5
	110V A	0,4	0,4	1,5
	220V A	0,1	0,1	0,2
Short circuit protection				
short-circuit current 1kA, contact welding not accepted max. fuse size	gL (gG) A	20	20	10
For contactors with thermal overload relay or auxiliary contacts the device with the smaller admissible control fuse (contactor or thermal overload relay) determines the fuse size.				
Cable cross-sections				
	solid or stranded mm <sup>2</sup>	0,75-2,5	0,75-2,5	1-2,5
	flexible mm <sup>2</sup>	0,75-2,5	0,75-2,5	0,75-2,5
	flexible with multicore cable end mm <sup>2</sup>	0,5-1,5	0,5-1,5	0,75-2,5
Cables per clamp		2	2	2

\*1) Suitable for: earthed-neutral systems, overvoltage category I to IV, pollution degree 3 (standard-industry):  $U_{imp} = 8kV$ . Data for other conditions on request

### Data according to CSA, UL and CUL

Auxiliary Contacts	Type	J73KN-B	J73KN-C	J73KN-B-TP...
Rated operational current „General Use“	A	10	10	10
Rated operational voltage	max. V AC	600	600	600
Auxiliary Contacts		A600	A600	A600

## Contactors and Accessories

### Wiring diagrams

#### Auxiliary contact blocks

J73KN-B-10

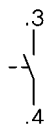

J73KN-B-01

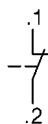

J73KN-C-11S\*1

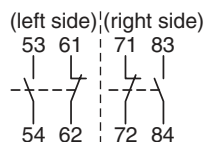

#### Pneumatic timer

on-delayed  
J74KN-B-TP...DA

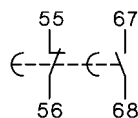

off-delayed  
J74KN-B-TP...IA

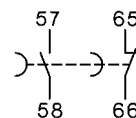

\*1) Correct terminal marking is given by mounting

■ Dimensions

AC operated

J7KN-10...  
 J7KN-10-4  
 J7KN-14...  
 J7KN-18...  
 J7KN-22...

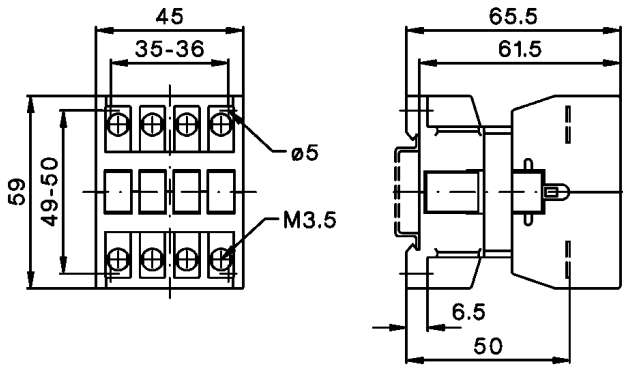

J7KN-24...  
 J7KN-32...  
 J7KN-40...

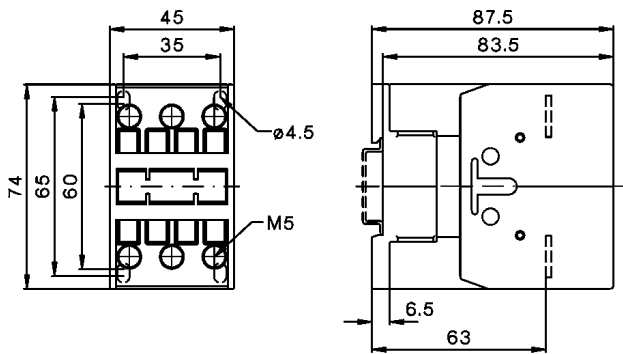

J7KN-50...  
 J7KN-62...  
 J7KN-74...

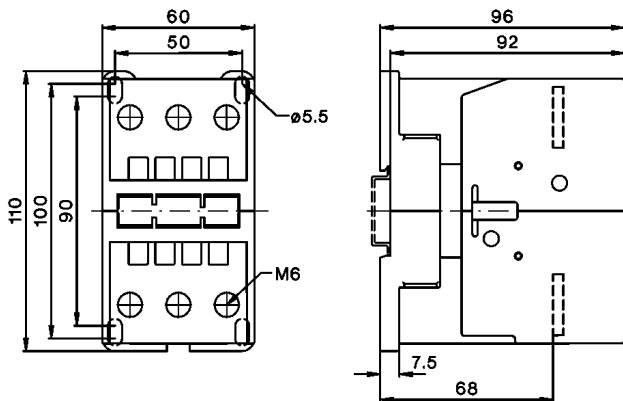

DC operated

J7KN-10...D  
 J7KN-14...D  
 J7KN-18...D  
 J7KN-22...D

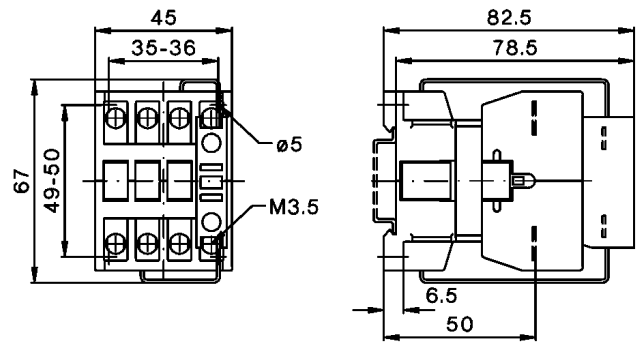

J7KN-24...D  
 J7KN-32...D  
 J7KN-40...D

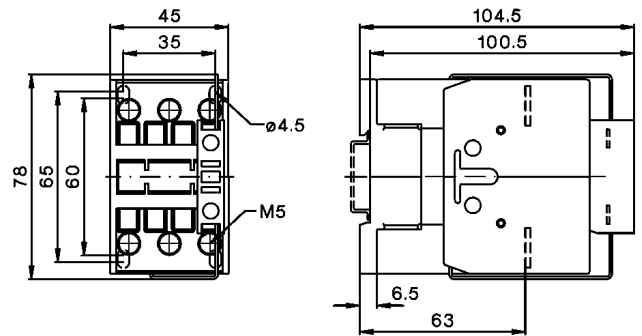

J7KN-50...D  
 J7KN-62...D  
 J7KN-74...D

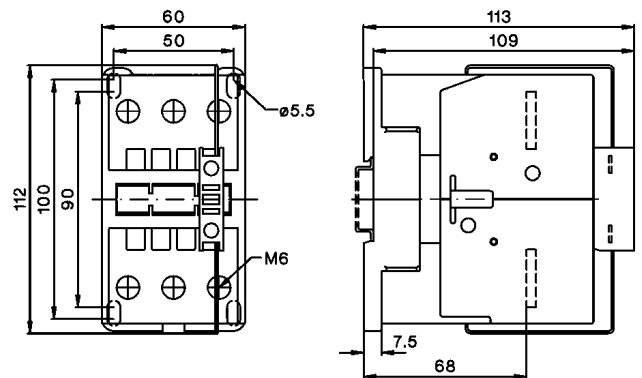

AC operated

J7KN-85...  
J7KN-110...

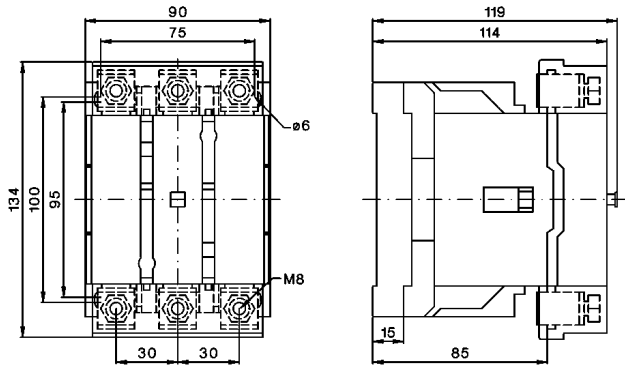

J7KN-200...

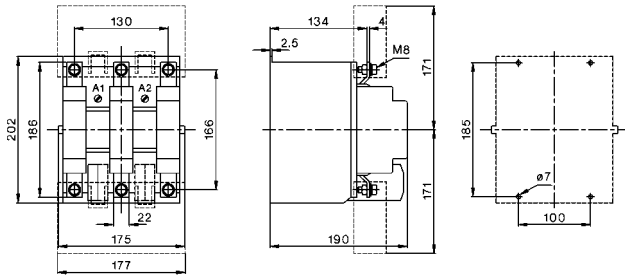

J7KN-150...  
J7KN-175...

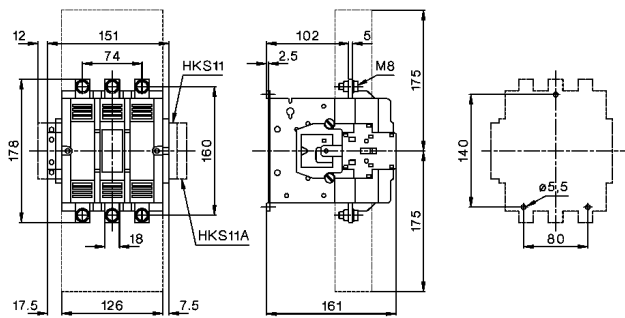

Auxiliary contact blocks

J73KN-B-01  
J73KN-B-10

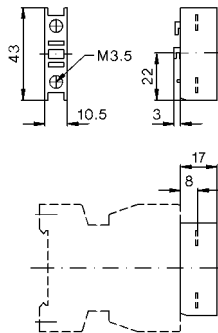

Pneumatic timer

J74KN-B-TP...

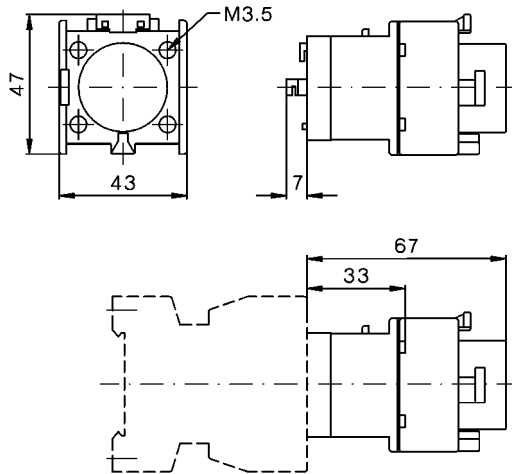

Auxiliary contact blocks

J73KN-C-11S

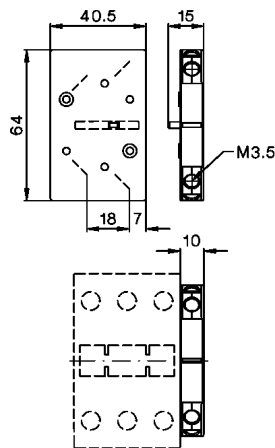

Auxiliary contact blocks

J74KN-A-VG

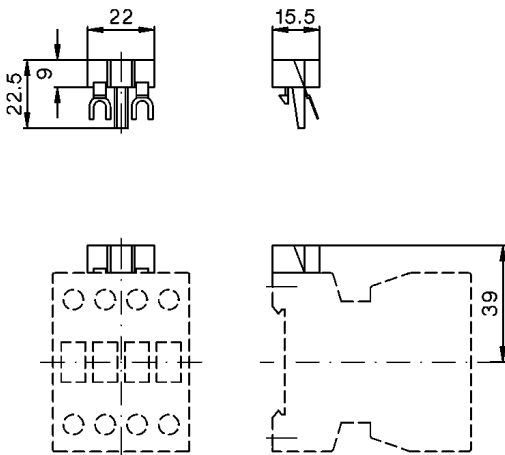

J74KN-A-RC

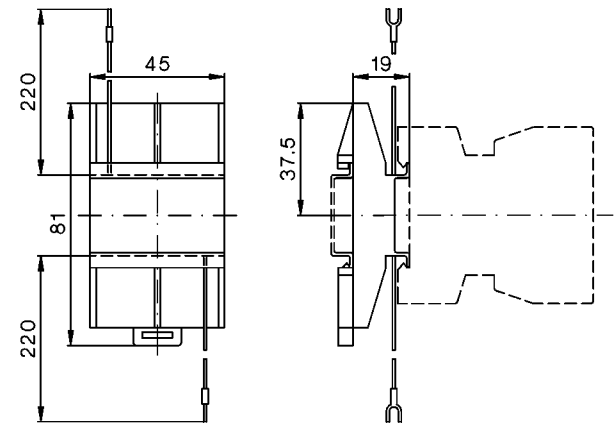

J74KN-B-VG

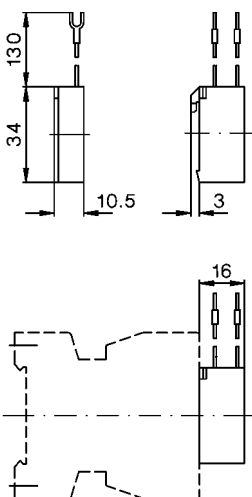

J74KN-B-RC

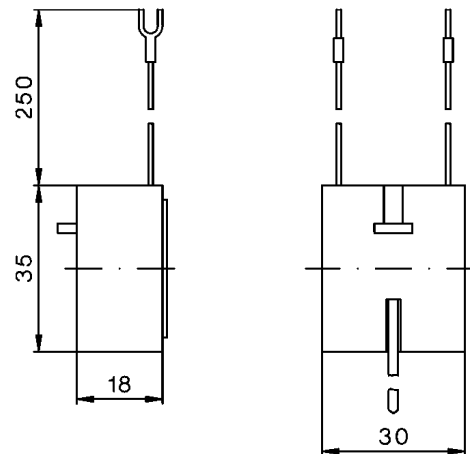

Position of Terminals

AC operated

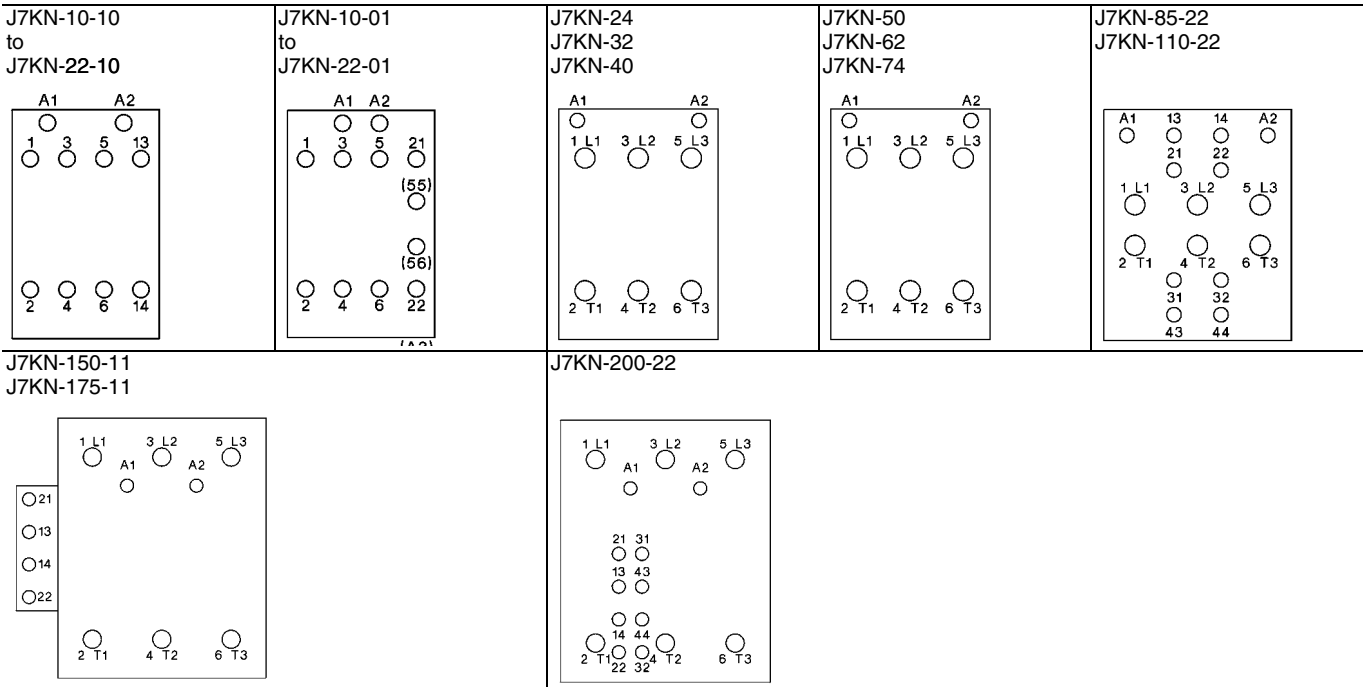

DC operated with double winding coil

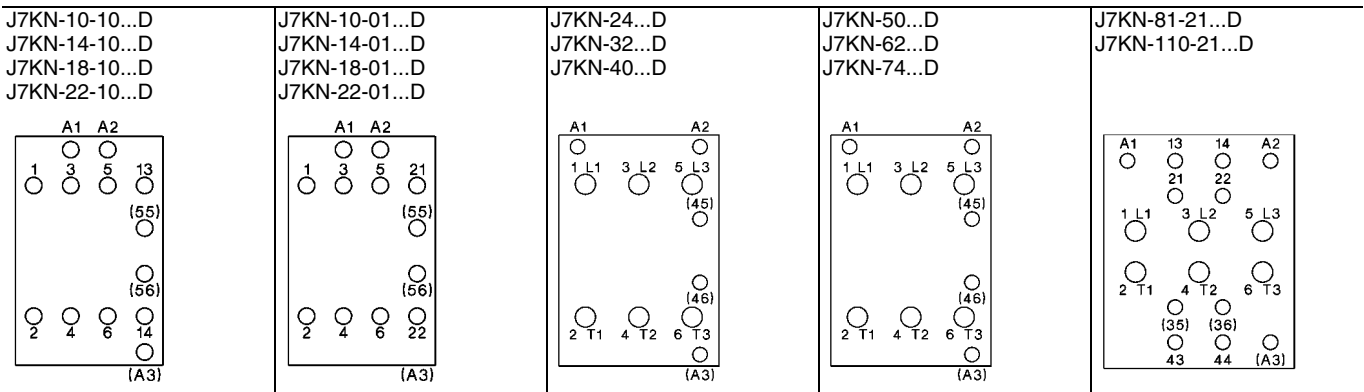

ALL DIMENSIONS SHOWN ARE IN MILLIMETERS.  
To convert millimeters into inches, multiply by 0.03937. To convert grams into ounces, multiply by 0.03527.