

Rambus™ XDR™ Clock Generator

General Description

The **ICS9214** clock generator provides the necessary clock signals to support the Rambus XDR™ memory subsystem and Redwood logic interface. The clock source is a reference clock that may or may not be modulated for spread spectrum. The **ICS9214** provides 4 differential clock pairs in a space saving 28-pin TSSOP package and provides an off-the-shelf high-performance interface solution.

Figure 1 shows the major components of the **ICS9214** XDR Clock Generator. These include the a PLL, a Bypass Multiplexer and four differential output buffers. The outputs can be disabled by a logic low on the OE pin. An output is enabled by the combination of the OE pin being high, and 1 in its SMBus Output control register bit.

The PLL receives a reference clock, CLK_INT/C and outputs a clock signal at a frequency equal to the input frequency times a multiplier. Table 2 shows the multipliers selectable via the SMBus interface. This clock signal is then fed to the differential output buffers to drive the enabled clocks. Disabled outputs are set to Hi-Z. The Bypass mode routes the input clock, CLK_INT/C, directly to the differential output buffers, bypassing the PLL.

Up to four **ICS9214** devices can be cascaded on the same SMBus. Table 3 shows the SMBus addressing and control for the four devices.

Features

- 400 – 500 MHz clock source
- 4 open-drain differential output drives with short term jitter < 40ps
- Spread spectrum compatible
- Reference clock is differential or single-ended, 100 or 133 MHz
- SMBus programmability for:
 - frequency multiplier
 - output enable
 - operating mode
- Supports frequency multipliers of: 3, 4, 5, 6, 8, 9/2, 15/2 and 15/4
- Support systems where XDR subsystem is asynchronous to other system clocks
- 2.5V power supply

Block Diagram

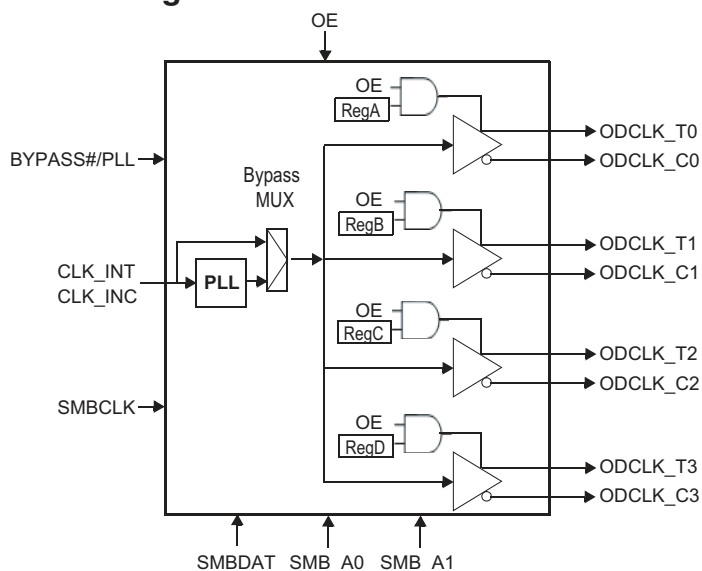

Pin Configuration

AVDD2.5	1	28	VDD2.5
AGND	2	27	ODCLK_T0
IREFY	3	26	ODCLK_C0
AGND	4	25	GND
CLK_INT	5	24	ODCLK_T1
CLK_INC	6	23	ODCLK_C1
VDD2.5	7	22	VDD2.5
GND	8	21	GND
SMBCLK	9	20	ODCLK_T2
SMBDAT	10	19	ODCLK_C2
OE	11	18	GND
SMB_A0	12	17	ODCLK_T3
SMB_A1	13	16	ODCLK_C3
BYPASS#/PLL	14	15	VDD2.5

28-Pin 4.4mm TSSOP

Pin Descriptions

PIN #	PIN NAME	PIN TYPE	DESCRIPTION
1	AVDD2.5	PWR	2.5V Analog Power pin for Core PLL
2	AGND	PWR	Analog Ground pin for Core PLL
3	IREFY	IN	This pin establishes the reference current for the differential clock pairs. This pin requires a fixed precision resistor tied to ground in order to establish the appropriate current.
4	AGND	PWR	Analog Ground pin for Core PLL
5	CLK_INT	IN	"True" reference clock input.
6	CLK_INC	IN	"Complementary" reference clock input.
7	VDD2.5	PWR	Power supply, nominal 2.5V
8	GND	PWR	Ground pin.
9	SMBCLK	IN	Clock pin of SMBUS circuitry, 5V tolerant
10	SMBDAT	I/O	Data pin of SMBUS circuitry, 5V tolerant
11	OE	IN	Active high input for enabling outputs. 0 = tri-state outputs, 1= enable outputs
12	SMB_A0	IN	SMBus address bit 0 (LSB)
13	SMB_A1	IN	SMBus address bit 1
14	BYPASS#/PLL	IN	Input to select Bypass(fan-out) or PLL (ZDB) mode 0 = Bypass mode, 1= PLL mode
15	VDD2.5	PWR	Power supply, nominal 2.5V
16	ODCLK_C3	OUT	"Complementary" side of open drain differential clock output. This open drain output needs an external resistor network..
17	ODCLK_T3	OUT	"True" side of open drain differential clock output. This open drain output needs an external resistor network..
18	GND	PWR	Ground pin.
19	ODCLK_C2	OUT	"Complementary" side of open drain differential clock output. This open drain output needs an external resistor network..
20	ODCLK_T2	OUT	"True" side of open drain differential clock output. This open drain output needs an external resistor network..
21	GND	PWR	Ground pin.
22	VDD2.5	PWR	Power supply, nominal 2.5V
23	ODCLK_C1	OUT	"Complementary" side of open drain differential clock output. This open drain output needs an external resistor network..
24	ODCLK_T1	OUT	"True" side of open drain differential clock output. This open drain output needs an external resistor network..
25	GND	PWR	Ground pin.
26	ODCLK_C0	OUT	"Complementary" side of open drain differential clock output. This open drain output needs an external resistor network..
27	ODCLK_T0	OUT	"True" side of open drain differential clock output. This open drain output needs an external resistor network..
28	VDD2.5	PWR	Power supply, nominal 2.5V

General SMBus serial interface information for the ICS9214

How to Write:

- Controller (host) sends a start bit.
- Controller (host) sends the write address $D8_{(H)}$
- ICS clock will **acknowledge**
- Controller (host) sends the beginning byte location = N
- ICS clock will **acknowledge**
- Controller (host) sends the data byte count = X
- ICS clock will **acknowledge**
- Controller (host) starts sending **Byte N through Byte N + X - 1**
- ICS clock will **acknowledge** each byte **one at a time**
- Controller (host) sends a Stop bit

How to Read:

- Controller (host) will send start bit.
- Controller (host) sends the write address $D8_{(H)}$
- ICS clock will **acknowledge**
- Controller (host) sends the beginning byte location = N
- ICS clock will **acknowledge**
- Controller (host) will send a separate start bit.
- Controller (host) sends the read address $D9_{(H)}$
- ICS clock will **acknowledge**
- ICS clock will send the data byte count = X
- ICS clock sends **Byte N + X - 1**
- ICS clock sends **Byte 0 through byte X (if $X_{(H)}$ was written to byte 8).**
- Controller (host) will need to acknowledge each byte
- Controller (host) will send a not acknowledge bit
- Controller (host) will send a stop bit

Index Block Write Operation		
Controller (Host)		ICS (Slave/Receiver)
T	starT bit	
Slave Address $D8_{(H)}$		
WR	WRite	
		ACK
Beginning Byte = N		
		ACK
Data Byte Count = X		
		ACK
Beginning Byte N		X Byte
◊		
◊		
◊		
Byte N + X - 1		
		ACK
P	stoP bit	

Index Block Read Operation		
Controller (Host)		ICS (Slave/Receiver)
T	starT bit	
Slave Address $D8_{(H)}$		
WR	WRite	
		ACK
Beginning Byte = N		
		ACK
RT	Repeat starT	
Slave Address $D9_{(H)}$		
RD	ReaD	
		ACK
		Data Byte Count = X
ACK		
ACK		X Byte
◊		
◊		
◊		
		Byte N + X - 1
N	Not acknowledge	
P	stoP bit	

SMB Table: Output Control Register

Byte 0		Pin #	Name	Control Function	Type	0	1	PWD ¹
Bit 7	-		Test Mode	Reserved for Vendor	RW	Disable	Enable	0
Bit 6	-		MULT2	Multiplier Select	RW	See Table 2.		0
Bit 5	-		MULT1	Multiplier Select	RW			0
Bit 4	-		MULT0	Multiplier Select	RW			1
Bit 3	27,26		ODCLK_T/C0	Output Control	RW	Disable	Enable	1
Bit 2	24,23		ODCLK_T/C1	Output Control	RW	Disable	Enable	1
Bit 1	20,19		ODCLK_T/C2	Output Control	RW	Disable	Enable	1
Bit 0	17,16		ODCLK_T/C3	Output Control	RW	Disable	Enable	1

Disable = Output in high-impedance state
 Enable = Output is switching

SMB Table: Reserved Register

Byte 1		Pin #	Name	Control Function	Type	0	1	PWD
Bit 7	-		Reserved	Reserved	RW	-	-	0
Bit 6	-		Reserved	Reserved	RW	-	-	0
Bit 5	-		Reserved	Reserved	RW	-	-	0
Bit 4	-		Reserved	Reserved	RW	-	-	0
Bit 3	-		Reserved	Reserved	RW	-	-	0
Bit 2	-		Reserved	Reserved	RW	-	-	0
Bit 1	-		Reserved	Reserved	RW	-	-	0
Bit 0	-		Reserved	Reserved	RW	-	-	0

SMB Table: Revision & Vendor ID Register

Byte 2		Pin #	Name	Control Function	Type	0	1	PWD
Bit 7	-		RID4	Revision ID	R	-	-	X
Bit 6	-		RID3		R	-	-	X
Bit 5	-		RID2		R	-	-	X
Bit 4	-		RID1		R	-	-	X
Bit 3	-		RID0		R	-	-	X
Bit 2	-		VID2	Vendor ID	R	-	-	0
Bit 1	-		VID1		R	-	-	0
Bit 0	-		VID0		R	-	-	1

NOTES:

1. PWD = Power Up Default

PLL Multiplier

Table 2 shows the frequency multipliers in the PLL, selectable by programming the MULT0, MULT1 and MULT2 bits in the SMBus Multiplier Control register. Power up default is 4.

Table 2. PLL Multiplier Selection

Byte 0			Frequency Multiplier	Output Frequency (MHz)	
Bit 6 MULT2	Bit 5 MULT1	Bit 4 MULT0		CLK_INT/C = 100 MHz ¹	CLK_INT/C = 133 MHz ¹
0	0	0	3	300 ³	400
0	0	1	4	400 ²	533
0	1	0	5	500	667
0	1	1	6	600	800
1	0	0	8	800	-. ³
1	0	1	9/2	450	600
1	1	0	15/2	750	-. ³
1	1	1	15/4	375	500

NOTES

- 1 Output frequencies are based on nominal input frequencies of 100 MHz and 133 MHz. The PLL multipliers are also applicable to spread spectrum modulated input clocks.
- 2 Default multiplier value at power up
- 3 Outputs at these settings do not conform to the AC Output Characteristics, or are not supported.

4 Shaded areas are under development and are not yet supported

Device ID and SMBus Device Address

The device ID (SMB_A(1:0)) is part of the SMBus device address. The least significant bit of the address designates a write or read operation. Table 3 shows the addresses for four ICS9214 devices on the same SMBus.

Table 3. SMBus Device Addresses

ICS9214		Hex Address	8-bit SMBus Device Address, Including Oper.			
Device	Operation		SMB_A1	SMB_A0	WR#/RD	
0	Write	D8	11011	0	0	0
	Read	D9				1
1	Write	DA		0	1	0
	Read	DB				1
2	Write	DC		1	0	0
	Read	DD				1
3	Write	DE		1	1	0
	Read	DF				1

Operating Modes

Table 4: Operating Modes

OE	BYPASS#/ PLL	Byte 1		Byte 0				ODCLK_T/C3	ODCLK_T/C2	ODCLK_T/C1	ODCLK_T/C0
		Bit 7	Bit 3	Bit 2	Bit 1	Bit 0					
L	X	X	X	X	X	X	Z	Z	Z	Z	
H	X	1	X	X	X	X	Reserved for Vendor Test				
H	L	0	X	X	X	X	CLK_INT/C ¹				
H	H	0	0	0	0	0	Z	Z	Z	Z	
H	H	0	0	0	0	1	Z	Z	Z	CLK_INT/C	
H	H	0	0	0	1	0	Z	Z	CLK_INT/C	Z	
H	H	0	0	0	1	1	Z	Z	CLK_INT/C	CLK_INT/C	
H	H	0	0	1	0	0	Z	CLK_INT/C	Z	Z	
H	H	0	0	1	0	1	Z	CLK_INT/C	Z	CLK_INT/C	
H	H	0	0	1	1	0	Z	CLK_INT/C	CLK_INT/C	Z	
H	H	0	0	1	1	1	Z	CLK_INT/C	CLK_INT/C	CLK_INT/C	
H	H	0	1	0	0	0	CLK_INT/C	Z	Z	Z	
H	H	0	1	0	0	1	CLK_INT/C	Z	Z	CLK_INT/C	
H	H	0	1	0	1	0	CLK_INT/C	Z	CLK_INT/C	Z	
H	H	0	1	0	1	1	CLK_INT/C	Z	CLK_INT/C	CLK_INT/C	
H	H	0	1	1	0	0	CLK_INT/C	CLK_INT/C	Z	Z	
H	H	0	1	1	0	1	CLK_INT/C	CLK_INT/C	Z	CLK_INT/C	
H	H	0	1	1	1	0	CLK_INT/C	CLK_INT/C	CLK_INT/C	Z	
H	H	0 ²	1 ²	1 ²	1 ²	1 ²	CLK_INT/C	CLK_INT/C	CLK_INT/C	CLK_INT/C	

Notes

- 1 Bypass Mode
- 2 Power up default mode

Absolute Maximum Ratings

Supply Voltage	4.0 V
Logic Inputs	GND -0.5 V to V _{DD} +0.5 V
Ambient Operating Temperature	0°C to +85°C
Storage Temperature	-65°C to +150°C

Stresses above those listed under *Absolute Maximum Ratings* may cause permanent damage to the device. These ratings are stress specifications only and functional operation of the device at these or any other conditions above those listed in the operational sections of the specifications is not implied. Exposure to absolute maximum rating conditions for extended periods may affect product reliability.

DC Characteristics - Inputs

TA = 0°C to +85°C; Supply Voltage AVDD2.5, VDD2.5 = 2.5 V +/- 0.125V (unless otherwise stated)

PARAMETER	SYMBOL	CONDITIONS	MIN	TYP	MAX	UNITS
Supply Voltage	V _{DD2.5} , A _{VDD}		2.375		2.625	V
Supply Current	I _{DD2.5} , I _{VDD}				125	mA
High-level input voltage	V _{IHCLK}	CLK_INT, CLK_INC	0.6		0.95	V
Low-level input voltage	V _{ILCLK}		-0.15		0.15	V
Crossing point voltage	V _{IXCLK}		0.2		0.55	V
Difference in crossing point voltage	V _{IXCLK}				0.15	V
Input threshold voltage	V _{TH}	Singed-ended CLK_IN ¹	0.35		0.5V _{DD2.5}	V
High-level input voltage for single-ended CLK_IN	V _{IHSE}		V _{TH} + 0.3		2.625	V
Low-level input voltage for single-ended CLK_IN	V _{ILSE}		-0.15		V _{TH} - 0.3	V
High-level input voltage	V _{IH}	OE, SMB_A0, SMB_A1, BYPASS#/PLL	1.4		2.625	V
Low-level input voltage	V _{IL}		-0.15		0.8	V
High-level input voltage - SMBus	V _{IHSMB}	SMBCLK, SMBDAT	1.4		3.4652	V
Low-level input voltage - SMBus	V _{ILSMB}		-0.15		0.8	V

Notes:

- 1 When using singled-ended clock input, V_{TH} is supplied to CLK_INT_C as shown in Figure 2. Duty cycle of singled-ended CLK_IN is measured at V_{TH}
- 2 This range of SMBus input high voltages allows the 9214 to co-exist with 3.3V, 2.5V and 1.8V devices on the same SMBus.

DC Characteristics - Outputs

TA = 0°C to +85°C; Supply Voltage AVDD2.5, VDD2.5 = 2.5 V +/- 0.125V (unless otherwise stated)

PARAMETER	SYMBOL	CONDITIONS	MIN	TYP	MAX	UNITS
Power up latency	t_{PU}	Power within spec to outputs within spec			3	ms
State transition latency ¹	t_{CO}	SMBus or Mode Select transition to outputs valid and within spec			3	ms
Differential output crossing voltage	V_{OX}	Measured as shown in Fig. 3	0.9		1.1	V
Output Voltage Swing (peak-to-peak singled ended)	V_{COS}	Measured as shown in Fig. 3. Excludes over and undershoot.	300		350	mV
Absolute output low voltage	V_{OLABS}	Measured at ODCLK_T/C pins	0.85			V
Reference Voltage for swing control current	V_{ISET}	$V_{DD} = 2.3V, V_{OUT} = 1V$	0.98		1.02	V
Ratio of output low current to reference current at typical $V_{DD2.5}$	I_{OL}/I_{REF}	I_{REF} is equal to V_{ISET}/R_{RC} . Tolerance of $R_{RC} <= +/- 1\%$.	6.8	7	7.2	-
Minimum current at V_{OLABS}	I_{OLABS}	Measured at ODCLK_T/C pins with termination per Figure 3.	45		-	mA
Low-level output voltage SMBus	V_{OLSMB}	$I_{OL} = 4 \text{ mA}$	-		0.4	V
Low-level output current SMBus	I_{OLSMB}	$V_{OL} = 0.8 \text{ V}$	6		-	mA
Tristate output current	I_{OZ}	Differential clock output pins	-		50	μA

Notes:

There is no output latency or glitches if a value is written to an output register. that is the same as its current contents.

AC Characteristics-Inputs

T_A = 0°C to +85°C; Supply Voltage AVDD2.5, VDD2.5 = 2.5 V +/- 0.125V (unless otherwise stated)

PARAMETER	SYMBOL	CONDITION	MIN	TYP	MAX	UNITS
CLK_INT/CLK_INC cycle time ¹	t _{CYCLEIN}		7		11	ns
Cycle-to-Cycle Jitter	t _{cvc} -t _{cvc} ²				185	ps
Input clock duty cycle	d _{tin}	over 10,000 cycles	40		60	%
CLK_INT/CLK_INC rise and fall time	t _R , t _F	20% to 80% of input voltage	175		700	ps
Difference between input rise and fall time on same pin of a single device	t _{R-F}	20% to 80% of input voltage	-		150	ps
Spread spectrum modulation frequency	f _{INM} ³		30		33	kHz
Spread spectrum modulation index	m _{INDEX} ³	Triangular modulation			0.6	%
		Non-triangular modulation			0.54	%
Input clock slew rate	t _{sl(I)}	20% to 80% of input voltage	1		4	V/ns
Input Capacitance ⁵	C _{INCLK}	CLK_INT, CLK_INC			7	pF
Input Capacitance ⁵	C _{IN}	VI = V _{DD2.5} or GND			10	pF
CLK_INT cycle time	t _{CYCLEST}	Bypass Mode	4		40	ns
SMBus clock frequency	f _{SMB}		10		100	kHz

Notes:

1. Measured at (VIH(nom) - VIL(nom))/2 and is the absolute value of the worst case deviation.
2. Measured at crossing points for differential clock input or at VTH for single-ended clock input
3. If input modulation is used. Input modulation is not necessary.
4. The amount of allowed spreading for non-triangular modulation is determined by the induced downstream tracking skew.
5. Capacitance measured at f = 1 MHz, DC bias = 0.9V, VAC <100mV.

AC Characteristics-Outputs

$T_A = 0^\circ\text{C}$ to $+85^\circ\text{C}$; Supply Voltage AVDD2.5, VDD2.5 = 2.5 V +/- 0.125V (unless otherwise stated)

PARAMETER ¹	SYMBOL	CONDITION	MIN	TYP	MAX	UNITS
Output clock cycle time	t_{CYCLE}		1.5		2.5	ns
Short term jitter (over 1 to 6 clock cycles)	t_{J}^2	f = 400 to 635 MHz	-		40	ps
		f = 635 to 800 MHz	-		30	ps
Output Phase error when tracking SSC	$t_{\text{ERR,SSC}}$		-100		100	ps
Change in skew	t_{SKEW}^3	$T_A = 0^\circ\text{C}$ to $+85^\circ\text{C}$, AVDD2.5, VDD2.5 = 2.5 V +/- 0.125V	-		15	ps
Long term average output duty cycle	DC		45		55	%
Cycle-to-cycle duty cycle error	t_{DCERR}	f = 400 to 635 MHz	-		40	ps
		f = 635 to 800 MHz	-		30	ps
Output rise and fall times	$t_{\text{R}}, t_{\text{F}}$	20% to 80% of output voltage	100		300	ps
Difference between output rise and fall time on same pin of a single device	$t_{\text{R-F}}$	20% to 80% of output voltage, f = 400 to 800 MHz	-		100	ps
Dynamic output impedance	Z_{OUT}^4	$V_{\text{OL}} = 0.9\text{ V}$	1000		-	Ω

Notes:

1. Max and min output clock cycle times are based on nominal output frequencies of 400 and 667 MHz respectively. For spread spectrum modulated input clocks, the output clocks track the input modulation.
2. Output short-term jitter is the absolute value for the worst case deviation and is defined in the Jitter section.
3. t_{SKEW} is the timing difference between any two of the four differential clocks and is measured at common mode voltage.
4. Z_{out} is defined at the output pins.
5. Guaranteed by design and characterization, not 100% tested in production

Thermal Characteristics

Parameter	Symbol	Conditions	Min.	Typ.	Max.	Units
Thermal Resistance Junction to Ambient	θ_{JA}	Still air		120		$^\circ\text{C}/\text{W}$
	θ_{JA}	1 m/s air flow		95		$^\circ\text{C}/\text{W}$
	θ_{JA}	3 m/s air flow		80		$^\circ\text{C}/\text{W}$
Thermal Resistance Junction to Case	θ_{JC}			20		$^\circ\text{C}/\text{W}$
Thermal Resistance Junction to Top of Case	Ψ_{JT}	Still Air		4.5		$^\circ\text{C}/\text{W}$
Maximum Case Temp					120	$^\circ\text{C}$

Clock Output Drivers

Figure 2 shows the clock driver equivalent circuit. The differential driver produces a specified voltage swing on the channel by switching the currents going into ODCLK_T and ODCLK_C. The external resistor R_{RC} at the IREFY pin sets the maximum current. The minimum current is zero.

The voltage at the IREFY pin, V_{IREFY} , is by design equal to 1 V nominally, and the driver current is seven times the current flowing through R_{RC} . So, the output low current can be estimated as $I_{OL} = 7 / R_{RC}$.

The driver output characteristics are defined together with the external resistors, R_1 , R_2 , and R_3 . The output clock signals are specified at the measurement points indicated in Figure 2. Table 5 shows example values for the resistors.

R_1 , R_2 , and R_3 and the clock driver output impedance, Z_{OUT} , must match the impedance of the channel, Z_{CH} , to minimize secondary reflections. Z_{OUT} is specified as 1000 Ohms, minimum to accomplish this. The effective impedance can be estimated by:

$$(1000R_1/(1000+R_1)+R_2) \parallel R_3/(1000R_1/(1000+R_1)+R_2+R_3)$$

Pull-up resistor R_T terminates the transmission line at the load to minimize clock signal reflection signal reflections. Table 5 shows the resistor values for establishing an effective source termination impedance of 49.2 Ohms to match a 50 Ohm channel. The termination voltages are 2.5 V for V_{TS} and 1.2 V for V_T . The resistor values $R_1 = 38.3$ Ohms, $R_2 = 19.1$ Ohms, $R_3 = 54.9$ Ohms and $R_{RC} = 200$ Ohms can be used to match a 28 Ohm channel.

Table 5. Example Resistor Values and Termination Voltages for a 50 Ohm Channel¹

Symbol	Parameter	Value	Tolerance	Unit
R_1	Termination resistor	39.2	+/- 1%	Ω
R_2	Termination resistor	66.5	+/- 1%	Ω
R_3	Termination resistor	93.1	+/- 1%	Ω
R_T	Termination resistor	49.9	+/- 1%	Ω
R_{RC}	Swing control resistor	200	+/- 1%	Ω
V_{TS}	Source termination voltage	2.5	+/-5%	V
V_T	Termination voltage	1.2	+/-5%	V

Notes:

- 1 A different set of resistors is used in Figure 2 when testing for maximum output current of the clock driver (I_{OLABS}). These resistors are: $R_1 = 34\Omega$, $R_2 = 31.8\Omega$, $R_3 = 48.7\Omega$, $R_T=28\Omega$, $R_{RC} = 147\Omega$

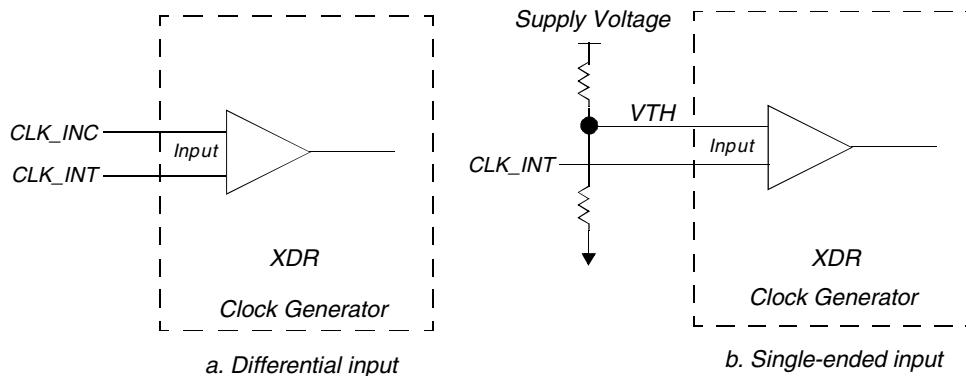

Figure 1. Differential and single-ended reference clock inputs

Input Clock Signal

The ICS9214 receives either a differential or single-ended reference clock (CLK_INT/C). When the reference input clock is from a differential clock source, it must meet the voltage levels and timing requirements listed in the **DC Characteristics – Inputs** and **AC Characteristics – Inputs** tables.

For a singled-ended clock input, an external voltage divider and a supply voltage, as shown in Figure 2, provide a reference voltage V_{TH} at the CLK_INC pin to determine the proper switching point for CLK_INT. The range of V_{TH} is specified in the **DC Characteristics – Inputs** table.

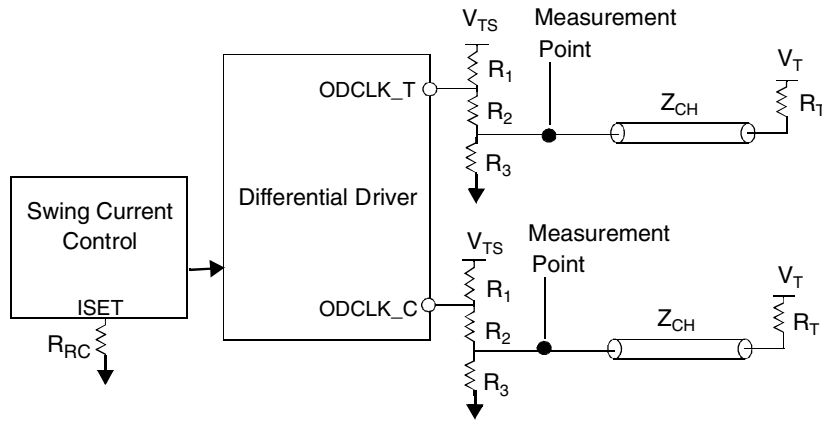

Figure 2. Example System Clock Driver Equivalent Circuit

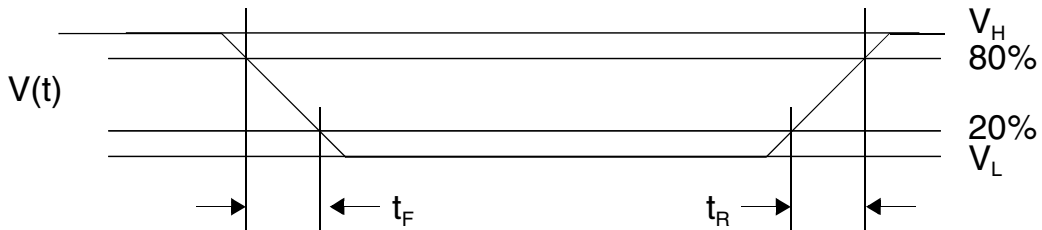

Figure 3. Input and Output Voltage Waveforms

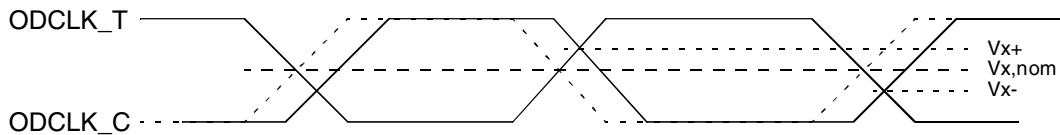

Figure 4. Crossing-point Voltage

Power Sequencing

Supply voltages for the ICS9214 must be applied before, or at the same time and external input and output signals.

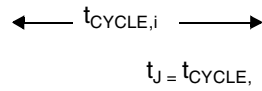

Figure 5. Cycle-to-cycle Jitter

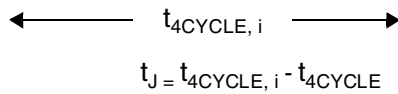

Figure 6. Short-term Jitter

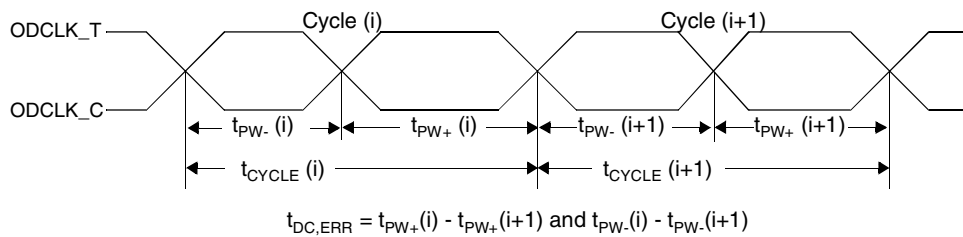

Figure 7. Cycle-to-cycle Duty Cycle Error

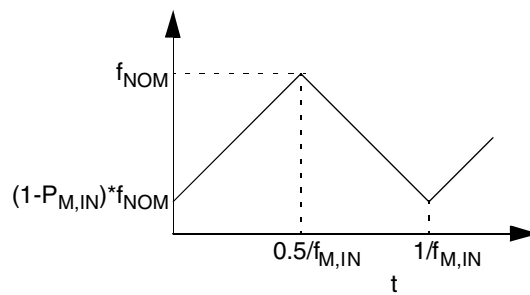

Figure 8. Input frequency Modulation

Phase Noise

The 9214 meets the single side band phase noise spectral purity for offset frequencies between 1 MHz and 100 MHz as described by the equation:

$$10\log[1+(50 \times 106/f)^{2.4}] -138 \text{ dBc/Hz}$$

This equation is shown in **Figure 9. Phase Noise Plot**

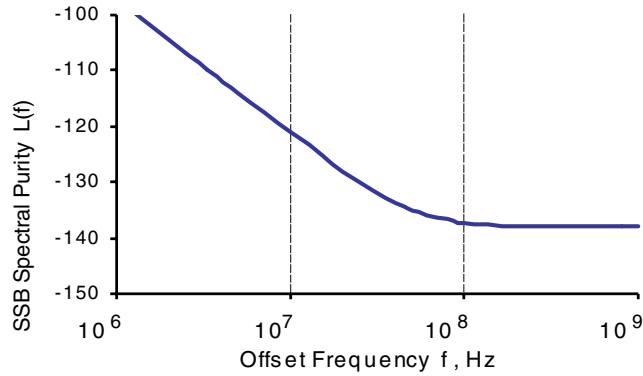
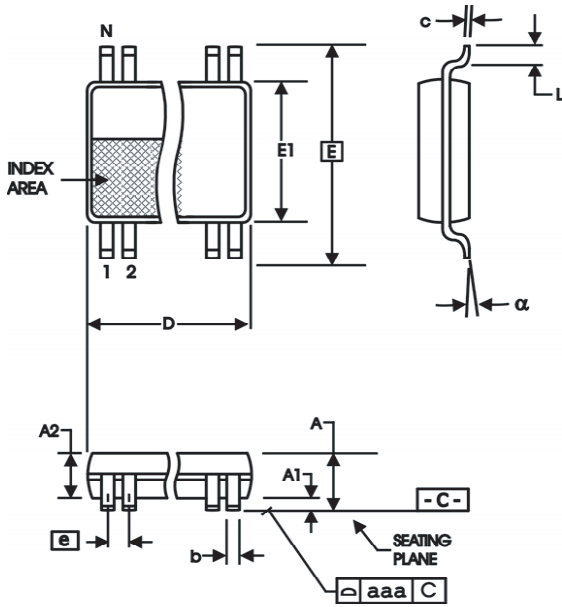

Figure 9 : Phase Noise Plot

Sample points are for this equation are shown in **Table 6. Phase Noise Data Points**

Offset Frequency (MHz)	1	5	10	15	20	40	80	100
SSB Spectral Purity (dbc/Hz)	-97	-114	-121	-125.2	-128	-133.7	-136.8	-137.3

Table 6 : Phase Noise Data Points



4.40 mm. Body, 0.65 mm. Pitch TSSOP
(173 mil) (25.6 mil)

SYMBOL	In Millimeters COMMON DIMENSIONS		In Inches COMMON DIMENSIONS	
	MIN	MAX	MIN	MAX
A	--	1.20	--	.047
A1	0.05	0.15	.002	.006
A2	0.80	1.05	.032	.041
b	0.19	0.30	.007	.012
c	0.09	0.20	.0035	.008
D	SEE VARIATIONS		SEE VARIATIONS	
E	6.40 BASIC		0.252 BASIC	
E1	4.30	4.50	.169	.177
e	0.65 BASIC		0.0256 BASIC	
L	0.45	0.75	.018	.030
N	SEE VARIATIONS		SEE VARIATIONS	
alpha	0°	8°	0°	8°
aaa	--	0.10	--	.004

VARIATIONS

N	D mm.		D (inch)	
	MIN	MAX	MIN	MAX
28	9.60	9.80	.378	.386

Reference Doc.: JEDEC Publication 95, MO-153

10-0035

Ordering Information

ICS9214yG LF-T

Example:

ICS XXXX y G LF-T

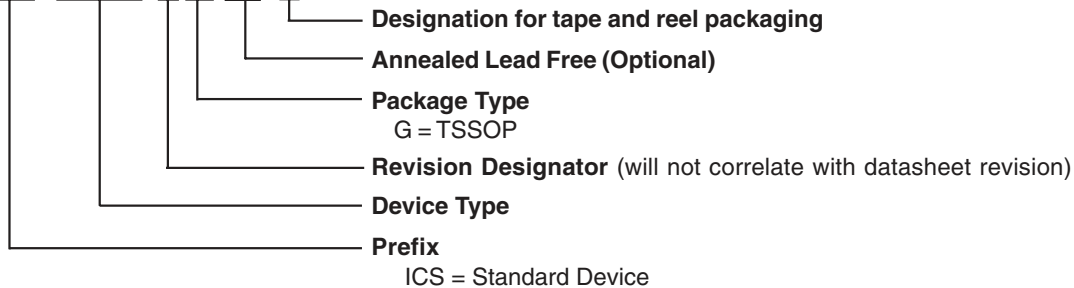

Revision History

Rev.	Issue Date	Description	Page #
0.1	3/30/2005	Updated SMBus table Byte 2, Bit 3 from:0 to:1.	4-5,15
		Updated PLL Multiplier Selection Table, from: Byte 1 to: Byte 0, and Bit 2,1,0, to: Bit 6,5,4.	
		Updated Ordering Information from "Lead Free" to "Annealed Lead Free"	
A	4/6/2005	Added Phase noise spec Removed unsupported speeds from PLL Multiplier Selection, Changed minimum output raise, fall times from 140ps to 100 ps Compliant with Rev 0.81 of XCG spec.	Various
B	4/22/2005	1. Changed write address from D2 to a valid address (D8) 2. Changed read address from D3 to a valid address (D9)	3
C	11/11/2005	Added the 15/4 entry in the gear table to the list of supported frequencies	5
D	4/7/2006	Added Thermal Characteristics Table.	10
E	11/17/2006	Updated Pin Description.	2
F	11/5/2007	Updated to extended temperature range	-
G	5/2/2008	Updated SMBus Byte 1.	4

IMPORTANT NOTICE AND DISCLAIMER

RENESAS ELECTRONICS CORPORATION AND ITS SUBSIDIARIES (“RENESAS”) PROVIDES TECHNICAL SPECIFICATIONS AND RELIABILITY DATA (INCLUDING DATASHEETS), DESIGN RESOURCES (INCLUDING REFERENCE DESIGNS), APPLICATION OR OTHER DESIGN ADVICE, WEB TOOLS, SAFETY INFORMATION, AND OTHER RESOURCES “AS IS” AND WITH ALL FAULTS, AND DISCLAIMS ALL WARRANTIES, EXPRESS OR IMPLIED, INCLUDING, WITHOUT LIMITATION, ANY IMPLIED WARRANTIES OF MERCHANTABILITY, FITNESS FOR A PARTICULAR PURPOSE, OR NON-INFRINGEMENT OF THIRD PARTY INTELLECTUAL PROPERTY RIGHTS.

These resources are intended for developers skilled in the art designing with Renesas products. You are solely responsible for (1) selecting the appropriate products for your application, (2) designing, validating, and testing your application, and (3) ensuring your application meets applicable standards, and any other safety, security, or other requirements. These resources are subject to change without notice. Renesas grants you permission to use these resources only for development of an application that uses Renesas products. Other reproduction or use of these resources is strictly prohibited. No license is granted to any other Renesas intellectual property or to any third party intellectual property. Renesas disclaims responsibility for, and you will fully indemnify Renesas and its representatives against, any claims, damages, costs, losses, or liabilities arising out of your use of these resources. Renesas' products are provided only subject to Renesas' Terms and Conditions of Sale or other applicable terms agreed to in writing. No use of any Renesas resources expands or otherwise alters any applicable warranties or warranty disclaimers for these products.

(Disclaimer Rev.1.0 Mar 2020)

Corporate Headquarters

TOYOSU FORESIA, 3-2-24 Toyosu,
Koto-ku, Tokyo 135-0061, Japan
www.renesas.com

Contact Information

For further information on a product, technology, the most up-to-date version of a document, or your nearest sales office, please visit:
www.renesas.com/contact/

Trademarks

Renesas and the Renesas logo are trademarks of Renesas Electronics Corporation. All trademarks and registered trademarks are the property of their respective owners.