

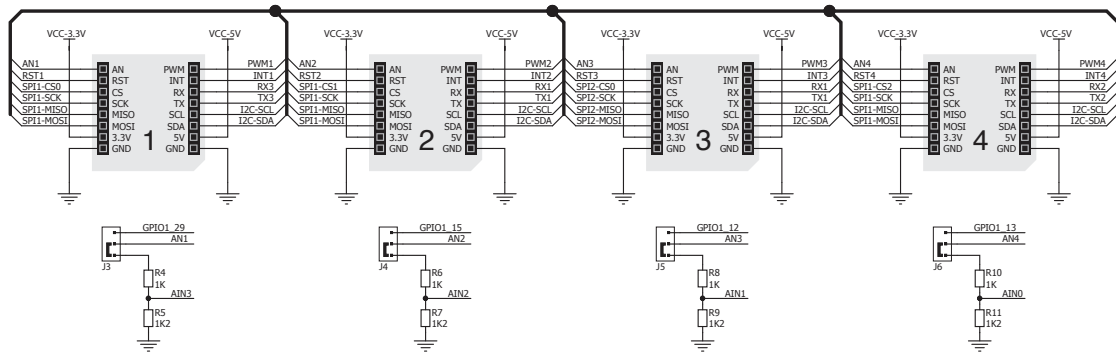

# mikroBUS™ Cape

ver.  
100

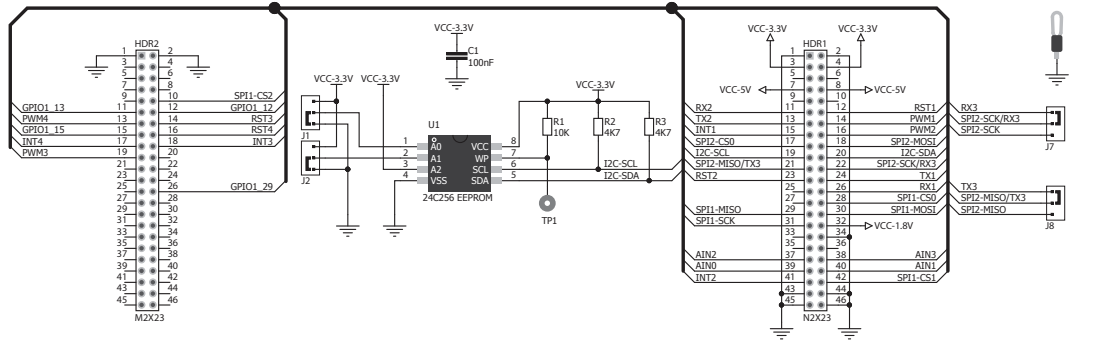



- Legend
- mm
  - mils

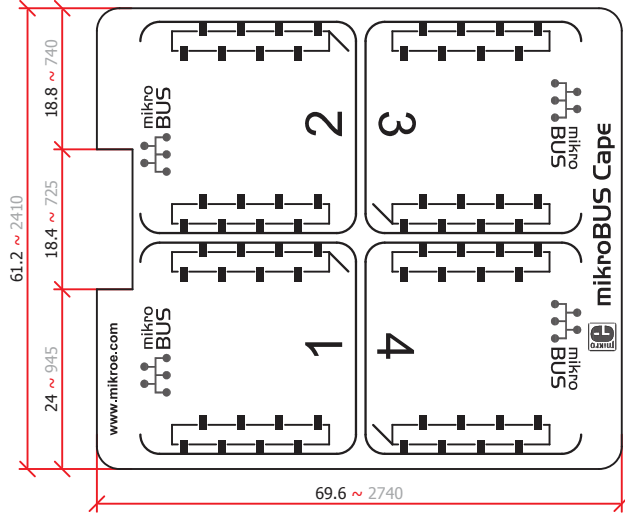

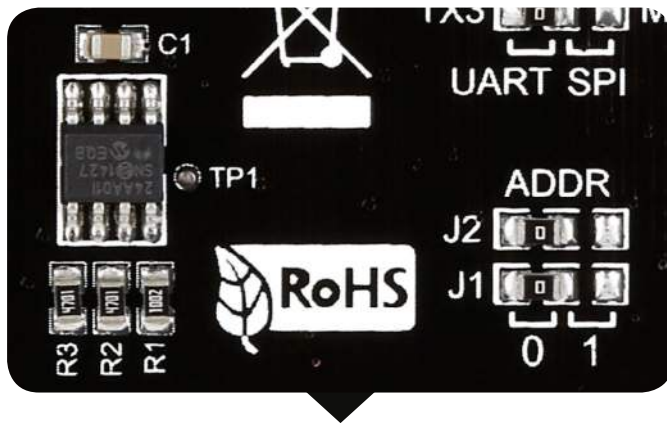

Note

The BeagleBone click™ shield has an EEPROM module for storing pin configuration data. Initially the shield is configured with a blank EEPROM. The default address for the EEPROM is 0x54. You can change it to addresses 0x50 - 0x57 with the selection of the two address jumpers. They are Labeled A0 and A1. To write to EEPROM, use the onboard TP1 pin [which needs to be connected to GND].